

PI3EQX16908GL

16Gbps 8-Channel ReDriver with Linear Equalization

Features

- 2.5 to 16 Gbps serial link with linear equalizer
- Supports PCIe4/ UPI protocols
- Supporting 8 differential channels
- Independent channel configuration of receiver equalization, output swing and flat gain
- Transparent to link training, Idle, OOB
- I2C selectable device programming
- 1-bit selectable address bit for I2C
- Supply Voltage: 3.3V±0.3V
- Industrial Temperature Range: -40°C to 85°C
- Totally Lead-Free & Fully RoHS Compliant (Notes 1 & 2)
- Halogen and Antimony Free. "Green" Device (Note 3)
- For automotive applications requiring specific change control (i.e. parts qualified to AEC-Q100/101/200, PPAP capable, and manufactured in IATF 16949 certified facilities), please [contact us](https://www.diodes.com/quality/product-definitions/) or your local Diodes representative.
<https://www.diodes.com/quality/product-definitions/>
- Packaging (Pb-free & Green):
 - 72-contact TQFN (5mm x11mm)

Description

Diodes' PI3EQX16908GL is a multi-data rate, 8 differential channels ReDriver™. The device provides programmable linear equalization, output swing and flat gain, by I2C Control, to optimize performance over a variety of physical mediums by reducing Inter-symbol interference.

PI3EQX16908GL supports eight 100-Ohm Differential CML data I/O's and extends the signals across other distant data pathways on the user's platform.

The integrated equalization circuitry provides flexibility with signal integrity of the signal before the ReDriver, whereas the integrated linear amplifier/buffer circuitry provides flexibility with signal integrity of the signal after the ReDriver.

Applications

- Networking
- Enterprise
- Server
- Storage

Block Diagram

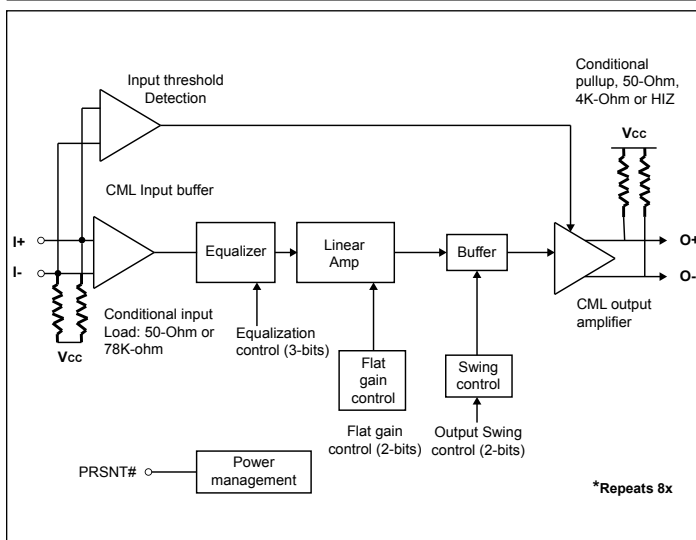

Ordering Information

Part Number	Package	Description
PI3EQX16908GLZLEX	ZL	72-Contact (TQFN) W-QFN50110-72

Notes:

1. No purposely added lead. Fully EU Directive 2002/95/EC (RoHS), 2011/65/EU (RoHS 2) & 2015/863/EU (RoHS 3) compliant.
2. See <https://www.diodes.com/quality/lead-free/> for more information about Diodes Incorporated's definitions of Halogen- and Antimony-free, "Green" and Lead-free.
3. Halogen- and Antimony-free "Green" products are defined as those which contain <900ppm bromine, <900ppm chlorine (<1500ppm total Br + Cl) and <1000ppm antimony compounds.
4. E = Pb-free and Green
5. X suffix = Tape/Reel