

used for: D-SUB HD FILTER

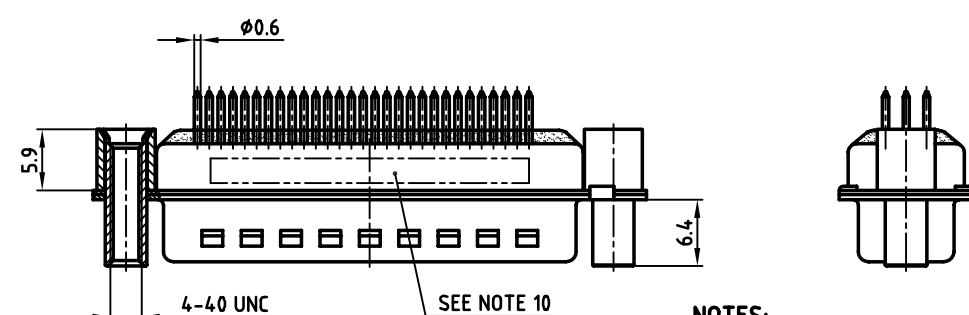
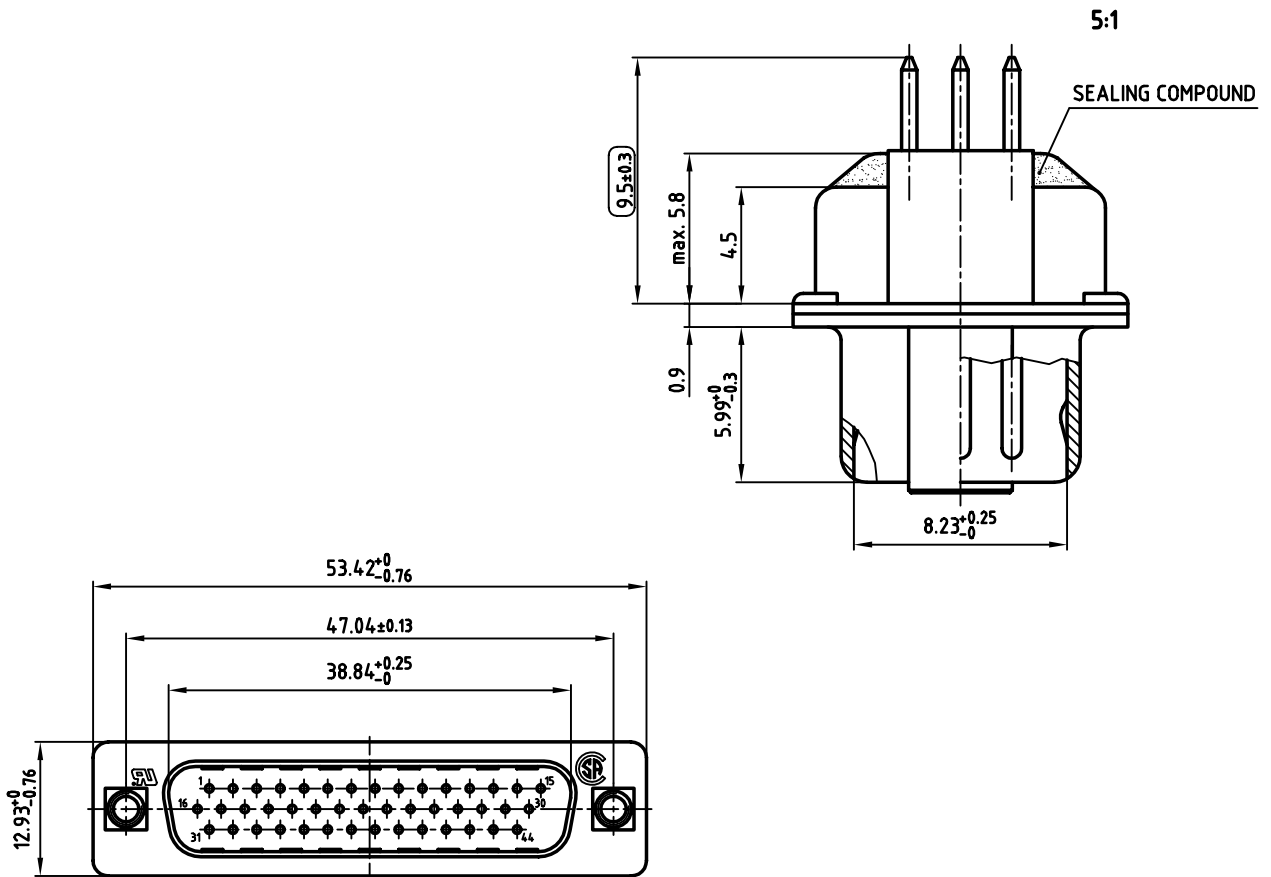

- NOTES:**
- METALSHELLS: STEEL; min. 320µ" TIN
 - INSULATORS: PBT GF UL 94 V-0, BLACK
 - CONTACTS: COPPER ALLOY
PLATING: 8µ" HARD GOLD OVER min. 50µ" NICKEL
 - THREADED REAR SPACER / FRONT THREADED LOCK: COPPER ALLOY; min. 200µ" TIN over 80µ" NICKEL
 - SLEEVE: COPPER ALLOY; min. 200µ" TIN over 80µ" NICKEL
 - P.C.B. HOLE DRILLINGS ON DRAWING NO.: 16V11H5B
 - CAPACITANCE: SEE TABLE
 - DIELECTRIC WITHSTANDING VOLTAGE: 300V DC
 - MAXIMUM TORQUE VALUE FOR THREAD: 6" LBS
 - CONNECTOR IS PART MARKED: PART-NO. CONEC Y/WW
 - = CHECK DIMENSION

CAPACITANCE	PART NO.
180pF ±20%	241A27700X
370pF ±20%	241A16800X
830pF ±20%	241A16840X

APPROVAL * FREIGABE * DEBLOCAGE * AUTORIZACION * APPROVAL

CUSTOMER APPROVAL DATE:

NAME: TITLE:

COMPANY NAME:

APPROVAL * FREIGABE * DEBLOCAGE * AUTORIZACION * APPROVAL

THIS DRAWING MAY NOT BE COPIED OR REPRODUCED IN ANY WAY, AND MAY NOT BE PASSED ON TO A THIRD PARTY, WITHOUT WRITTEN PERMISSION. OWNERSHIP AND COPYRIGHT OF CONEC GmbH DO NOT ALTER CAD DRAWING BY HAND

tolerance		scale:	2:1 (5:1)
	dim. in mm	material:	SEE NOTES
2003	date	name	title:
drawn	23.09.	Lehmenkühler	D-SUB HD FILTER MALE
appd.	24.09.	Mickenbecker	44pos. SOLDER PIN STRAIGHT
norm	DIN 41652		threaded rear spacer and front threaded lock
d-old			dwg no: AutoCAD 2000
		24K1A461	
		part no: SEE TABLE	DIN-A 3 sh:1/1
rev.	description	date	name