

## 3-Channel Low Dropout RGB LED Driver

### General Description

The RT9301 is a 3-Channel current source driver for RGB LED. It is easy to be designed in applications that need mixing RGB light source for multi-color output.

The RT9301 also provide users with great flexibility and device performance. It uses externals resistor to set the bias current for three LEDs, which are matched to 5%(max.). Users can adjust the output current from 2mA to 50mA by setting the ISET resistor.

The RT9301 features very low dropout and under voltage lockout protection. It is available in a space-saving TSOT-23-8 and WDFN-8L 3x3 packages.

### Ordering Information

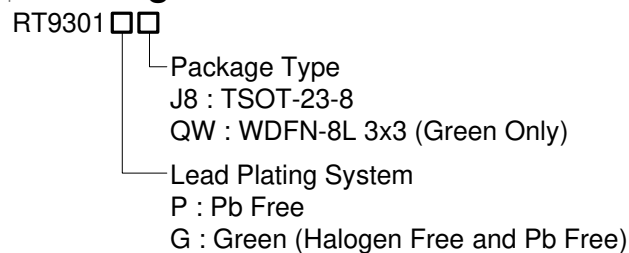

Note :

- WDFN-8L 3x3 is in W-Type
- Richtek products are :
  - RoHS compliant and compatible with the current requirements of IPC/JEDEC J-STD-020.
  - Suitable for use in SnPb or Pb-free soldering processes.

### Marking Information

For marking information, contact our sales representative directly or through a Richtek distributor located in your area.

### Features

- Input Voltage Range : 2.8V to 5.5V
- Low 60/45mV Dropout at 20/15mA
- Individual Current Setting by External Resistor
- Individual On/Off Control by Baseband MPU
- Up to 50mA LED Bias Current
- Simple LED Brightness Control
- 5%(max.) LED Current Matching
- Low 0.1uA Shutdown Current
- UVLO Protection
- RoHS Compliant and 100% Lead (Pb)-Free

### Applications

- Mobile phone, Smart Phone Multi-color LED Backlight
- Camera Flash White LED
- LCD Display Modules
- Keypad Backlight

### Pin Configurations

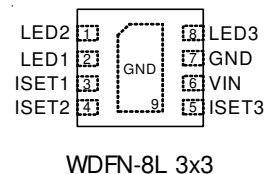
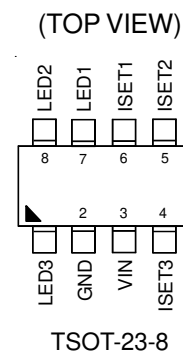

## Typical Application Circuit

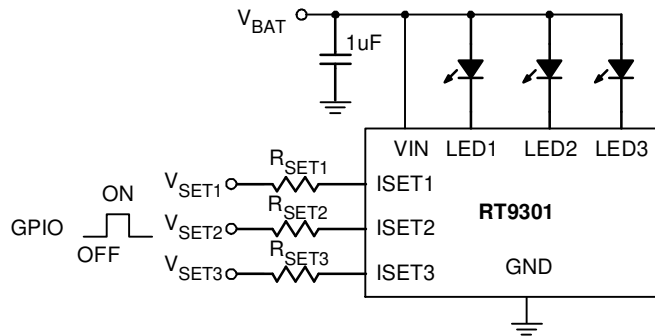

Figure 1. Application circuit for RGB LED

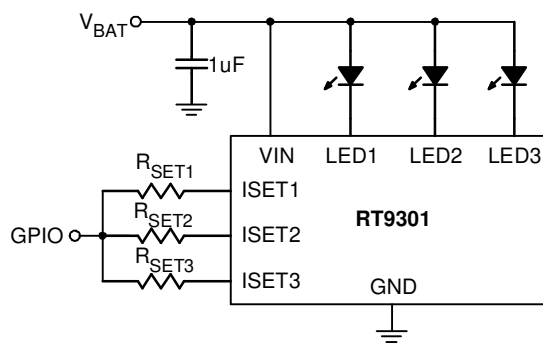

Figure 2. Application Circuit for Backlight

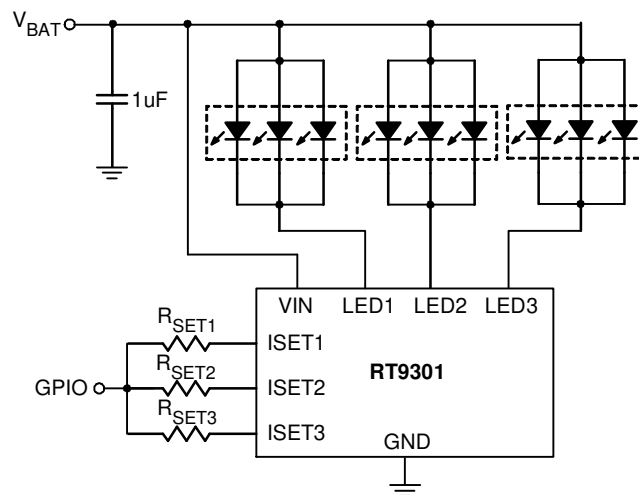
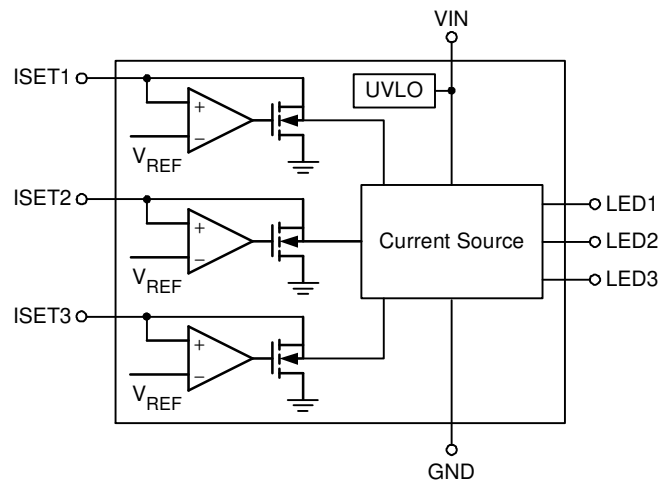

Figure 3. Application Circuit for Keypad

$$I_{LED1 \sim 3} = 800 \times I_{SET1 \sim 3} = 800 \times \frac{V_{SET1 \sim 3} - 0.9V}{R_{SET1 \sim 3}}$$

GPIO (V)	I <sub>LED</sub> (mA)	R <sub>SET</sub> (kΩ)	Nearest Standard Values for R <sub>SET</sub> (kΩ)
1.8	15	48	47.5
	20	36	36
2.8	15	101	100
	20	76	75

**Function Block Diagram**



**Functional Pin Description**

Pin No.		Pin Name	Pin Function
RT9301□J8	RT9301GQW		
1	8	LED3	RGB or White LED cathode connection pin. 2mA to 50mA Current flows into LED. Floating or connection to ground is used to disable this pin.
2	7, Exposed Pad (9)	GND	Ground Pin. The exposed pad must be soldered to a large PCB and connected to GND for maximum power dissipation.
3	6	VIN	Power Input Pin.
4	5	ISET3	Current setting for LED3. Connect to GND if not use.
5	4	ISET2	Current setting for LED2. Connect to GND if not use.
6	3	ISET1	Current setting for LED1. Connect to GND if not use.
7	2	LED1	RGB or White LED cathode connection pin. 2mA to 50mA Current flows into LED. Floating or connection to ground is used to disable this pin.
8	1	LED2	RGB or White LED cathode connection pin. 2mA to 50mA Current flows into LED. Floating or connection to ground is used to disable this pin.

## Absolute Maximum Ratings (Note 1)

Supply Input Voltage	-----	-0.3V to 6V
LED1,2,3 Pin Voltage	-----	-0.3V to $V_{IN} + 0.3V$
Other I/O Pin Voltages	-----	-0.3V to 6V
Power Dissipation, $P_D$ @ $T_A = 25^\circ C$		
TSOT-23-8	-----	0.382W
WDFN-8L 3x3	-----	0.926W
Package Thermal Resistance (Note 2)		
TSOT-23-8, $\theta_{JA}$	-----	262°C/W
WDFN-8L 3x3, $\theta_{JA}$	-----	108°C/W
WDFN-8L 3x3, $\theta_{JC}$	-----	8.2°C/W
Lead Temperature (Soldering, 10 sec.)	-----	260°C
Junction Temperature	-----	150°C
Storage Temperature Range	-----	-65°C to 150°C
ESD Susceptibility (Note 3)		
HBM (Human Body Mode)	-----	2kV
MM (Machine Mode)	-----	200V

## Recommended Operating Conditions (Note 4)

Junction Temperature Range	-----	-40°C to 125°C
Ambient Temperature Range	-----	-40°C to 85°C

## Electrical Characteristics

( $V_{IN} = 3.6V$ ,  $T_A = 25^\circ C$ , Unless Otherwise specification)

Parameter	Symbol	Test Conditions	Min	Typ	Max	Unit
Input Supply Voltage	$V_{IN}$		2.8	--	5.5	V
UVLO Threshold	$V_{UVLO\_L}$	Falling	2	2.2	2.4	V
UVLO Hysteresis			--	100	--	mV
Dropout Voltage	$V_{LED}$	90% of $I_{LED} = 16mA$	--	40	120	mV
ISET Reference Voltage			0.8	0.9	1	V
Quiescent Current	$I_Q$	LED Open, $I_{SET} = 20 \mu A$	--	0.5	1	mA
$I_{LED}$ Matching		$I_{LED} = 16mA$	-5	--	+5	%
$I_{LED}$ Accuracy	$I_{LED}$	$I_{LED} = 16mA$	-5	--	+5	%
Shutdown current		All $V_{SET1\sim3} < 0.25V$	--	0.1	2	$\mu A$
$V_{SET}$ Enable Threshold	$V_{SET}$	$V_{SET}$ connect $R_{SET} = 47k\Omega$ to $I_{SET}$	1.3	--	--	V
$V_{SET}$ Disable Threshold	$V_{IL}$	$V_{SET}$ connect $R_{SET} = 47k\Omega$ to $I_{SET}$	--	--	0.25	V

**Note 1.** Stresses listed as the above "Absolute Maximum Ratings" may cause permanent damage to the device. These are for stress ratings. Functional operation of the device at these or any other conditions beyond those indicated in the operational sections of the specifications is not implied. Exposure to absolute maximum rating conditions for extended periods may remain possibility to affect device reliability.

**Note 2.**  $\theta_{JA}$  is measured in the natural convection at  $T_A = 25^\circ C$  on a low effective single layer thermal conductivity test board of JEDEC 51-3 thermal measurement standard. The case point of  $\theta_{JC}$  is on the expose pad for the WDFN package.

**Note 3.** Devices are ESD sensitive. Handling precaution is recommended.

**Note 4.** The device is not guaranteed to function outside its operating conditions.

**Typical Operating Characteristics**

**LED Current vs. Input Voltage**

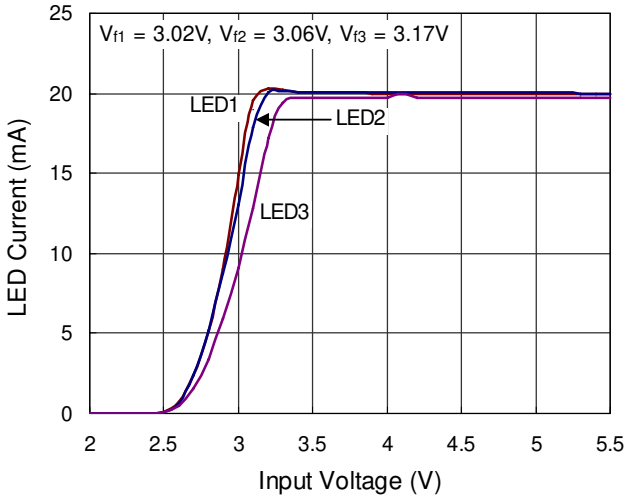

**LED Current vs.  $V_{SET}$**

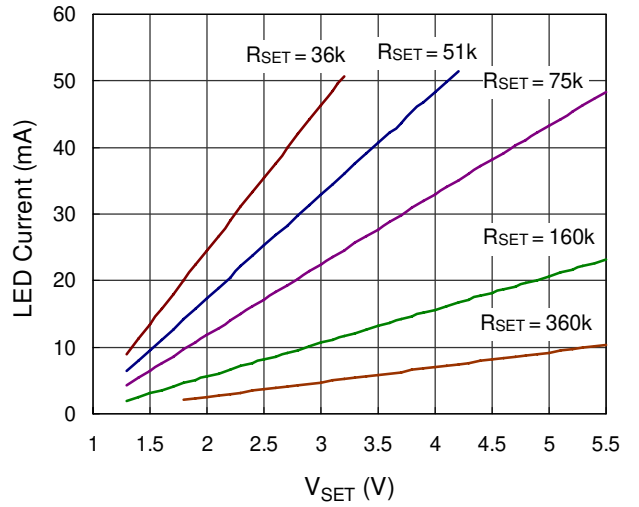

**LED Current vs. Temperature**

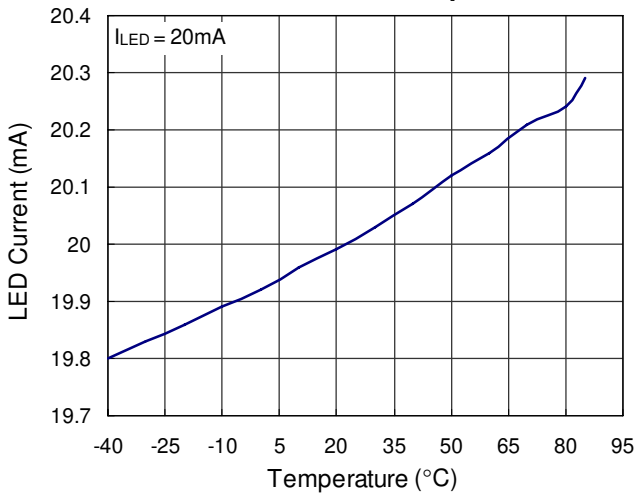

**Dimming Operation**

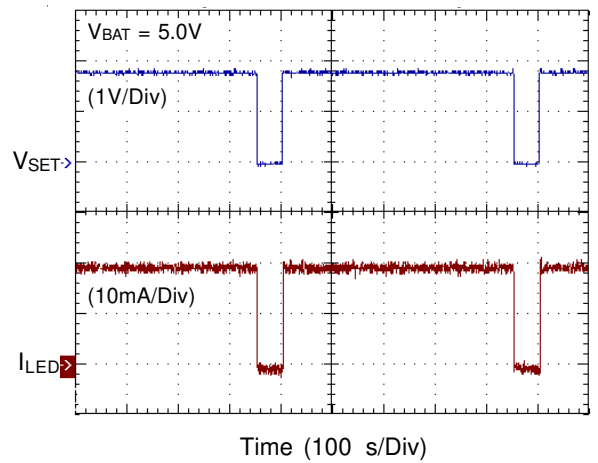

**Enable & Shutdown Response**

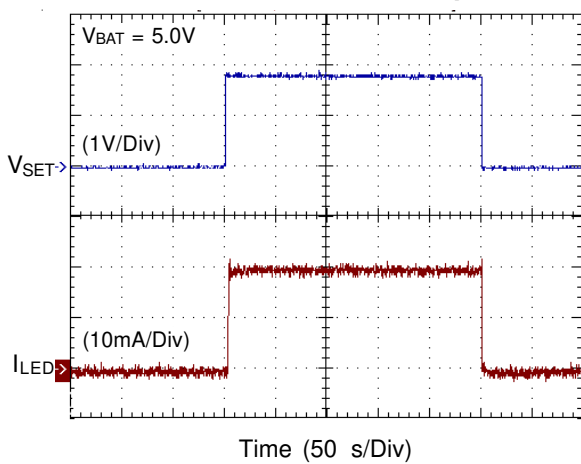

**Line Transient Response**

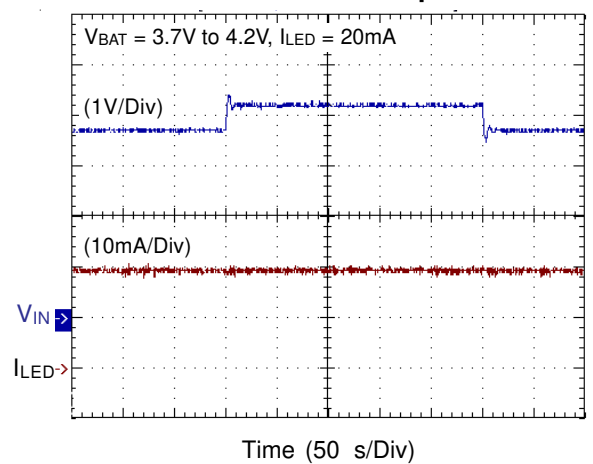

## Applications Information

The RT9301 is a 3-Channel current source driver for RGB LED or white LEDs. The output current can be controlled from 2mA to 50mA by adjusting the setting current from external. It is easy to support a multi-color RGB LED.

### Input UVLO

The input operating voltage range of the RT9301 is 2.8V to 5.5V. An input capacitor at the VIN pin could reduce ripple voltage. It is recommended to use a ceramic 1uF or larger capacitance as the input capacitor. This IC provides an under voltage lockout (UVLO) function to prevent it from unstable issue when startup. The UVLO threshold of input falling voltage is set at 2.1V typically with a hysteresis 0.1V.

### Output Current Setting

The LED current is setting by the current of ISET pin. The LED current of the three channels (LED1, LED2, LED3) could be set from the ISET (ISET1, ISET2, ISET3) pins individually. The typical application circuit shows as Figure 1.

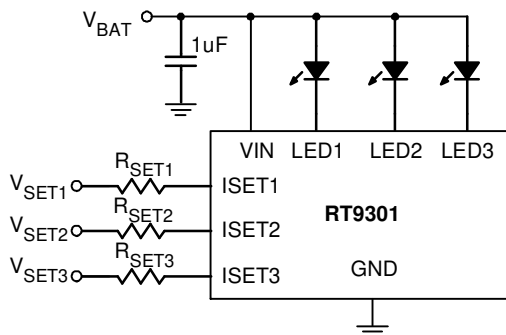

Figure 1. Typical Application Circuit

The LED current can be controlled from an external voltage ( $V_{SET}$ ) and a resistor ( $R_{SET}$ ) between  $V_{SET}$  and ISET pin. The voltage range of  $V_{SET}$  is from 1.3V to 5.5V. The internal reference voltage at ISET pin is 0.9V typically. LED current is set as 800 times the current flowing into ISET pin. Therefore, the LED current can be calculated as the following equation.

$$I_{LED1 \sim 3} = 800 \times I_{SET1 \sim 3} = 800 \times \frac{V_{SET1 \sim 3} - 0.9V}{R_{SET1 \sim 3}}$$

For example,  $R_{SET1} = 45k\Omega$  and  $V_{SET1} = 1.8V$ , the current of LED1 is equal to 16mA.

The LED current of each channel can be controlled from 2mA to 50mA. It is easy to obtain a multi-color output by changing the current of ISET1, ISET2, and ISET3 respectively.

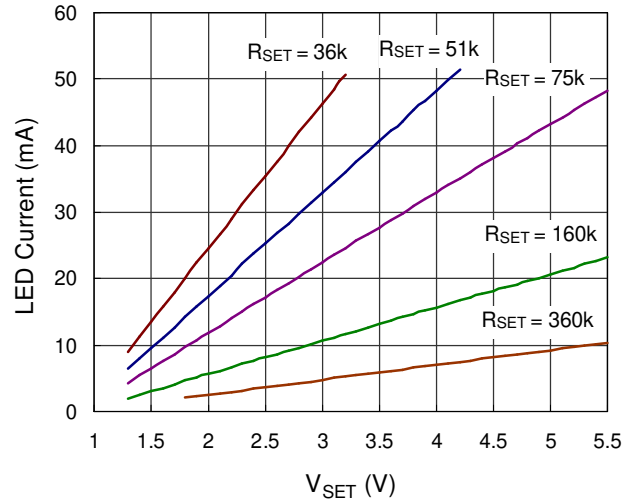

Figure 2. LED Current Setting

Figure 2 shows the characteristics of  $I_{LED}$  vs.  $V_{SET}$ . If the  $R_{SET}$  is selected, the LED current could be controlled from  $V_{SET}$ . The voltage of  $V_{SET}$  must be higher than 1.3V to enable the LED. For low LED current application, it is recommended to use a higher resistance on  $R_{SET}$  (for example:  $R_{SET} = 360k\Omega$ ).

To disable the LED current, the ISET pin should be connected to ground or floating. For one LED or two LEDs application, the unused ISET pin should be connected to GND. In addition, don't short  $V_{SETx}$  to ISETx pin.

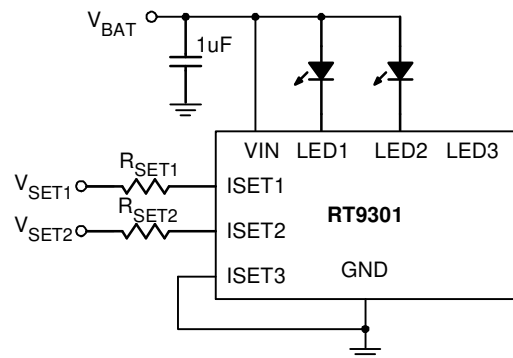

Figure 3. Application Circuit for Two LEDs

**GPIO Control**

Figure 4 shows an application circuit for backlight with GPIO. The three setting resistors are connected to GPIO. The LED current can be controlled by GPIO directly. The RT9301 provides low dropout voltage and 5% maximum current matching. It also allows dimming control frequency up to 10kHz.

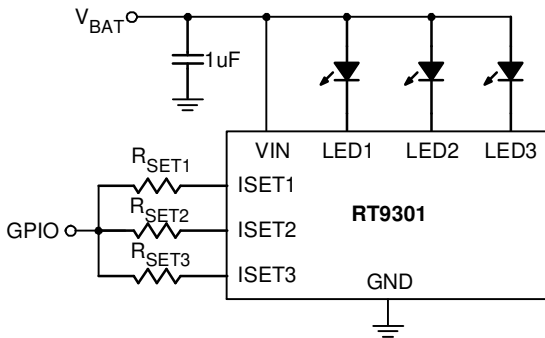

Figure 4. Application Circuit for Backlight with GPIO

The LED current can be set at different value with proper setting resistor. For typical application of GPIO 1.8V/2.8V and LED current 15mA/20mA, the recommended current setting resistors are showed as below table.

**Table 1. R<sub>SET</sub> Value Selection**

GPIO (V)	I <sub>LED</sub> (mA)	R <sub>SET</sub> (kΩ)	Nearest Standard Values for R <sub>SET</sub> (kΩ)
1.8	15	48	47.5
	20	36	36
2.8	15	101	100
	20	76	75

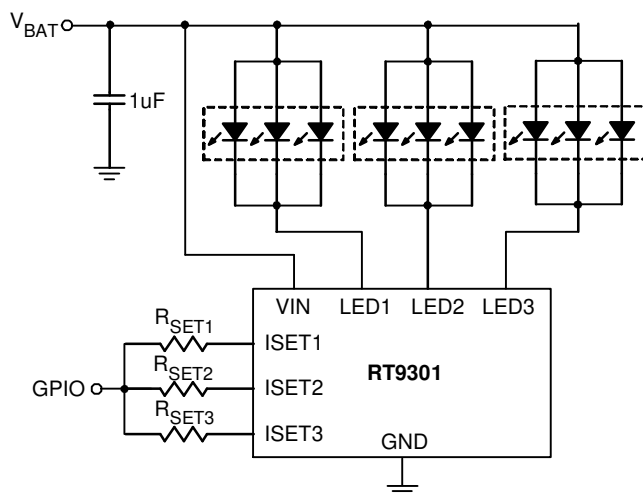

Figure 5. Application Circuit for Keypad Backlight

Figure 5 shows another application circuit for keypad backlight with GPIO. There are 9 LEDs operation in parallel. A battery or a regulated power source drives the LEDs. Each channel supports three LEDs. The LED brightness adjustment can be set with proper setting resistor for each channel and be controlled from GPIO.

**Thermal Considerations**

For continuous operation, do not exceed absolute maximum operation junction temperature 125°C. The maximum power dissipation depends on the thermal resistance of IC package, PCB layout, the rate of surroundings airflow and temperature difference between junction to ambient. The maximum power dissipation can be calculated by following formula :

$$P_{D(MAX)} = (T_{J(MAX)} - T_A) / \theta_{JA}$$

Where T<sub>J(MAX)</sub> is the maximum operation junction temperature 125°C, T<sub>A</sub> is the ambient temperature and the θ<sub>JA</sub> is the junction to ambient thermal resistance.

For recommended operating conditions specification of RT9301, where T<sub>J(MAX)</sub> is the maximum junction temperature of the die (125°C) and T<sub>A</sub> is the maximum ambient temperature. The junction to ambient thermal resistance θ<sub>JA</sub> is layout dependent. The thermal resistance θ<sub>JA</sub> for TSOT-23-8 is 262°C/W, and WDFN-8L 3x3 is 108°C/W on the standard JEDEC 51-3 single-layer thermal test board. The maximum power dissipation at T<sub>A</sub> = 25°C can be calculated by following formula :

$$P_{D(MAX)} = (125°C - 25°C) / (262°C/W) = 0.382W \text{ for TSOT-23-8 packages}$$

$$P_{D(MAX)} = (125°C - 25°C) / (108°C/W) = 0.926W \text{ for WDFN-8L 3x3 packages}$$

The maximum power dissipation depends on operating ambient temperature for fixed T<sub>J(MAX)</sub> and thermal resistance θ<sub>JA</sub>. For RT9301 packages, the Figure 1 of derating curves allows the designer to see the effect of rising ambient temperature on the maximum power allowed.

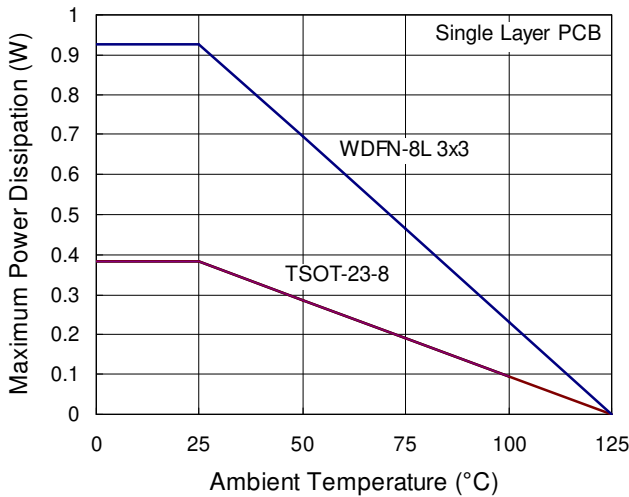

Figure 6. Derating Curves for RT9301 Packages

### Layout Consideration

For best performance, careful PCB layout is necessary. Place all peripheral components as close to the IC as possible. A short connection is highly recommended. The following guidelines should be strictly followed when designing a PCB layout for the RT9301.

1. All the traces of LED and VIN pin running from chip to LEDs should be wide and short to reduce the parasitic connection resistance.
2. Input capacitor ( $C_{IN}$ ) must be placed close to LEDs and connected to ground plane. The anodes of LEDs must be connected to  $C_{IN}$ , not battery directly.
3. Current setting resistors  $R_{SET}$  should be placed as close to the chip as possible.
4. The GND should be connected to a strong ground plane for heat sinking and noise protection.
5. The current setting resistors should be placed as close to the IC as possible.

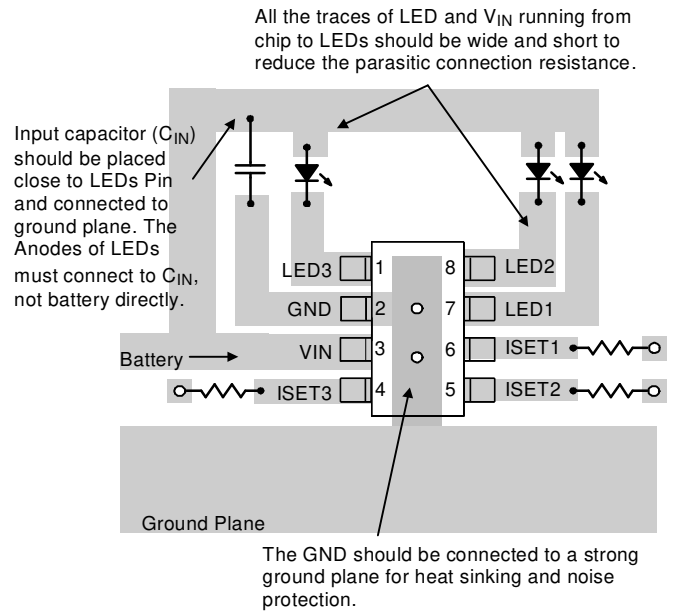

Figure 7. Recommended PCB Layout of TSOT-23-8 Package

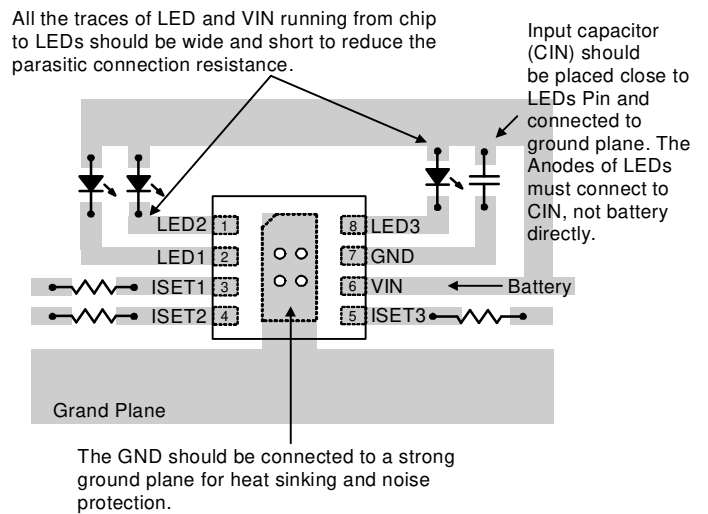
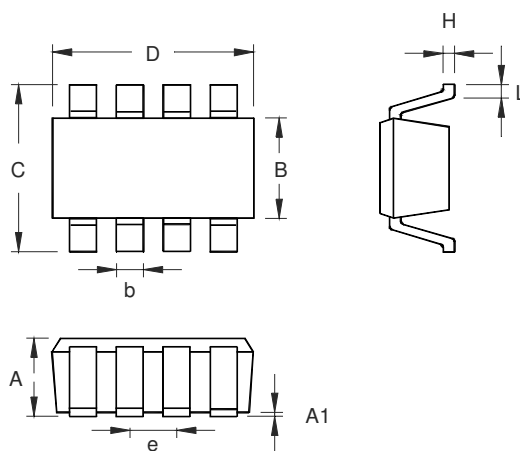

Figure 8. Recommended PCB Layout of WDFN-8L 3x3 Package



**Outline Dimension**



Symbol	Dimensions In Millimeters		Dimensions In Inches	
	Min	Max	Min	Max
A	0.700	1.000	0.028	0.039
A1	0.000	0.100	0.000	0.004
B	1.397	1.803	0.055	0.071
b	0.220	0.380	0.009	0.015
C	2.591	3.000	0.102	0.118
D	2.692	3.099	0.106	0.122
e	0.585	0.715	0.023	0.028
H	0.080	0.254	0.003	0.010
L	0.300	0.610	0.012	0.024

**TSOT-23-8 Surface Mount Package**

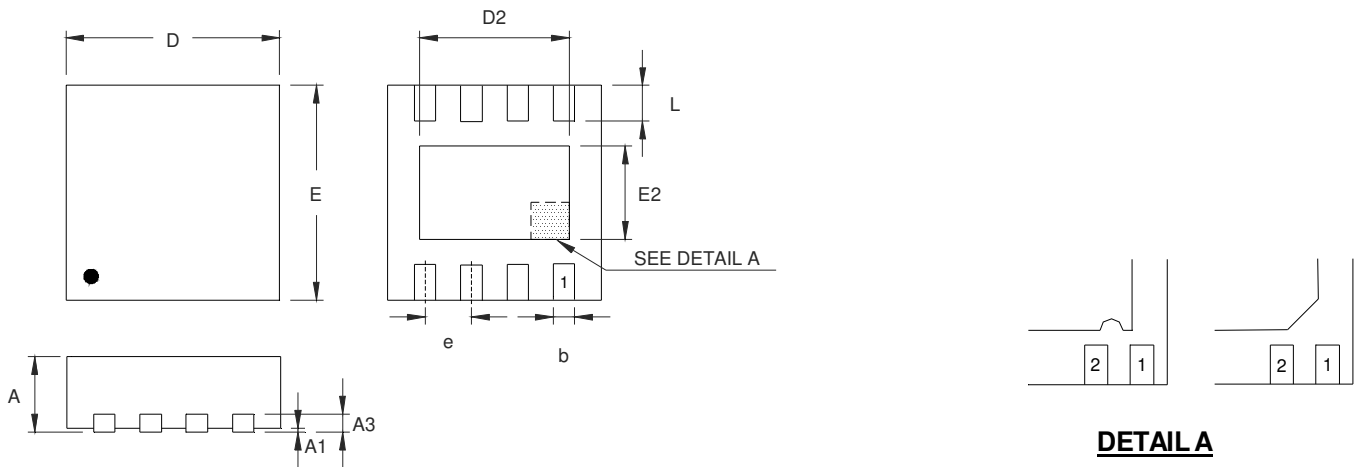

**DETAIL A**

Pin #1 ID and Tie Bar Mark Options

Note : The configuration of the Pin #1 identifier is optional, but must be located within the zone indicated.

Symbol	Dimensions In Millimeters		Dimensions In Inches	
	Min	Max	Min	Max
A	0.700	0.800	0.028	0.031
A1	0.000	0.050	0.000	0.002
A3	0.175	0.250	0.007	0.010
b	0.200	0.300	0.008	0.012
D	2.950	3.050	0.116	0.120
D2	2.100	2.350	0.083	0.093
E	2.950	3.050	0.116	0.120
E2	1.350	1.600	0.053	0.063
e	0.650		0.026	
L	0.425	0.525	0.017	0.021

**W-Type 8L DFN 3x3 Package**

**Richtek Technology Corporation**

Headquarter  
 5F, No. 20, Taiyuen Street, Chupei City  
 Hsinchu, Taiwan, R.O.C.  
 Tel: (8863)5526789 Fax: (8863)5526611

**Richtek Technology Corporation**

Taipei Office (Marketing)  
 5F, No. 95, Minchiuan Road, Hsintien City  
 Taipei County, Taiwan, R.O.C.  
 Tel: (8862)86672399 Fax: (8862)86672377  
 Email: marketing@richtek.com

Information that is provided by Richtek Technology Corporation is believed to be accurate and reliable. Richtek reserves the right to make any change in circuit design, specification or other related things if necessary without notice at any time. No third party intellectual property infringement of the applications should be guaranteed by users when integrating Richtek products into any application. No legal responsibility for any said applications is assumed by Richtek.