

SUBMINIATURE T-3/4 LED DIFFUSED AND CLEAR LAMPS

HIGH EFF. RED	HLMP-6305A	Water Clear	MV6700A	Red Diffused
YELLOW	HLMP-6405A	Water Clear	MV6300A	Yellow Diffused
GREEN	HLMP-6505A	Water Clear	MV6400A	Green Diffused
AIGaAs RED	HLMP-Q105A	Water Clear	HLMP-Q150A	Red Diffused
	HLMP-Q101A	Red Diffused	HLMP-Q155A	Water Clear

PACKAGE DIMENSIONS

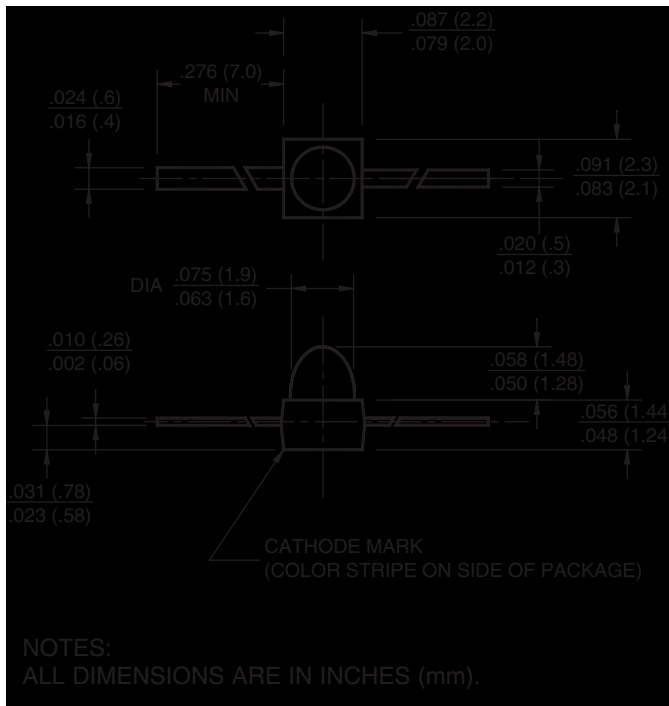

FEATURES

- Subminiature T-3/4 transfer molded
- Low package profile
- Axial leads
- Wide viewing angle
- SMT versions

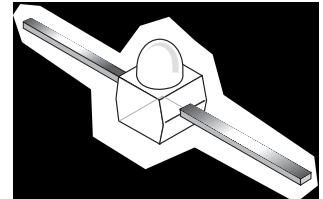

DESCRIPTION

These T-3/4 subminiature LED lamps feature a square-base, transfer molded package for surface mount applications. A tinted diffused or water clear epoxy lens — available in AIGaAs red, high-efficiency red, green, and yellow — produces wide-angle beam emission and sharp on/off contrast. They are available with gullwing lead bends for top mounting, as well as yoke lead bends and Z-bends for mounting to the back of a PCB.

ABSOLUTE MAXIMUM RATING ^c

Parameter	HLMP-6305A MV6700A	HLMP-6405A MV6300A	HLMP-6505A MV6400A	HLMP-Q101A HLMP-Q105A HLMP-Q150A HLMP-Q155A	Units
Power Dissipation	135	85	135	85	mW
Average Forward Current	30	20	30	30	mA
Peak Forward Current (1 μS pulsewidth, 0.1% DF)	90	60	90	300	mA
Lead Soldering Time at 260°C	5	5	5	5	sec
Operating Temperature	-55 to +100	-55 to +100	-50 to +100	-20 to +100	°C
Storage Temperature	-55 to +100	-55 to +100	-50 to +100	-20 to +100	°C

SUBMINIATURE T-3/4 LED

DIFFUSED AND CLEAR LAMPS

HIGH EFF. RED	HLMP-6305A	Water Clear	MV6700A	Red Diffused
YELLOW	HLMP-6405A	Water Clear	MV6300A	Yellow Diffused
GREEN	HLMP-6505A	Water Clear	MV6400A	Green Diffused
AlGaAs RED	HLMP-Q105A	Water Clear	HLMP-Q150A	Red Diffused
	HLMP-Q101A	Red Diffused	HLMP-Q155A	Water Clear

ELECTRICAL / OPTICAL CHARACTERISTICS ($T_A = 25^\circ\text{C}$)

Part Number QTLP-	MV6700A	MV6300A	MV6400A	HLMP-Q150A	Condition
Luminous Intensity (mcd)					$I_F = 10\text{mA}$
Minimum	1.0	1.0	1.0	1.0*	
Typical	3.0	3.0	3.0	1.8*	*Tested at $I_F = 1\text{mA}$
Forward Voltage (V)					$I_F = 10\text{mA}$
Maximum	3.0	3.0	3.0	1.8*	
Typical	1.8	2.0	2.0	1.6*	*Tested at $I_F = 1\text{mA}$
Peak Wavelength (nm)	635	585	565	660	$I_F = 10\text{mA}$
Spectral Line Half Width (nm)	40	36	28	20	$I_F = 10\text{mA}$
Reverse Voltage (V)	5	5	5	5	$I_R = 100\mu\text{A}$
Viewing Angle ($^\circ$)	50	50	50	50	$I_F = 10\text{mA}$

ELECTRICAL / OPTICAL CHARACTERISTICS ($T_A = 25^\circ\text{C}$)

Part Number QTLP-	HLMP-6305A	HLMP-6405A	HLMP-6505A	HLMP-Q101A	HLMP-Q105A/ Q155A	Condition
Luminous Intensity (mcd)						$I_F = 10\text{mA}$
Minimum	3.0	3.0	3.0	22**	20.0**/2.0*	**Tested at $I_F = 1\text{mA}$
Typical	12.0	12.0	12.0	45**	50.0**/4.0*	**Tested at $I_F = 20\text{mA}$
Forward Voltage (V)						$I_F = 10\text{mA}$
Maximum	3.0	3.0	3.0	2.4**	2.4**/1.8*	*Tested at $I_F = 1\text{mA}$
Typical	1.8	2.0	2.0	1.8**	1.8**/1.6*	**Tested at $I_F = 20\text{mA}$
Peak Wavelength (nm)	635	585	565	660	660	$I_F = 10\text{mA}$
Spectral Line Half Width (nm)	40	36	28	20	20	$I_F = 10\text{mA}$
Reverse voltage (V)	5	5	5	5	5	$I_R = 100\mu\text{A}$
Viewing Angle ($^\circ$)	25	25	25	50	25	$I_F = 10\text{mA}$

SUBMINIATURE T-3/4 LED DIFFUSED AND CLEAR LAMPS

HIGH EFF. RED	HLMP-6305A	Water Clear	MV6700A	Red Diffused
YELLOW	HLMP-6405A	Water Clear	MV6300A	Yellow Diffused
GREEN	HLMP-6505A	Water Clear	MV6400A	Green Diffused
AlGaAs RED	HLMP-Q105A	Water Clear	HLMP-Q150A	Red Diffused
	HLMP-Q101A	Red Diffused	HLMP-Q155A	Water Clear

TYPICAL PERFORMANCE CURVES

Fig. 1 Forward Current vs. Forward Voltage

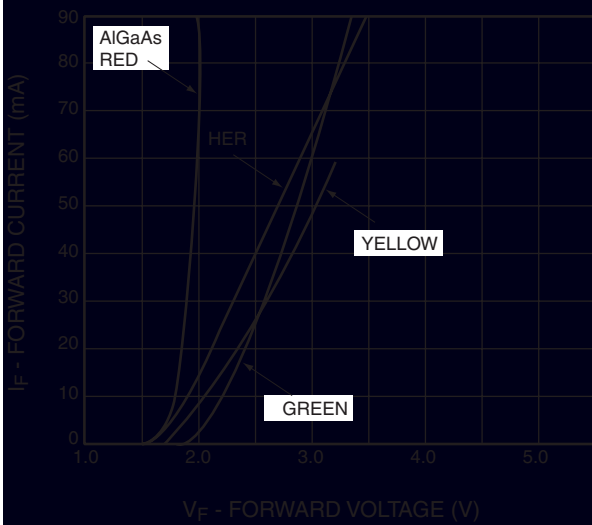

Fig. 2 Relative Luminous Intensity vs. DC Forward Current

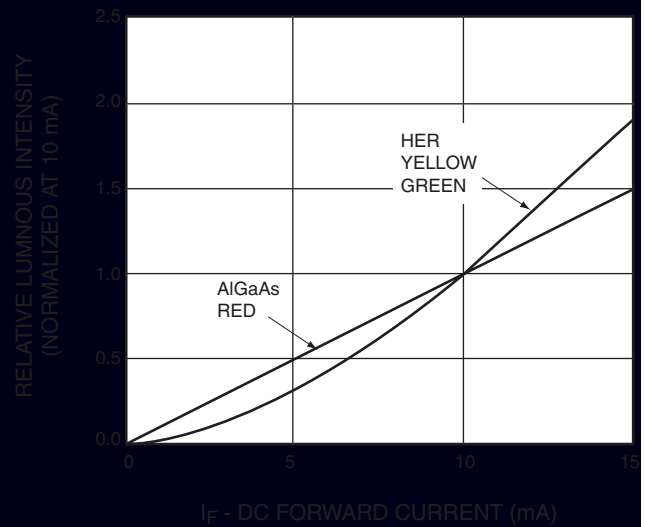
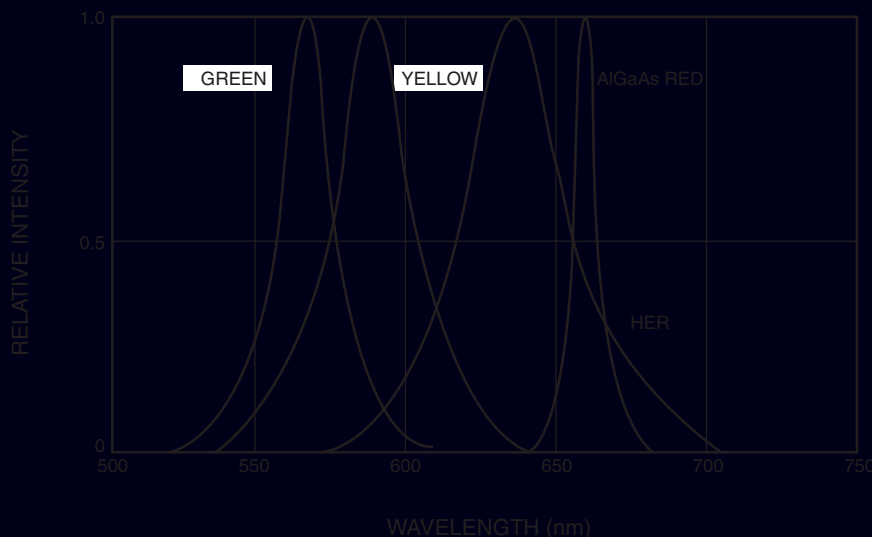

Fig. 3 Relative Intensity vs. Peak Wavelength



SUBMINIATURE T-3/4 LED

DIFFUSED AND CLEAR LAMPS

HIGH EFF. RED	HLMP-6305A	Water Clear	MV6700A	Red Diffused
YELLOW	HLMP-6405A	Water Clear	MV6300A	Yellow Diffused
GREEN	HLMP-6505A	Water Clear	MV6400A	Green Diffused
AlGaAs RED	HLMP-Q105A	Water Clear	HLMP-Q150A	Red Diffused
	HLMP-Q101A	Red Diffused	HLMP-Q155A	Water Clear

RECOMMENDED PRINTED CIRCUIT BOARD PATTERN

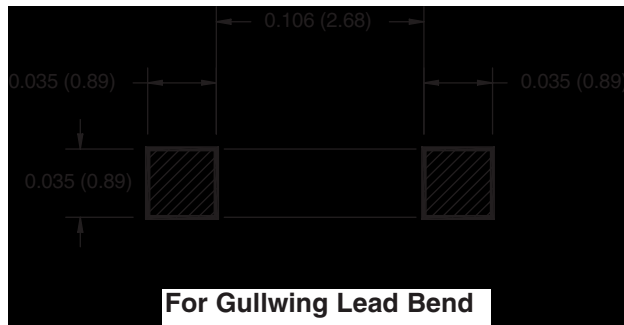

RECOMMENDED REFLOW SOLDERING PROFILE

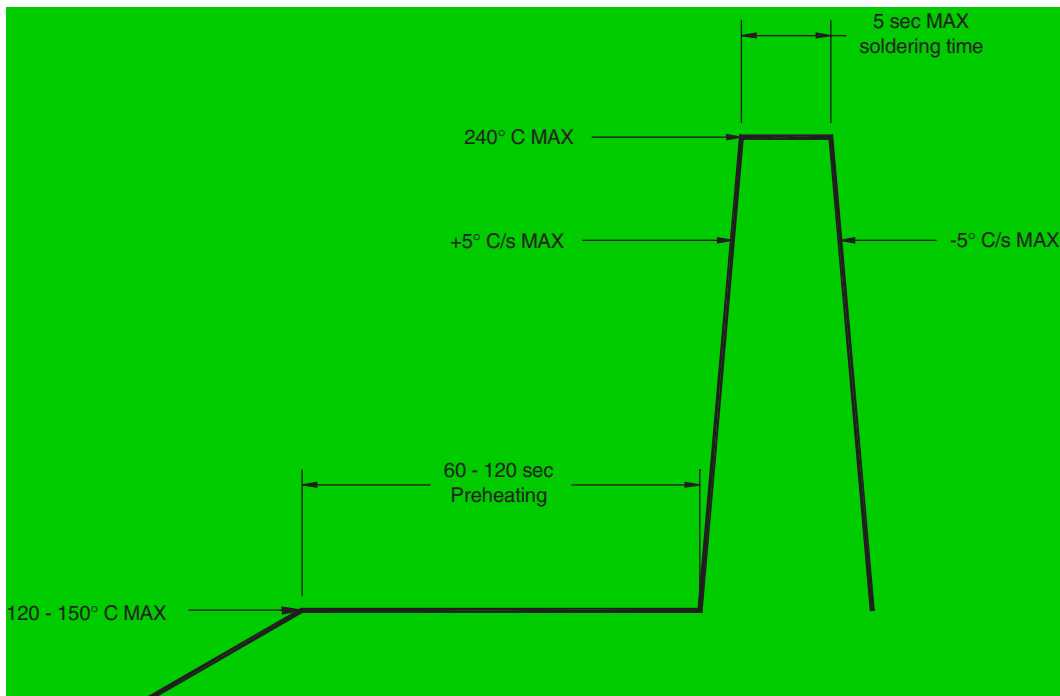

SUBMINIATURE T-3/4 LED DIFFUSED AND CLEAR LAMPS

HIGH EFF. RED	HLMP-6305A	Water Clear	MV6700A	Red Diffused
YELLOW	HLMP-6405A	Water Clear	MV6300A	Yellow Diffused
GREEN	HLMP-6505A	Water Clear	MV6400A	Green Diffused
AlGaAs RED	HLMP-Q105A	Water Clear	HLMP-Q150A	Red Diffused
	HLMP-Q101A	Red Diffused	HLMP-Q155A	Water Clear

GULLWING LEAD CONFIGURATION

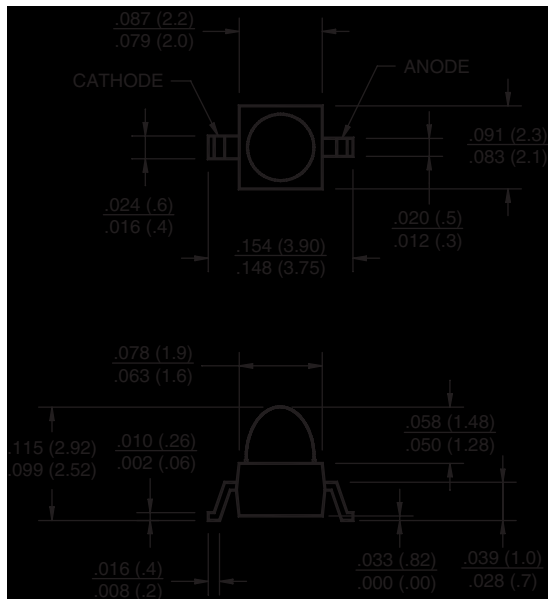

FEATURES

- Available in Gullwing, Yoke and Z-bend lead formings
- Compatible with automatic placement equipment
- Compatible with vapor phase reflow soldering processes
- Long life — solid state reliability
- Reel and tape or bulk packaging available

DESCRIPTION

These subminiature solid state lamps are transfer molded in an axial lead package. They are available in yellow, green, high efficiency red and AlGaAs red in both diffused and water clear lens.

Automatic placement equipment can be used to mount the LEDs on the PC board. The lamps can be mounted using either batch or in line vapor phase reflow solder processes.

NOTES:

ALL DIMENSIONS ARE IN INCHES (mm)

YOKE LEAD CONFIGURATION

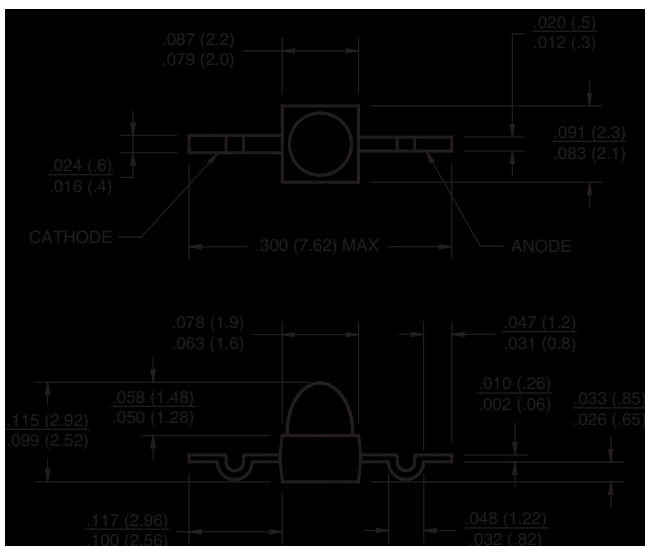

Z-BEND LEAD CONFIGURATION

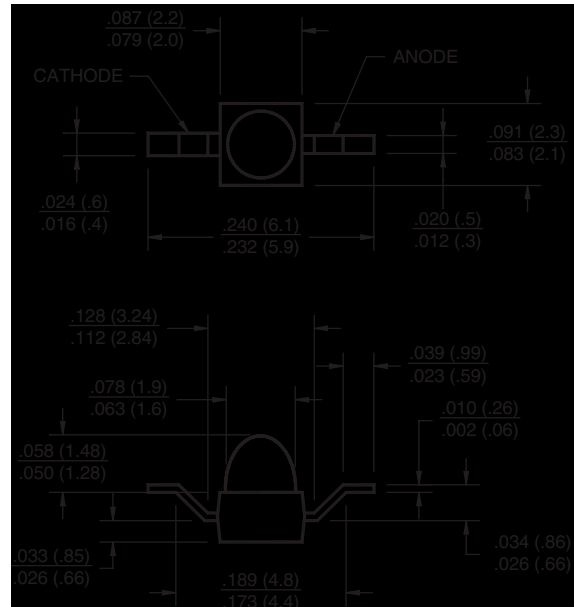



SUBMINIATURE T-3/4 LED DIFFUSED AND CLEAR LAMPS

HIGH EFF. RED	HLMP-6305A	Water Clear	MV6700A	Red Diffused
YELLOW	HLMP-6405A	Water Clear	MV6300A	Yellow Diffused
GREEN	HLMP-6505A	Water Clear	MV6400A	Green Diffused
AlGaAs RED	HLMP-Q105A	Water Clear	HLMP-Q150A	Red Diffused
	HLMP-Q101A	Red Diffused	HLMP-Q155A	Water Clear

DISCLAIMER

FAIRCHILD SEMICONDUCTOR RESERVES THE RIGHT TO MAKE CHANGES WITHOUT FURTHER NOTICE TO ANY PRODUCTS HEREIN TO IMPROVE RELIABILITY, FUNCTION OR DESIGN. FAIRCHILD DOES NOT ASSUME ANY LIABILITY ARISING OUT OF THE APPLICATION OR USE OF ANY PRODUCT OR CIRCUIT DESCRIBED HEREIN; NEITHER DOES IT CONVEY ANY LICENSE UNDER ITS PATENT RIGHTS, NOR THE RIGHTS OF OTHERS.

LIFE SUPPORT POLICY

FAIRCHILD'S PRODUCTS ARE NOT AUTHORIZED FOR USE AS CRITICAL COMPONENTS IN LIFE SUPPORT DEVICES OR SYSTEMS WITHOUT THE EXPRESS WRITTEN APPROVAL OF THE PRESIDENT OF FAIRCHILD SEMICONDUCTOR CORPORATION. As used herein:

1. Life support devices or systems are devices or systems which, (a) are intended for surgical implant into the body, or (b) support or sustain life, and (c) whose failure to perform when properly used in accordance with instructions for use provided in the labeling, can be reasonably expected to result in a significant injury of the user.
2. A critical component in any component of a life support device or system whose failure to perform can be reasonably expected to cause the failure of the life support device or system, or to affect its safety or effectiveness.