

# NHD-5.0-800480TF-22 Controller Board

## TFT Controller Evaluation Board

NHD-	Newhaven Display
5-	5.0" Diagonal
800480-	800xRGBx480 pixels
TF-	Model
22-	22-POS FFC interface (8-bit data) SSD1963 Controller

**Newhaven Display International, Inc.**

2661 Galvin Ct.

Elgin IL, 60124

Ph: 847-844-8795

Fax: 847-844-8796

[www.newhavendisplay.com](http://www.newhavendisplay.com)

[nhtech@newhavendisplay.com](mailto:nhtech@newhavendisplay.com)

[nhsales@newhavendisplay.com](mailto:nhsales@newhavendisplay.com)

## Document Revision History

Revision	Date	Description	Changed by
0	2/25/2014	Initial Release	AK
1	3/4/2021	2D Mechanical Page Redesign; Revised Compatibility to NHD-5.0-800480TF-ATXL# Models	AS

## Functions and Features

- To use for testing, evaluating, or in final production with NHD-5.0-800480TF-ATXL# displays.

# Mechanical Drawing

SYMBOL	REVISION	DATE

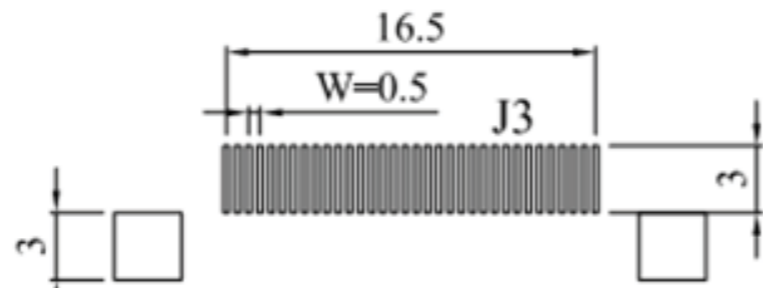
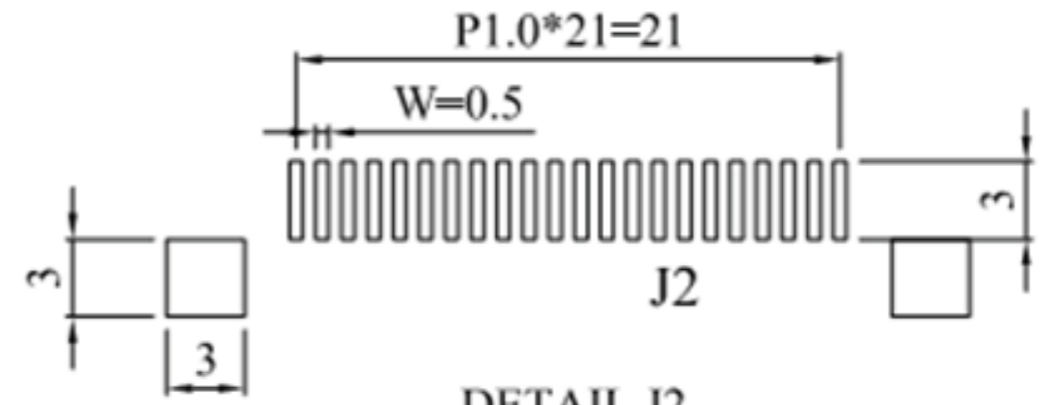
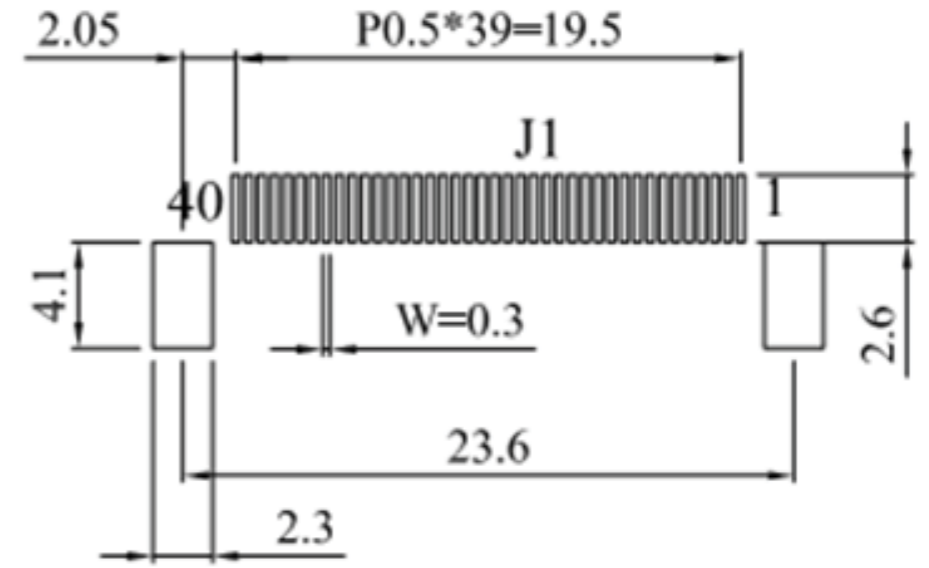
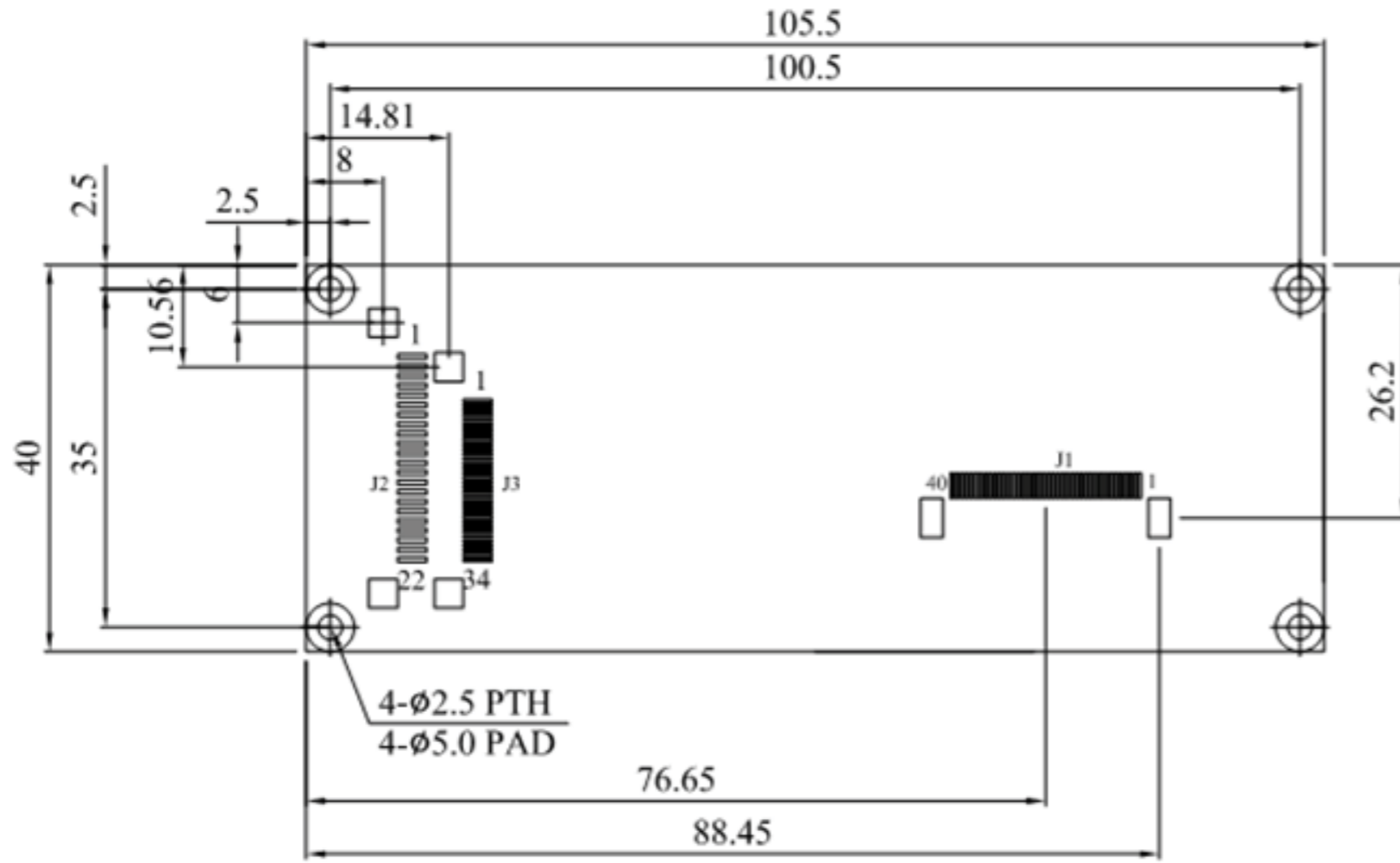

<b>Standard Tolerance:</b> (Unless otherwise specified)  Linear: $\pm 0.3\text{mm}$		
	Drawing/Part Number: <b>NHD-5.0-800480TF-22 Controller Board</b>	Revision: 1.0
<b>Unless otherwise specified:</b> • Dimensions are in Millimeters • Third Angle Projection	Drawn By: A. Shah Drawn Date: 3/4/2021	Approved By: A. Shah Approved Date: 3/4/2021
	Size: A3 Scale: NS	
<b>Do Not Scale Drawing</b>		Sheet 1 of 1
This drawing is solely the property of Newhaven Display International, Inc. The information it contains is not to be disclosed, reproduced or copied in whole or part without written approval from Newhaven Display.		

## Pin Description

### J1 (SSD1963 output to display panel):

Pin No.	Symbol	External Connection	Function Description
1	LED-	LED Power Supply	Backlight Cathode (Ground)
2	LED+	LED Power Supply	Backlight Anode (Power)
3	GND	Power Supply	Ground
4	VDD	Power Supply	Power supply for LCD and logic
5-12	[R0-R7]	MPU	Red Data Signals
13-20	[G0-G7]	MPU	Green Data Signals
21-28	[B0-B7]	MPU	Blue Data Signals
29	GND	Power Supply	Ground
30	CLKIN	MPU	Clock for input data (Rising Edge)
31	STBYB	MPU	1: Normal Operation; 0: Standby Mode
32	HSD	MPU	Line synchronization signal
33	VSD	MPU	Frame synchronization signal
34	DEN	MPU	Data Enable signal
35	NC	-	No Connect
36	GND	Power Supply	Ground
37	XR	Touch Controller	Touch Panel Right
38	YD	Touch Controller	Touch Panel Down
39	XL	Touch Controller	Touch Panel Left
40	YU	Touch Controller	Touch Panel Up

### J2 (SSD1963 input from user's MPU)

Pin No.	Symbol	External Connection	Function Description
1	GND	Power Supply	Ground
2	VDD	Power Supply	Power supply for LCD and logic (3.3V)
3	B/L Enable	Power Supply	Backlight Enable
4	D/C	MPU	Data/Command select. D/C=0: Command, D/C=1: Data
5	/WR	MPU	Active LOW Write signal (8080 mode)
6	/RD	MPU	Active LOW Read signal (8080 mode)
7-14	DB0-DB7	MPU	8-bit bidirectional data bus
15	/CS	MPU	Active LOW Chip Select signal
16	/RESET	MPU	Active LOW Reset signal
17	NC	-	No Connect
18	XR	Touch Panel MPU	Touch Panel Right
19	DISP	MPU	Display On signal
20	YD	Touch Panel MPU	Touch Panel Down
21	XL	Touch Panel MPU	Touch Panel Left
22	YU	Touch Panel MPU	Touch Panel Up

## Electrical Characteristics

Item	Symbol	Condition	Min.	Typ.	Max.	Unit
Operating Temperature Range	Top	Absolute Max	-20	-	+70	°C
Storage Temperature Range	Tst	Absolute Max	-30	-	+80	°C
Supply Voltage	VDD		3.0	3.3	3.6	V
Supply Current	IDD		-	285	-	mA
"H" level input	VIH		0.8*VDD	-	VDD	V
"L" level input	VIL		0	-	0.2*VDD	V
"H" level output	VOH		0.8*VDD	-	VDD	V
"L" level output	VOL		0	-	0.2*VDD	V

## Controller Information

Built-in SSD1963 controller.

Please download specification at [http://www.newhavendisplay.com/app\\_notes/SSD1963.pdf](http://www.newhavendisplay.com/app_notes/SSD1963.pdf)

## Table of Commands

Please download specification at [http://www.newhavendisplay.com/app\\_notes/SSD1963.pdf](http://www.newhavendisplay.com/app_notes/SSD1963.pdf)

## Timing Characteristics

Symbol	Parameter	Min	Typ	Max	Unit
$f_{MCLK}$	System Clock Frequency*	1	-	110	MHz
$t_{MCLK}$	System Clock Period*	$1/f_{MCLK}$	-	-	ns
$t_{PWCSL}$	Control Pulse High Width	Write	13	$1.5 * t_{MCLK}$	ns
		Read	30	$3.5 * t_{MCLK}$	
$t_{PWCSH}$	Control Pulse Low Width	Write (next write cycle)	13	$1.5 * t_{MCLK}$	ns
		Write (next read cycle)	80	$9 * t_{MCLK}$	
		Read	80	$9 * t_{MCLK}$	
$t_{AS}$	Address Setup Time	1	-	-	ns
$t_{AH}$	Address Hold Time	2	-	-	ns
$t_{DSW}$	Write Data Setup Time	4	-	-	ns
$t_{DHW}$	Write Data Hold Time	1	-	-	ns
$t_{PWLW}$	Write Low Time	12	-	-	ns
$t_{DHR}$	Read Data Hold Time	1	-	-	ns
$t_{ACC}$	Access Time	32	-	-	ns
$t_{PWLr}$	Read Low Time	36	-	-	ns
$t_R$	Rise Time	-	-	0.5	ns
$t_F$	Fall Time	-	-	0.5	ns
$t_{CS}$	Chip select setup time	2	-	-	ns
$t_{CSH}$	Chip select hold time to read signal	3	-	-	ns

\* System Clock denotes external input clock (PLL-bypass) or internal generated clock (PLL-enabled)

### Write Cycle:

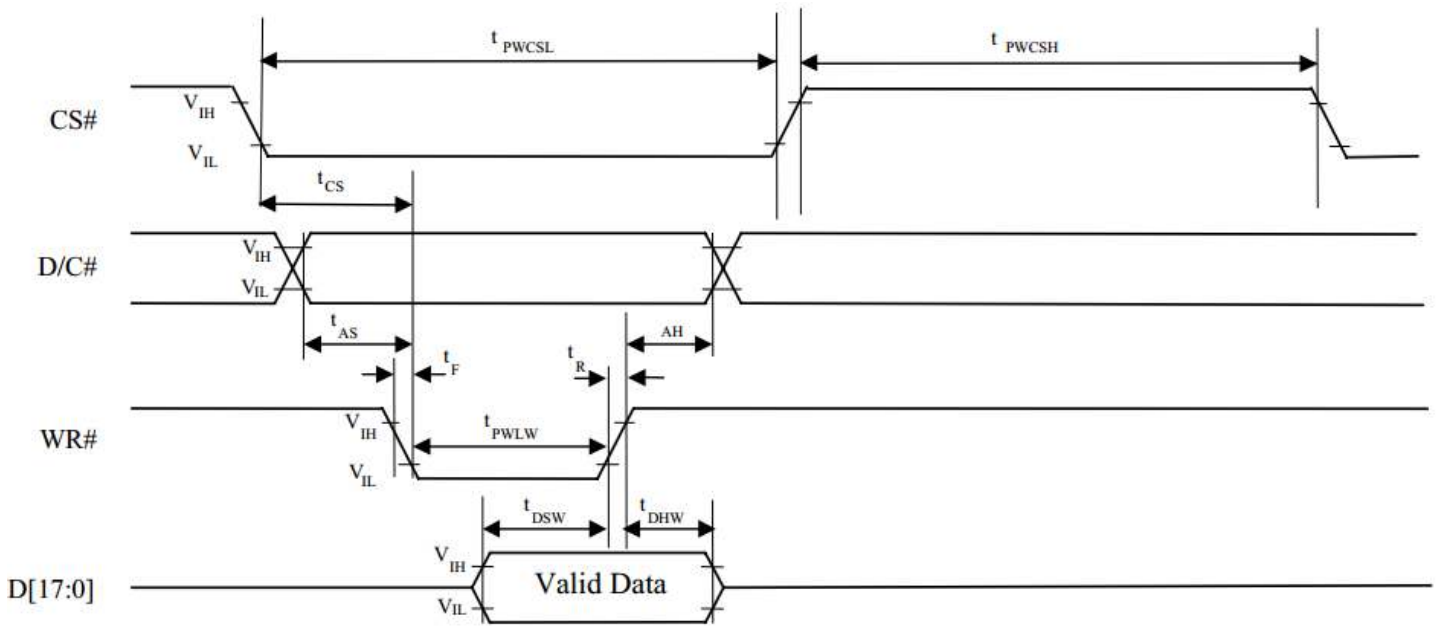

### Read Cycle:

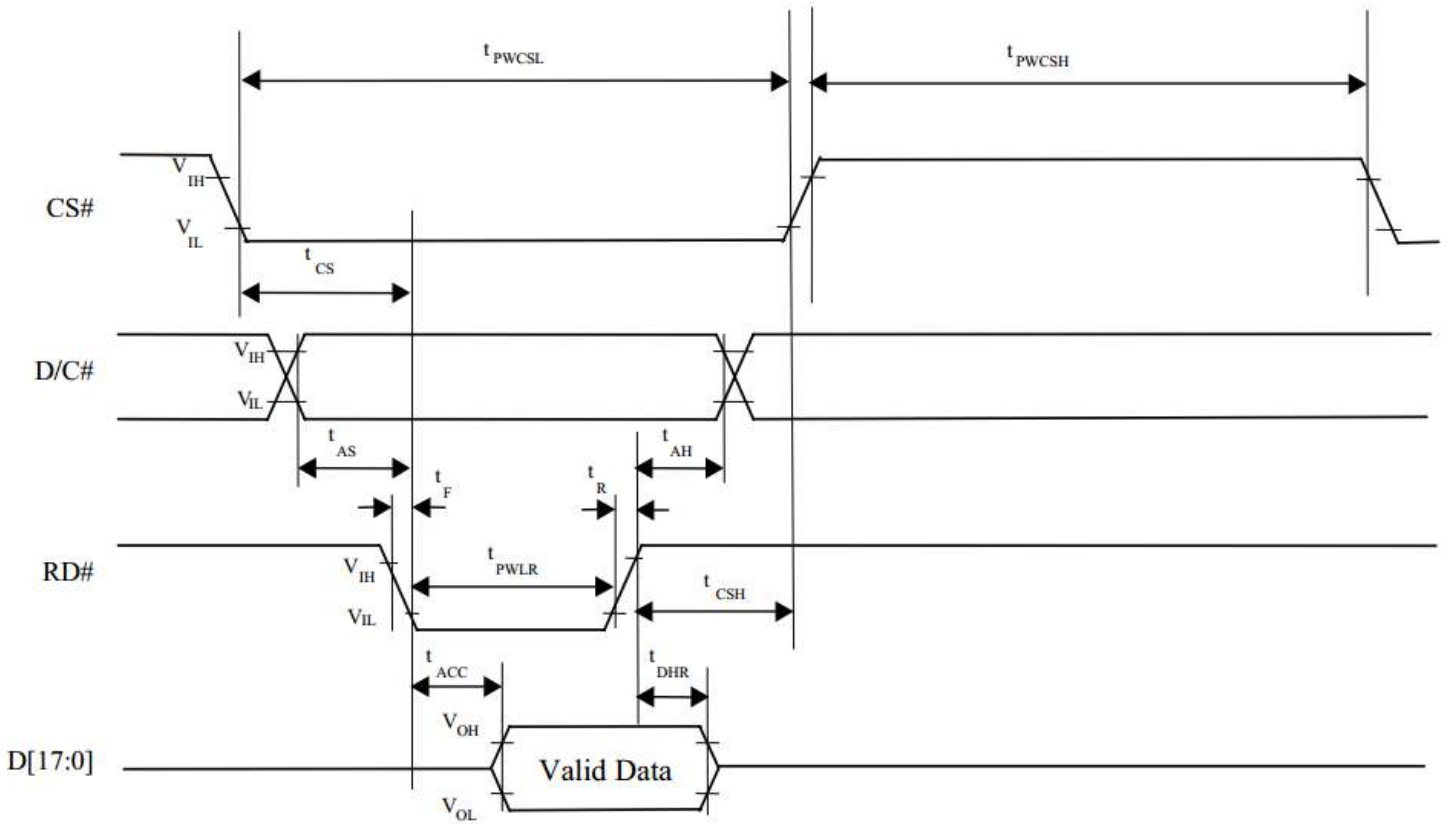

## Quality Information

Test Item	Content of Test	Test Condition	Note
High Temperature storage	Endurance test applying the high storage temperature for a long time.	+80°C , 200hrs	2
Low Temperature storage	Endurance test applying the low storage temperature for a long time.	-30°C , 200hrs	1,2
High Temperature Operation	Endurance test applying the electric stress (voltage & current) and the high thermal stress for a long time.	+70°C 200hrs	2
Low Temperature Operation	Endurance test applying the electric stress (voltage & current) and the low thermal stress for a long time.	-20°C , 200hrs	1,2
High Temperature / Humidity Storage	Endurance test applying the electric stress (voltage & current) and the high thermal with high humidity stress for a long time.	+60°C , 90% RH , 96hrs	1,2
Thermal Shock resistance	Endurance test applying the electric stress (voltage & current) during a cycle of low and high thermal stress.	-20°C,30min -> 25°C,5min -> 70°C,30min = 1 cycle 10 cycles	
Vibration test	Endurance test applying vibration to simulate transportation and use.	10-55Hz , 15mm amplitude. 60 sec in each of 3 directions X,Y,Z For 15 minutes	3
Static electricity test	Endurance test applying electric static discharge.	VS=800V, RS=1.5kΩ, CS=100pF One time	

**Note 1:** No condensation to be observed.

**Note 2:** Conducted after 4 hours of storage at 25°C, 0%RH.

**Note 3:** Test performed on product itself, not inside a container.

## Precautions for using LCDs/LCMs

See Precautions at [www.newhavendisplay.com/specs/precautions.pdf](http://www.newhavendisplay.com/specs/precautions.pdf)

## Warranty Information and Terms & Conditions

[http://www.newhavendisplay.com/index.php?main\\_page=terms](http://www.newhavendisplay.com/index.php?main_page=terms)