

NANOMUSCLE

Advanced Miniature Motion

RS-70-CE 1131 Rotary Actuator

System Includes

- Bidirectional 60° rotary actuator
- Built-in overstrain/abuse protection
- End-stop indicator
- Position feedback (for optional position control)

Benefits

- Silent operation
- Miniature size
- Integrated direct-drive design
- No gearbox or clutch required

Applications

- Moving eyes for dolls and plush toys
- Lip-sync for moving mouths
- Creature animation and articulation
- Controlled movement of latches and levers

The best way to evaluate NanoMuscle actuators is by purchasing our Toy Development Kit. Order yours today!

Contact Information:
NanoMuscle, Inc.
2545 West 10th St.
Suite A
Antioch, CA 94509

Office: 925-776-4700
Sales: 925-776-4726
Fax: 925-755-9572
www.NanoMuscle.com
sales@nanomuscle.com

The NanoMuscle RS-70-CE 1131 is a bidirectional rotary motion actuator that rotates up to 60° to provide smooth, silent movement in a miniature package. It is a complete motion solution. Unlike regular motors, the actuator is an integrated design for direct drive. There is no gearbox or clutch necessary, which saves cost, reduces space required, and simplifies product design.

With a minimum of external components, the actuator can provide a simple rotate, hold, and return motion. Position and speed control can be obtained by using the pulse width modulated (PWM) output available on virtually all inexpensive 4-bit or 8-bit speech ICs, LCD controllers, and other general-purpose microprocessors. Please refer to the RS series actuator user guide for more details.

Performance

Torque: A unique feature of the NanoMuscle rotary actuator is that it provides constant torque of **12.2 g-cm** in both directions, for a full range of smooth motion.

Speed: A full, clockwise 0 – 60° rotation with 3.0V applied takes a minimum of **300 ms**, while the counter-clockwise (60 – 0° return) requires no power applied and takes a minimum of **600 ms**. Faster rotate speeds are possible with higher voltage applied. Speed control and/or symmetry of motion can be achieved via software running on an inexpensive microprocessor as mentioned above.



External Dimensions

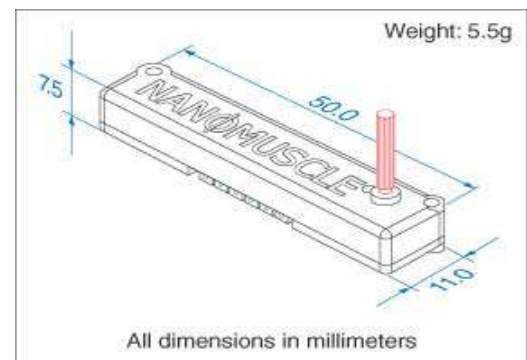

Electrical Specifications

- Operating voltage range: 2.5 – 6.4V
- Nominal voltage range: 4.5 – 6.0V
- Hold current for full-rated torque: 68 mA (@4.5V), 52 mA (@6.0V)
- Battery life: performing a continuous test using alkaline batteries, holding the shaft at full-rated torque and moving to a new position every 4 seconds
 - 3 AA cells will last 18.8 hours
 - 2 AA cells will last 12.5 hours
 - 3 AAA cells will last 9 hours

The lower limit of battery life is when the battery voltage drops to 2.5V.