

Low power motor control board featuring the SLLIMM™ STGIPN3H60 and MCU STM32F100C6T6B

Data brief

Features

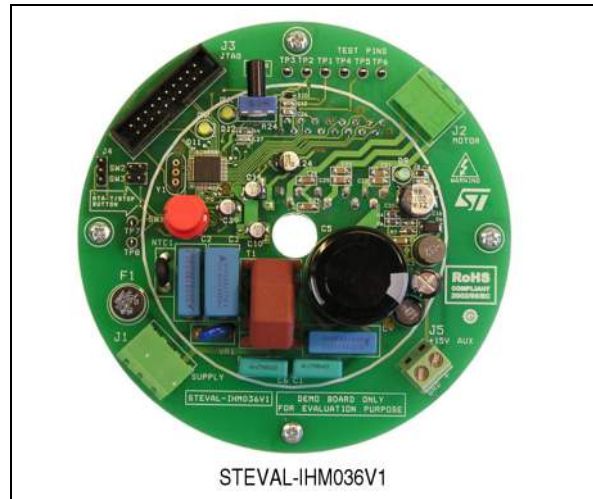
- Complete 100 W power inverter solution
- HV supply: 90 to 285 V AC or direct DC at 125 to 400 V DC
- Input inrush limiter based on NTC resistor
- Single shunt resistor current-sensing method
- Overtemperature and overcurrent hardware protection
- Compact and safe design
- Test points available to allow further evaluation
- RoHS compliant

Description

The purpose of the STEVAL-IHM036V1 demonstration board is to present a universal, fully-tested design consisting of a 3-phase inverter bridge based on the 600 V, 3 A small low-loss intelligent molded module (SLLIMM™) STGIPN3H60 and the STM32F100C6T6B MCU.

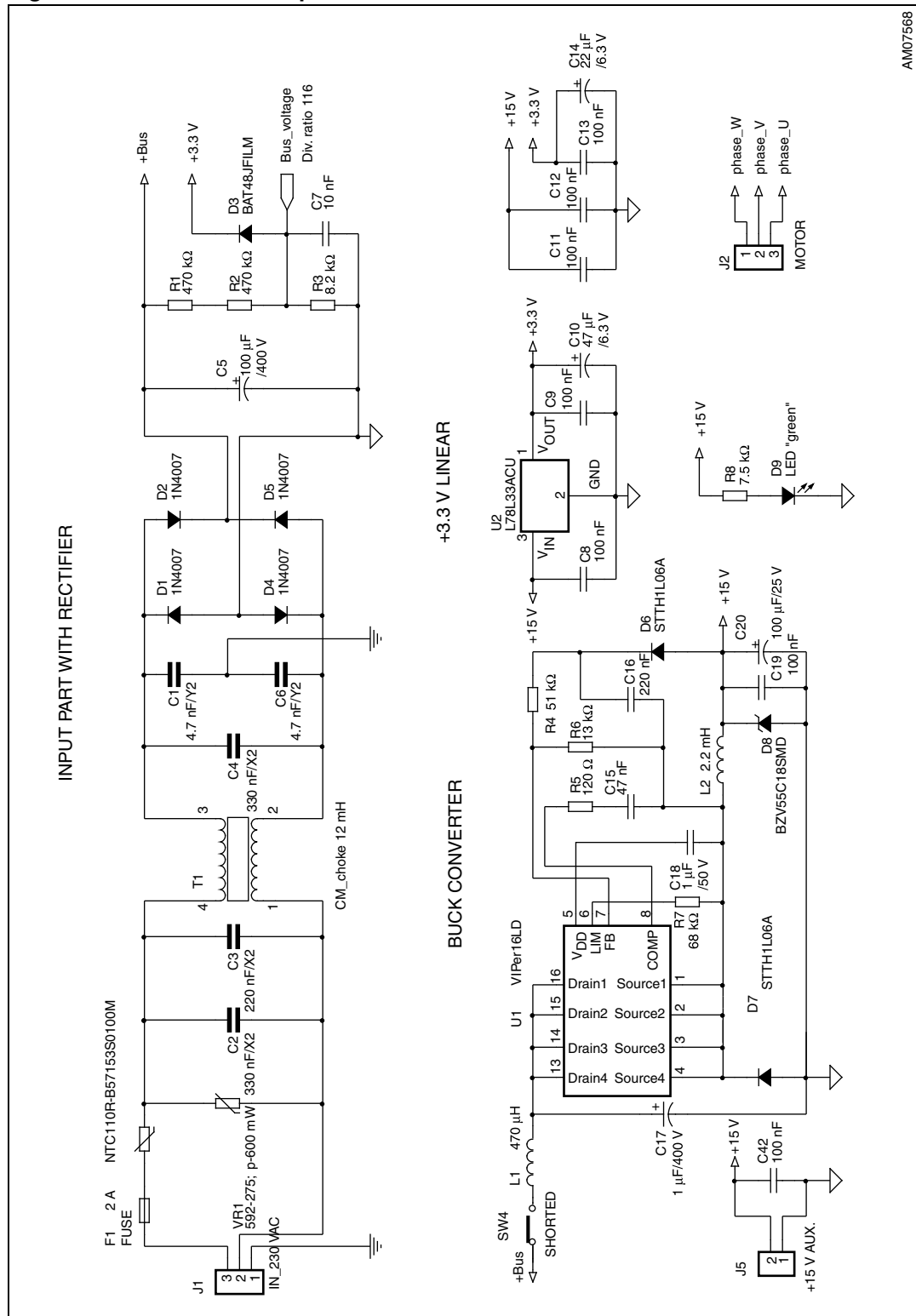
The SLLIMM™ consists of short-circuit rugged IGBT's with negative temperature coefficient. Additional auxiliary functions are undervoltage lockout and smart shut-down.

Thanks to these advanced characteristics the system achieves fast and accurate conditioning of the current feedback, rendering it capable of meeting the typical requirements for field-oriented control (FOC).



1 Schematic diagram

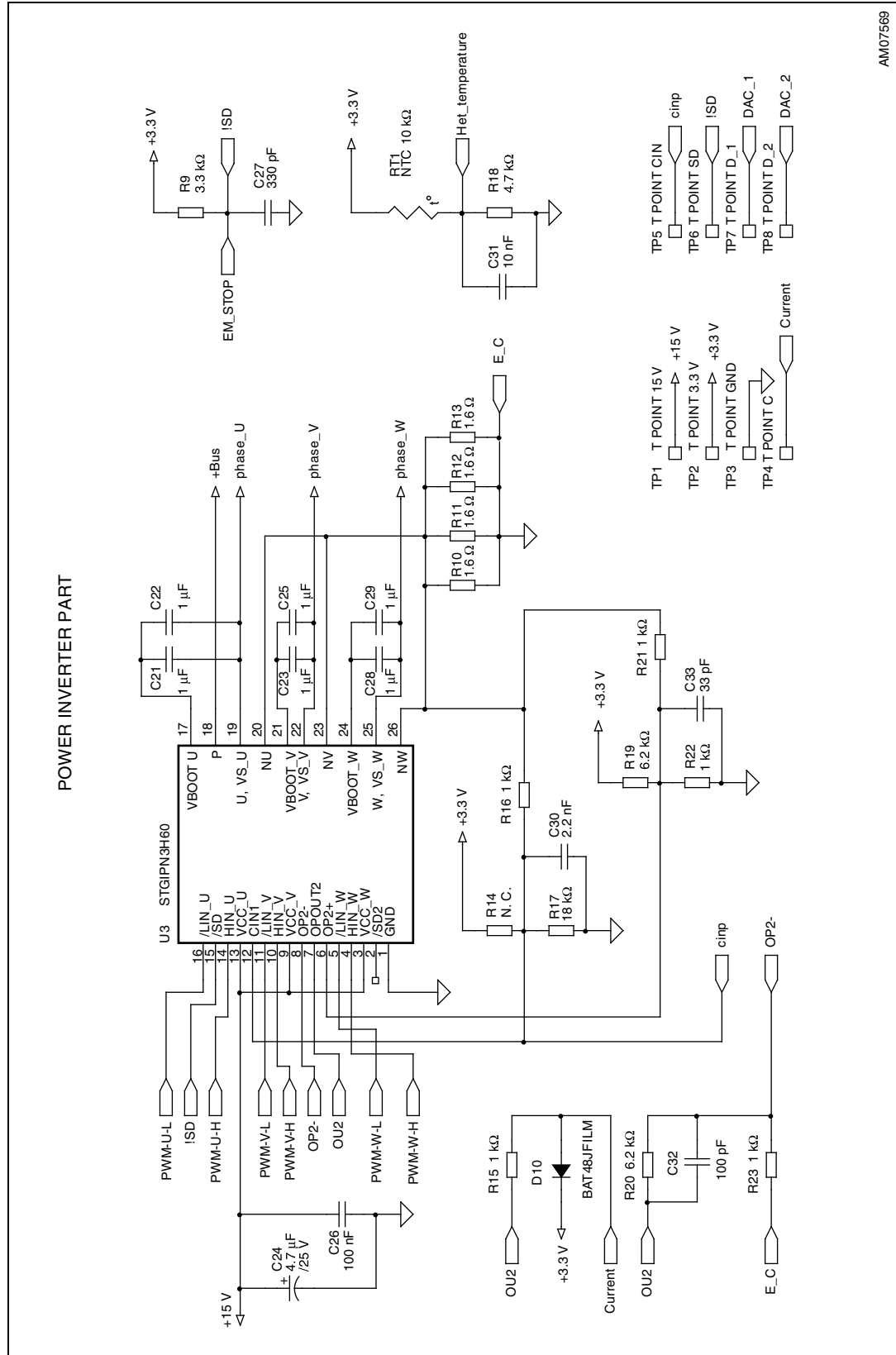
Figure 1. Power inverter part



AM07568

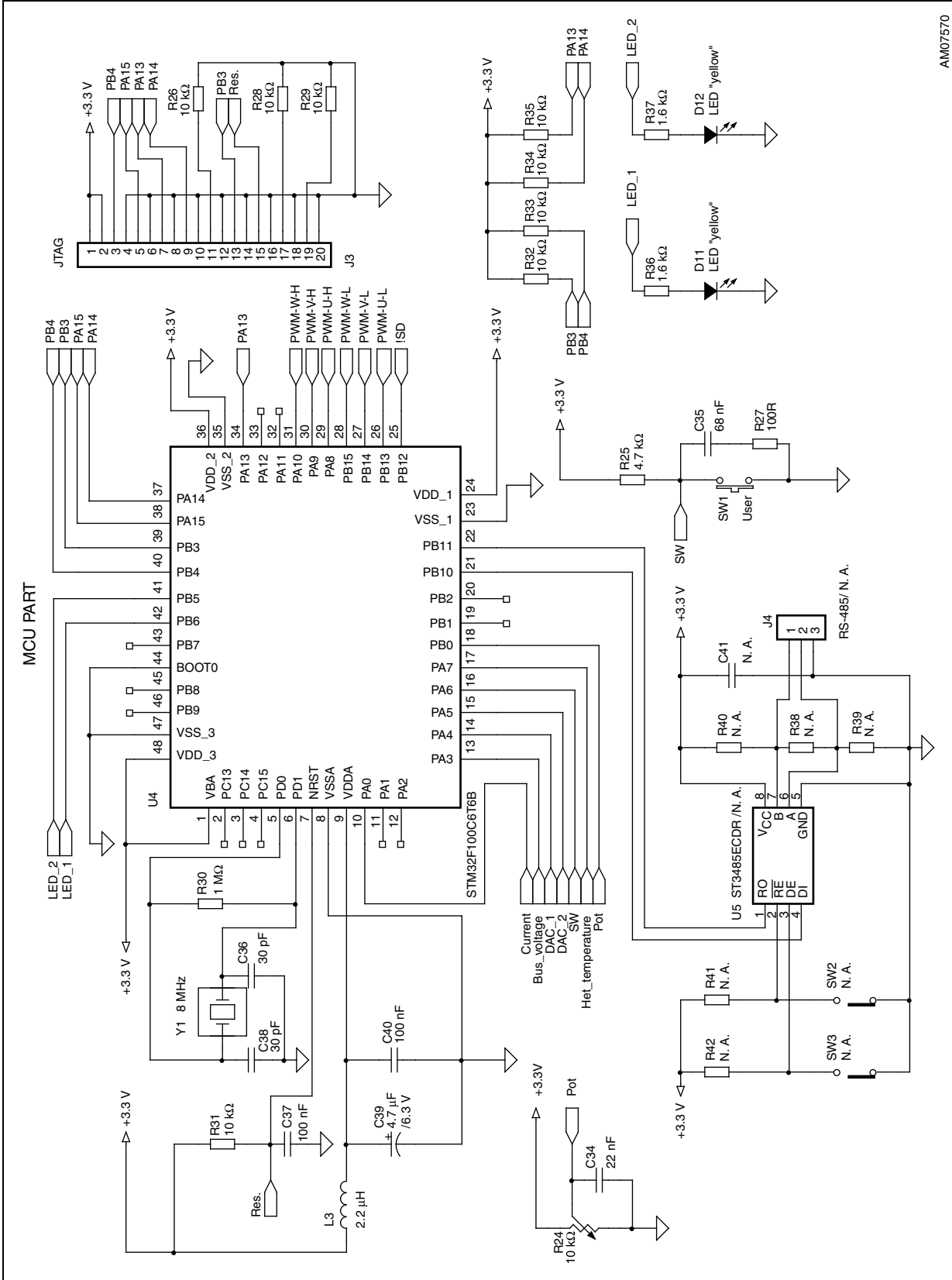


Figure 2. Input part with rectifier, buck converter and buck 3.3 V linear



AM07569

Figure 3. MCU part



AM07570



2 Revision history

Table 1. Document revision history

Date	Revision	Changes
30-Nov-2011	1	Initial release.
14-May-2012	2	Updated: photo in the cover page, Figure 1 , 2 and 3

Please Read Carefully:

Information in this document is provided solely in connection with ST products. STMicroelectronics NV and its subsidiaries ("ST") reserve the right to make changes, corrections, modifications or improvements, to this document, and the products and services described herein at any time, without notice.

All ST products are sold pursuant to ST's terms and conditions of sale.

Purchasers are solely responsible for the choice, selection and use of the ST products and services described herein, and ST assumes no liability whatsoever relating to the choice, selection or use of the ST products and services described herein.

No license, express or implied, by estoppel or otherwise, to any intellectual property rights is granted under this document. If any part of this document refers to any third party products or services it shall not be deemed a license grant by ST for the use of such third party products or services, or any intellectual property contained therein or considered as a warranty covering the use in any manner whatsoever of such third party products or services or any intellectual property contained therein.

UNLESS OTHERWISE SET FORTH IN ST'S TERMS AND CONDITIONS OF SALE ST DISCLAIMS ANY EXPRESS OR IMPLIED WARRANTY WITH RESPECT TO THE USE AND/OR SALE OF ST PRODUCTS INCLUDING WITHOUT LIMITATION IMPLIED WARRANTIES OF MERCHANTABILITY, FITNESS FOR A PARTICULAR PURPOSE (AND THEIR EQUIVALENTS UNDER THE LAWS OF ANY JURISDICTION), OR INFRINGEMENT OF ANY PATENT, COPYRIGHT OR OTHER INTELLECTUAL PROPERTY RIGHT.

UNLESS EXPRESSLY APPROVED IN WRITING BY TWO AUTHORIZED ST REPRESENTATIVES, ST PRODUCTS ARE NOT RECOMMENDED, AUTHORIZED OR WARRANTED FOR USE IN MILITARY, AIR CRAFT, SPACE, LIFE SAVING, OR LIFE SUSTAINING APPLICATIONS, NOR IN PRODUCTS OR SYSTEMS WHERE FAILURE OR MALFUNCTION MAY RESULT IN PERSONAL INJURY, DEATH, OR SEVERE PROPERTY OR ENVIRONMENTAL DAMAGE. ST PRODUCTS WHICH ARE NOT SPECIFIED AS "AUTOMOTIVE GRADE" MAY ONLY BE USED IN AUTOMOTIVE APPLICATIONS AT USER'S OWN RISK.

Resale of ST products with provisions different from the statements and/or technical features set forth in this document shall immediately void any warranty granted by ST for the ST product or service described herein and shall not create or extend in any manner whatsoever, any liability of ST.

ST and the ST logo are trademarks or registered trademarks of ST in various countries.

Information in this document supersedes and replaces all information previously supplied.

The ST logo is a registered trademark of STMicroelectronics. All other names are the property of their respective owners.

© 2012 STMicroelectronics - All rights reserved

STMicroelectronics group of companies

Australia - Belgium - Brazil - Canada - China - Czech Republic - Finland - France - Germany - Hong Kong - India - Israel - Italy - Japan - Malaysia - Malta - Morocco - Philippines - Singapore - Spain - Sweden - Switzerland - United Kingdom - United States of America

www.st.com