



MAX2205–MAX2208 Evaluation Kits

General Description

The MAX2205–MAX2208 evaluation kits (EV kits) simplify the evaluation of the MAX2205–MAX2208 RF power detectors. They enable testing of all functions, with no additional support circuitry. The RF input utilizes a 50Ω SMA connector for convenient connection to test equipment.

Features

- ◆ +2.7V to +5V Single-Supply Operation
- ◆ 50Ω SMA Connector on RF Input
- ◆ Fully Assembled and Tested

Ordering Information

PART	TEMP RANGE	IC PACKAGE
MAX2205EVKIT	-40°C to +85°C	2 × 2 UCSP
MAX2206EVKIT	-40°C to +85°C	2 × 2 UCSP
MAX2207EVKIT	-40°C to +85°C	2 × 2 UCSP
MAX2208EVKIT	-40°C to +85°C	2 × 2 UCSP

MAX2205 Component List

DESIGNATION	QTY	DESCRIPTION
C1	1	47pF ±5% ceramic capacitor (0402) Murata GRP1555CIH470J
C2	1	27pF ±5% ceramic capacitor (0402) Murata GRP1555CIH270J
C3	1	22μF electrolytic capacitor, B case size AVX TAJB226K010
C4	1	Not installed
SMA	1	SMA connector, edge mount, 0.031in EFJohnson 142-0701-881
J1, J2	2	2-pin headers, 0.1in centers
J3	1	1-pin header
JU1	1	3-pin header, 0.1in center
R1	1	10kΩ ±5% resistor (0402)
R2	1	680Ω ±5% resistor (0402)
R3–R6	4	200Ω ±5% resistors (0402)
U1	1	MAX2205EBS

MAX2206/MAX2207/MAX2208 Component List

DESIGNATION	QTY	DESCRIPTION
C1	1	47pF ±5% ceramic capacitor (0402) Murata GRP1555CIH470J
C2	1	27pF ±5% ceramic capacitor (0402) Murata GRP1555CIH270J
C3	1	22μF capacitor, electrolytic, B case size AVX TAJB226K010
C4	1	Not installed
SMA	1	SMA connector, edge mount, 0.031in EFJohnson 142-0701-881
J1, J2	2	12-pin headers, 0.1in centers
J3	1	1-pin header
JU1	1	3-pin header, 0.1in center
R1	1	240Ω ±5% resistor (0402)
R2	1	0Ω ±5% resistor (0402) (MAX2207/MAX2208), 10Ω ±5% resistor (MAX2206)
U1	1	MAX2206EBS (MAX2206EVKIT) MAX2207EBS (MAX2207EVKIT) MAX2208EBS (MAX2208EVKIT)

Evaluate: MAX2205–MAX2208

MAX2205–MAX2208 Evaluation Kits

Quick Start

The MAX2205–MAX2208 EV kits are fully assembled and factory tested. Follow the instructions in the *Connections and Setup* section for proper device setup.

Connections and Setup

This section provides a step-by-step guide to operating the EV kits and testing the devices' functions. Do not turn on DC power or RF signal generators until all connections are made:

- 1) Set the $\overline{\text{SHDN}}$ jumper (JU1) on the EV kit to ON. This enables the device.
- 2) Connect a DC supply set to +2.85V (through a DMM, if desired) to the VCC and GND terminals on the EV kit. If available, set the current limit to 10mA. Do not turn on the supply.
- 3) Connect the output (J3) to a DMM to measure output voltage.
- 4) Set the signal generator output to +15dBm, $f = 800\text{MHz}$. For the MAX2206, use a CW input from the signal generator to the RF input. For the MAX2207, use a TDMA input. For the MAX2205/MAX2208, use a CDMA input. Using the power meter, determine the actual power output of the signal generator. Use this value to determine proper operation of the part.
- 5) Connect the signal generator to the SMA connector. Do not turn on the signal generator.
- 6) Turn on the DC supply; the supply current should read approximately 3.5mA (MAX2206) or 2mA (MAX2205/MAX2207/MAX2208), depending on the part being tested.
- 7) Activate the signal generator. The output voltage should read approximately +1.8V for the MAX2206/MAX2207/MAX2208, or +0.25V for the MAX2205.

Test Equipment Required

EQUIPMENT	DESCRIPTION
Signal Generator with Digital Modulation Capabilities	Capable of delivering continuous wave (CW), CDMA, and TDMA signals with +15dBm output power
Power Meter	To accurately measure the power into the RF input
Power Supply	Capable of up to 10mA at +2.7V to +6V
Digital Multimeters (DMMs)	To measure output voltage and supply and output current

MAX2205–MAX2208 Evaluation Kits

Evaluate: MAX2205–MAX2208

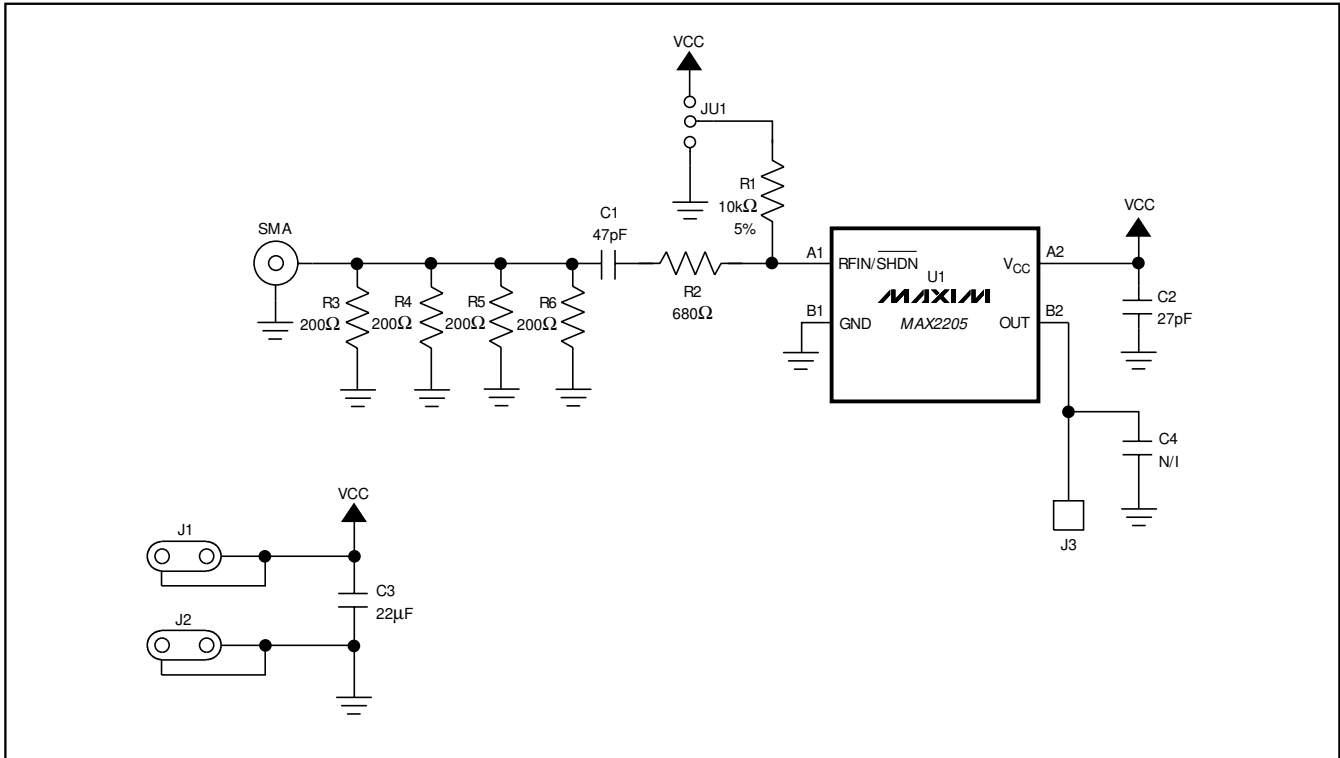

Figure 1. MAX2205 EV Kit Schematic

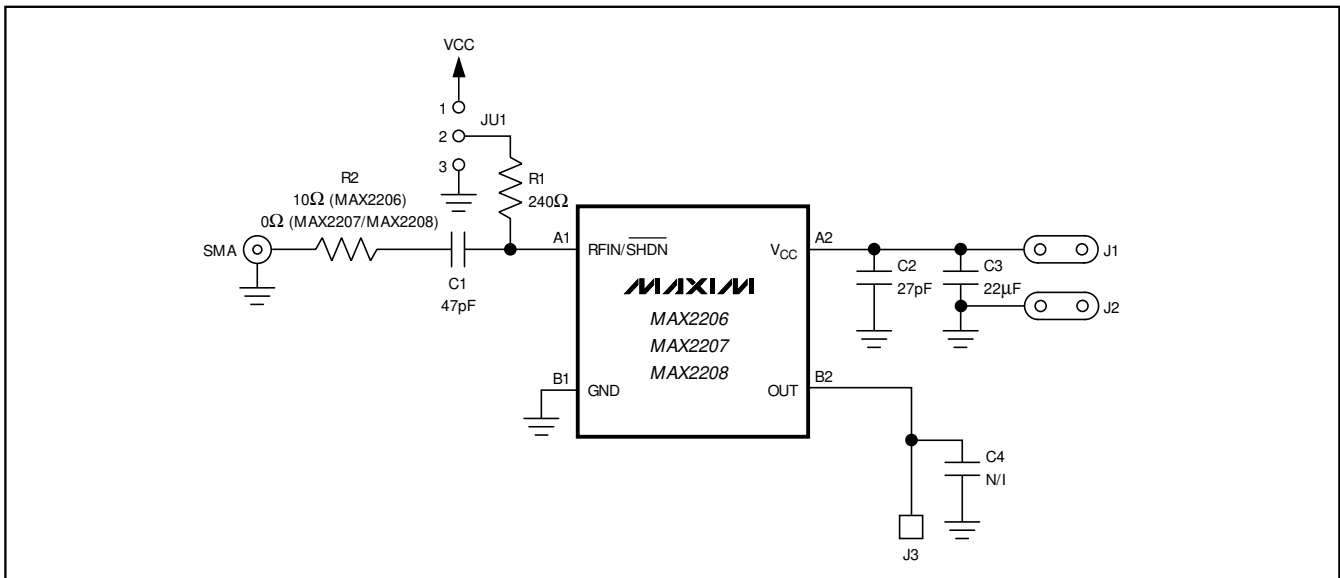

Figure 2. MAX2206/MAX2207/MAX2208 EV Kit Schematic

MAX2205-MAX2208 Evaluation Kits

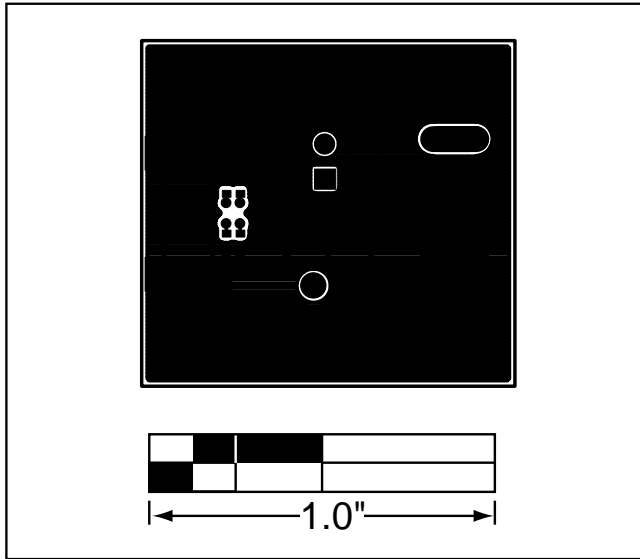

Figure 3. MAX2205 EV Kit Component Placement Guide—Secondary/Bottom Component Side

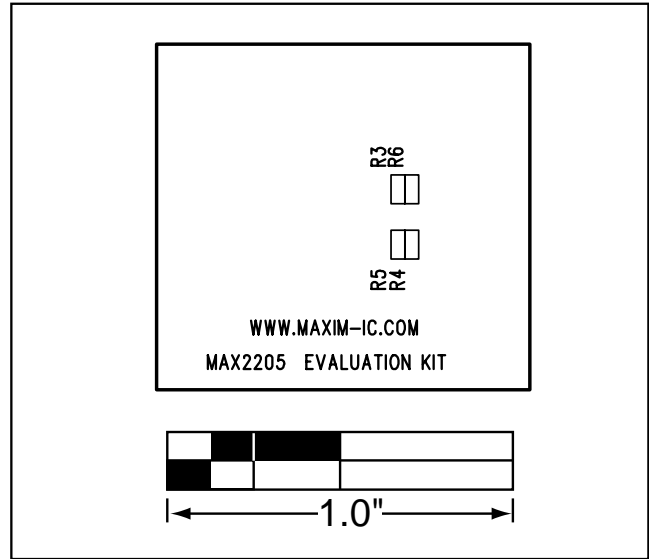

Figure 4. MAX2205 EV Kit Component Placement Guide—Bottom Silkscreen

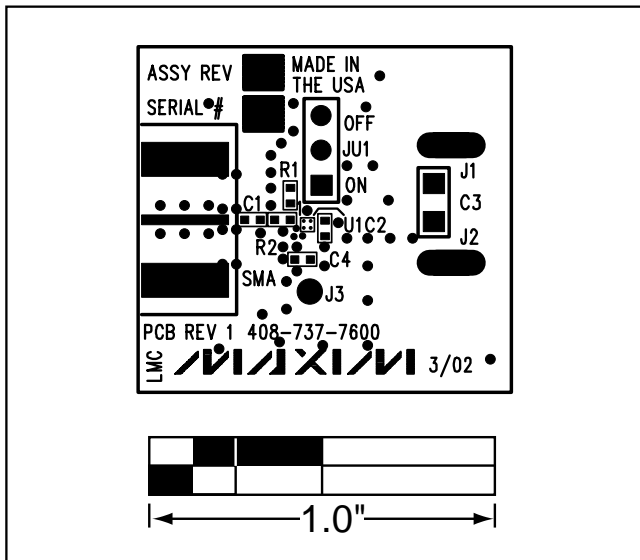

Figure 5. MAX2205 EV Kit Component Placement Guide—Top Silkscreen

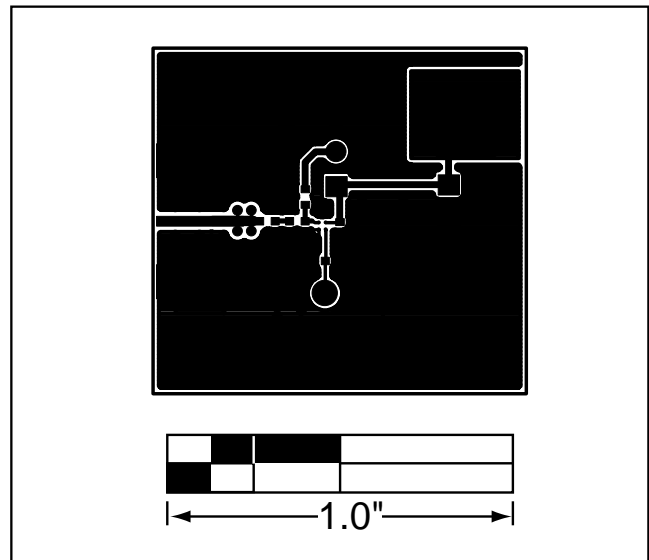

Figure 6. MAX2205 EV Kit Component Placement Guide—Component Side

MAX2205–MAX2208 Evaluation Kits

Evaluate: MAX2205–MAX2208

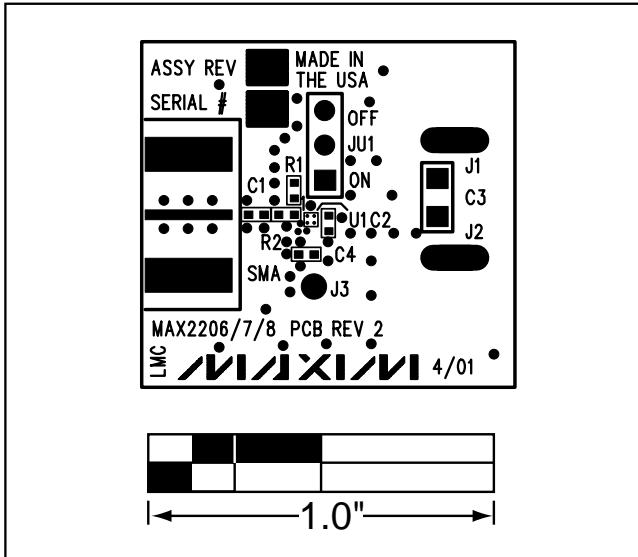

Figure 7. MAX2206/MAX2207/MAX2208 EV Kit Component Placement Guide—Top Silkscreen

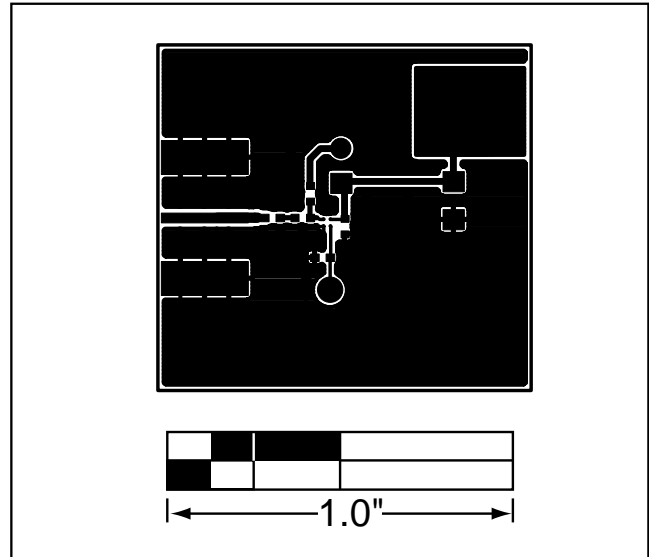

Figure 8. MAX2206/MAX2207/MAX2208 EV Kit Component Placement Guide—Component Side

Maxim cannot assume responsibility for use of any circuitry other than circuitry entirely embodied in a Maxim product. No circuit patent licenses are implied. Maxim reserves the right to change the circuitry and specifications without notice at any time.

Maxim Integrated Products, 120 San Gabriel Drive, Sunnyvale, CA 94086 408-737-7600 _____ 5