



## COMPLEX FUNCTIONS

### MC4300/MC4000 Series

The MTTT complex functions are designed for digital applications in the medium to high-speed range.

These MTTT devices provide significant reduction in package count and increased logic per function over devices in the basic MTTT and MDTL families.

#### FUNCTIONS AND CHARACTERISTICS ( $V_{CC} = 5.0 \text{ V}$ , $T_A = 25^\circ\text{C}$ )

All devices shown can be used with all MTTT and MDTL devices; however, the loading factors shown reflect use with other devices in the same MC-number series unless otherwise noted.

Function	Operating Temperature Range		Output Loading Factor Each Output	Propagation Delay tpd ns typ	Power Dissipation P <sub>D</sub> mW typ/pkg
	Type 1 -55 to +125°C	Type 1 0 to +75°C			
Dual 4-Channel Data Selector	MC4300F,L	MC4000F,L,P	10	Control Line = 18 Data Line = 11	150
BCD-to-Binary/Binary-to-BCD Number Converter		MC4001F,L,P	Open Collector $I_{OL} = 16 \text{ mA}$	Address Time <45 ns	300
Dual Data Distributor	MC4302F,L	MC4002F,L,P	10	10.5	175
16 Bit Scratch Pad Memory Cell	MC4304F,L	MC4004F,L,P	Open Collector $I_{OL} = 40 \text{ mA}$ $I_{OL} = 20 \text{ mA}$	Write mode 25 Sense mode 15	250
16 Bit scratch Pad Memory Cell	MC4305F,L	MC4005F,L,P		Write mode 25 Sense mode 15	250
Binary to One-of-Eight Line Decoder	MC4306F,L	MC4006F,L,P	10	14	100
Dual Binary to One-of-Four Line Decoder	MC4307F,L	MC4007F,L,P	10	14	125
8-Bit Parity Tree	MC4308F,L	MC4008F,L,P	10	15 to 30	150
Dual 4 Bit Parity Tree	MC4310F,L	MC4010F,L,P	10	9.5 to 22	125
4-Bit Shift Register	MC4312F,L	MC4012F,L,P	10	22/bit	180
Quad Type D Flip Flop	MC4315F,L	MC4015F,L,P	10	16	190
Programmable Module-N Decade Counter	MC4316F,L	MC4016F,L,P	8	Clock to Q3 = 50 Clock to Bus = 35	250
Programmable Modulo 2, Modulo 5 Counters	MC4317F,L	MC4017F,L,P	8	Clock to Q3 = 50 Clock to Bus = 35	250
Programmable Module-N Hexadecimal Counter	MC4318F,L	MC4018F,L,P	8	Clock to Q3 = 50 Clock to Bus = 35	250
Dual Programmable Modulo 4 Counters	MC4319F,L	MC4019F,L,P	8	Clock to Q3 = 50 Clock to Bus = 35	250

MC4300/4000 Series continued

Function	-55 to +125°C	0 to +75°C	Output Loading Factor Each Output	Propagation Delay $t_{pd}$ ns typ	Power Dissipation $P_D$ mW typ/pkg
Dual 4-Bit Comparator (Open Collector)	MC4321F,L	MC4021F,L,P	10	20	250
Dual 4-Bit Comparator	MC4322F,L	MC4022F,L,P	10	20	250
4-Bit Universal Counter	MC4323F,L	MC4023F,L,P	10	16/bit	200
Dual Voltage Controlled Multivibrator	MC4324F,L	MC4024F,L,P	7	$f_{max} = 30$ MHz	150
Full Adder	MC4326F,L	MC4026F,L,P	15/12**	25/13#	90
Full Adder	MC4327F,L	MC4027F,L,P	7/6**	25/13#	90
Adder (Dependent Carry)	MC4328F,L	MC4028F,L,P	15/12**	25/13#	125
Adder (Dependent Carry)	MC4329F,L	MC4029F,L,P	7/6**	25/13#	125
Adder (Independent Carry)	MC4330F,L	MC4030F,L,P	15/12**	25/13#	125
Adder (Independent Carry)	MC4331F,L	MC4031F,L,P	7/6**	25/13#	125
Carry Decoder	MC4332F,L	MC4032F,L,P	—	$\Delta t_{pd} = 4$ decoder	20
Quad Latch (Open Collector)	MC4335F,L	MC4035F,L,P	7	25	140
Quad Latch	MC4337F,L	MC4037F,L,P	10	25	150
Inverting/Non-Inverting One-of-Eight Decoder	—	MC4038F,L,P	Open Collector $I_{OL} = 20$ mA	Address Time <45 ns	240
Seven Segment Character Generator	—	MC4039F,L,P			240
Binary to Two-of-Eight Decoder	—	MC4040F,L,P			200
Single-Error Hamming Code Detector and Generator	—	MC4041F,L,P			240
Quad Predriver	MC4342F,L	MC4042F,L,P	$I_{OL} = 50$ mA Open Collector	15	120
Dual Line Selector	MC4343F,L	MC4043F,L,P	$I_{OL} = 400$ mA Pulsed	20	70
Phase-Frequency Detector	MC4344F,L	MC4044F,L,P	10	9.0	85
Non-Inverting One-of-Eight Decoder	—	MC4048F,L,P	Open Collector $I_{OL} = 16$ mA	Address Time <50 ns)	240
Counter-Latch-Decoder	MC4350F,L	MC4050F,L,P	Open Collector $I_{OL} = 40$ mA	$f_{Tog} = 35$ MHz	450
Counter-Latch-Decoder	MC4351F,L	MC4051F,L,P	Open Emitter 40 mA Sourcing Capability @ 10% Duty Cycle	$f_{Tog} = 35$ MHz	450
Dual Decade Counter	MC4352F,L	MC4052F,L,P	10	$f_{Tog} = 40$ MHz	350
Dual Hexadecimal Counter	MC4353F,L	MC4053F,L,P	10	$f_{Tog} = 40$ MHz	350
Dual Decade Up/Down Counter	MC4354F,L	MC4054F,L,P	10	$f_{Tog} = 12$ MHz	600
Dual Binary Up/Down Counter	MC4355F,L	MC4055F,L,P	10	$f_{Tog} = 12$ MHz	600
NBCD Adder	MC4356F,L	MC4056F,L,P	10	30	300
Nines Complement/Zero Element	MC4358F,L	MC4058F,L,P	10	30	200
Bus Transfer Switch	MC4360F,L	MC4060F,L,P	10	25	350
Dual Majority Logic Gate	MC4362F,L	MC4062F,L,P	10	Z = 20 Z = 11	75
64-Bit Random Access Memory	—	MC4064F,L,P	Open Collector $I_{OL} = 15$ mA	Access Time <60 ns	384
Dual MOS-to-TTL Level Translator with Tri-state Output	MC4368F,L	MC4068F,L,P	10	20	150

\* MC4300/MC400 Series loading specified for use with MTTLI Devices

#Add delay, Carry delay

**DUAL 4-CHANNEL  
DATA SELECTOR**

**MC4300  
MC4000**

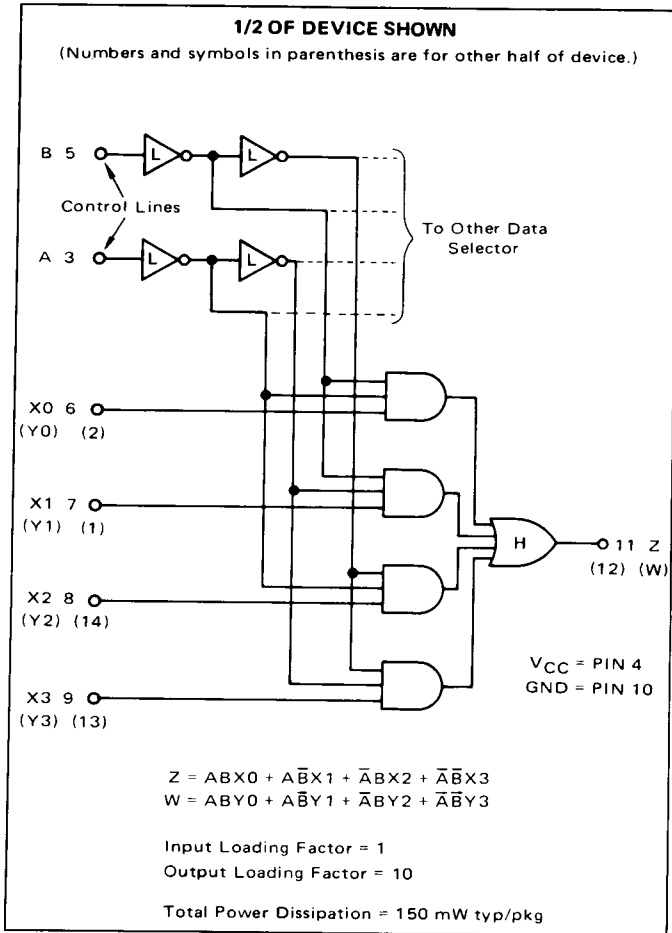

This device consists of two four-channel data selectors with common control lines, constructed from high-level AND-OR gates and low-level inverters. By selecting one of four logic combinations, information on one of the four data inputs will be routed to the output.

Data selectors are useful in applications where digital data is to be routed from one of several registers or locations to another register or location for processing.

**TYPICAL PROPAGATION DELAY TIMES (ns)**  
T<sub>A</sub> = 25°C

INPUT	Z	CONDITIONS
A	18	X0 = X2 = X3 = logic "0", X1 =
B	15	logic "1". A and B are defined by the logic equations.
X1	11	

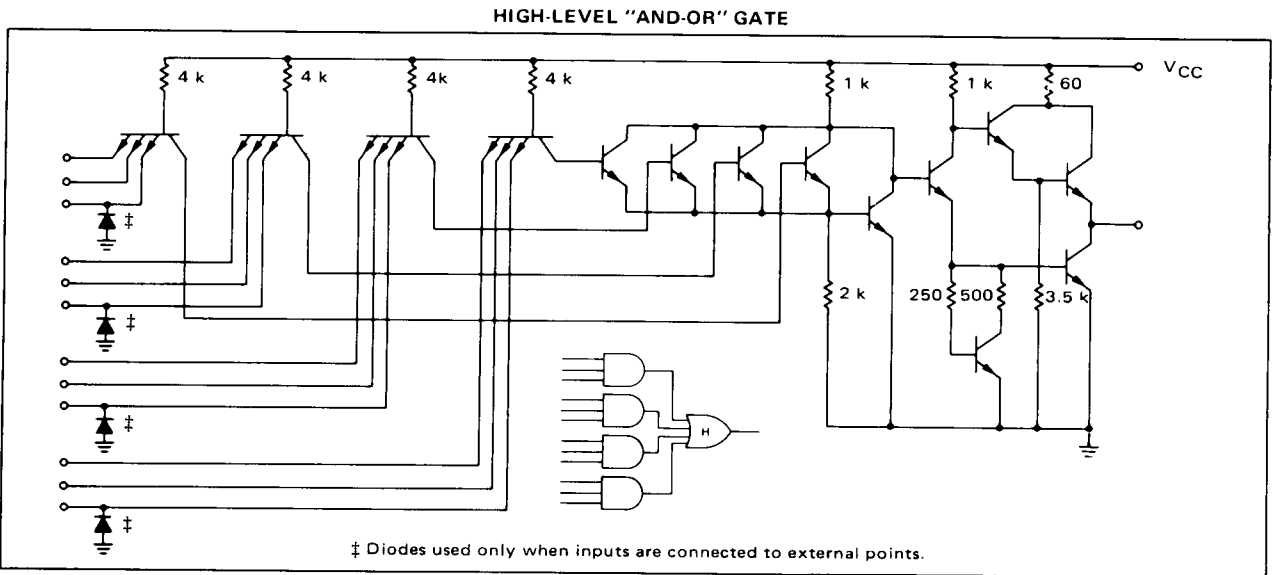
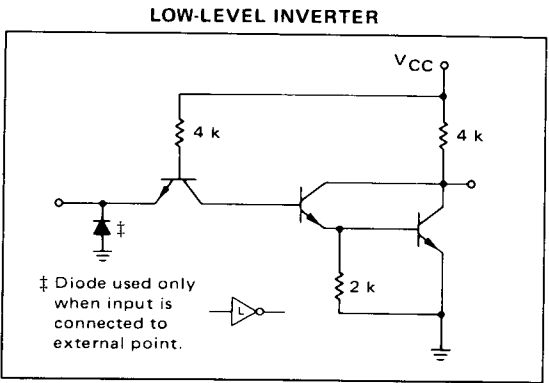

BCD-TO-BINARY/  
BINARY-TO-BCD  
NUMBER CONVERTER

**MC4301**

**MC4001**

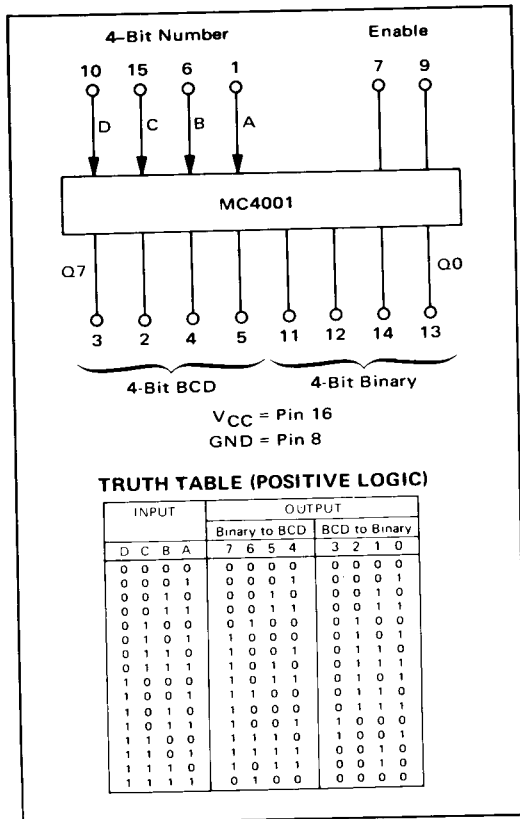

The MC4301/4001 serves as a basic building block in Binary-to-BCD and BCD- to-Binary converters. Conversion of any length binary or BCD word can be accomplished by interconnecting MC4001 packages. The MC4001 also contains a full adder and subtractor.

**Features:**

- Address times < 45 ns
- Outputs sink 16 mA
- Output capacitance < 7.0 pF @ 1.5 V

**ENABLE INPUT TRUTH TABLE (POSITIVE LOGIC)**

E	E	Q7	Q6	Q5	Q4	Q3	Q2	Q1	Q0
0	0	1	1	1	1	1	1	1	1
0	1	1	1	1	1	1	1	1	1
1	0	1	1	1	1	1	1	1	1
1	1	FUNCTION ENABLED							

**"NAND" GATE EQUIVALENT OF BCD-TO-BINARY CONVERTER**

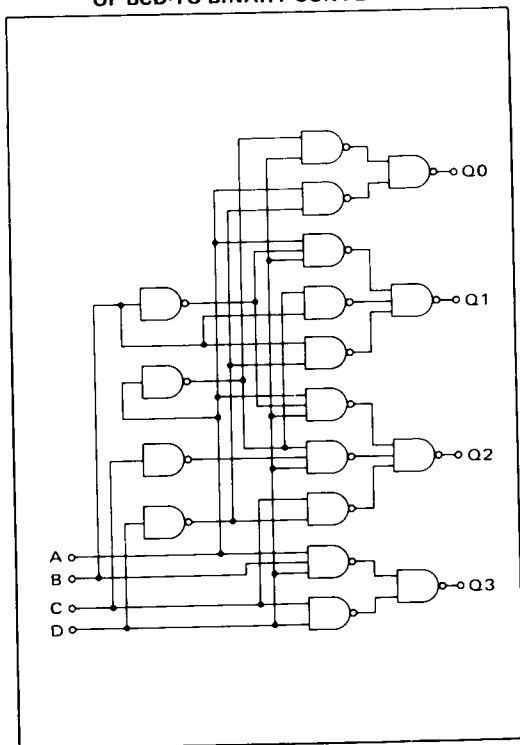

**"NAND" GATE EQUIVALENT OF BINARY-TO-BCD CONVERTER**

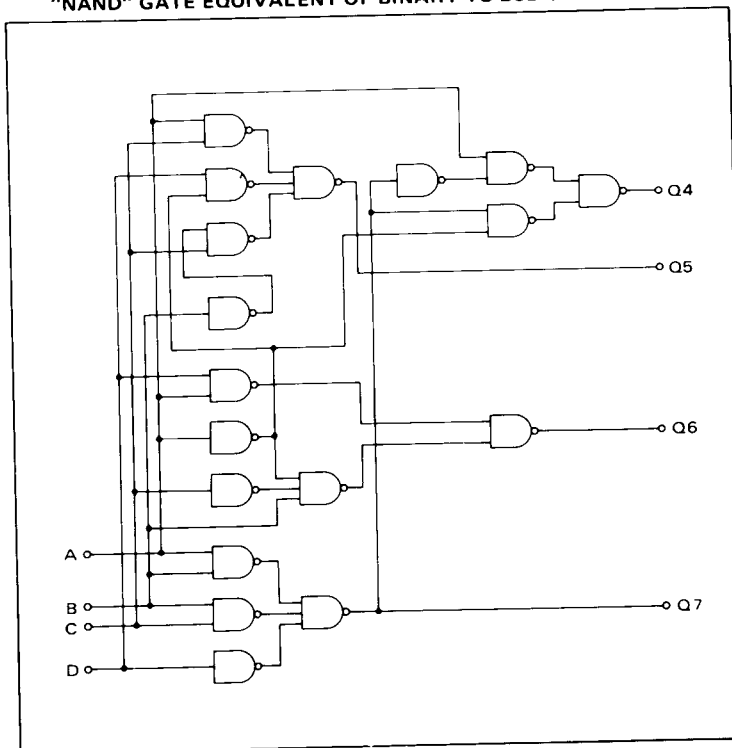

**DUAL DATA  
DISTRIBUTOR  
MC4302  
MC4002**

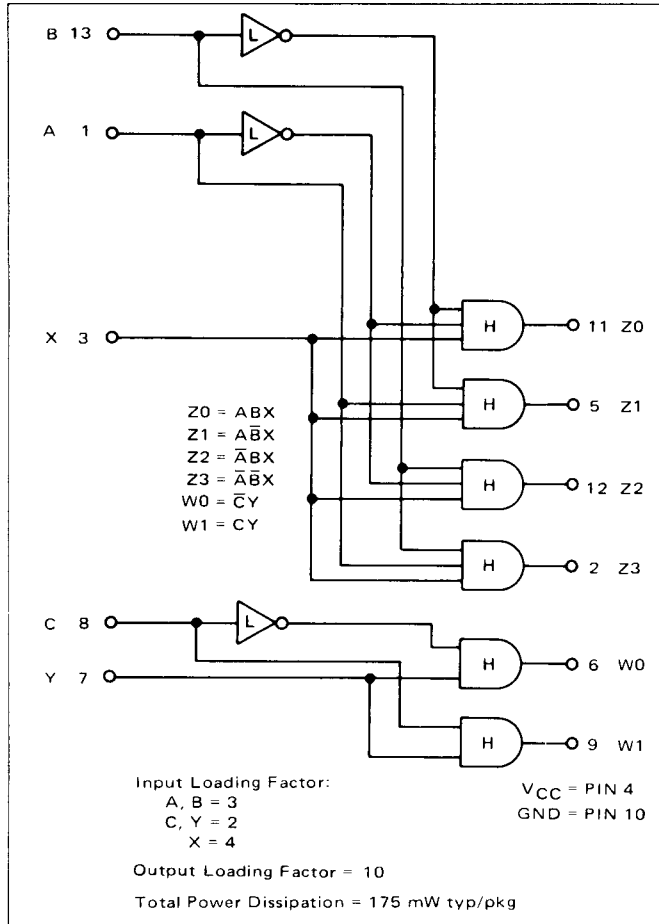

This device consists of two data distributors constructed from high-level AND gates and low-level inverters. One distributes information present at the input line to one of four output lines; the other distributes information present at the input to one of two output lines. The routing path is selected by the logic signals at the control lines A, B or C.

Data distributors are useful in applications where digital data is to be routed from a single register or location to one of several registers or locations for processing.

**TYPICAL PROPAGATION DELAY TIMES (ns)**  
 $T_A = 25^\circ\text{C}$

INPUT	Z0	Z1	Z2	Z3
A	14.5	10.5	14.5	10.5
B	14.5	14.5	10.5	10.5
X	10.5	10.5	10.5	10.5

INPUT	W0	W1
C	14.5	10.5
Y	10.5	10.5

**LOW-LEVEL INVERTER**

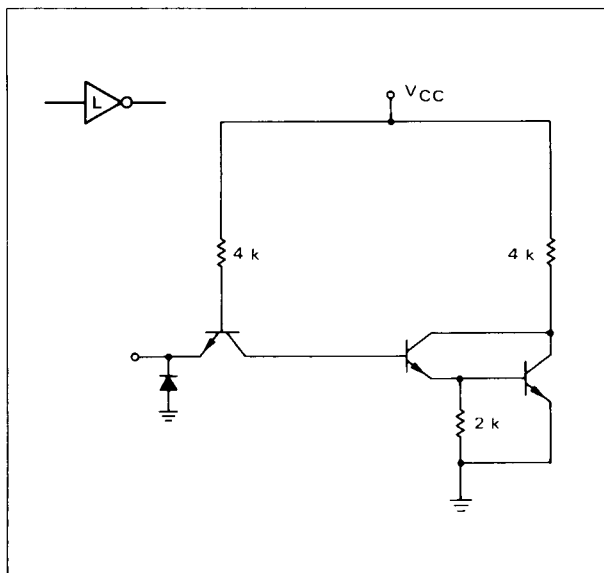

**HIGH-LEVEL "AND" GATE**

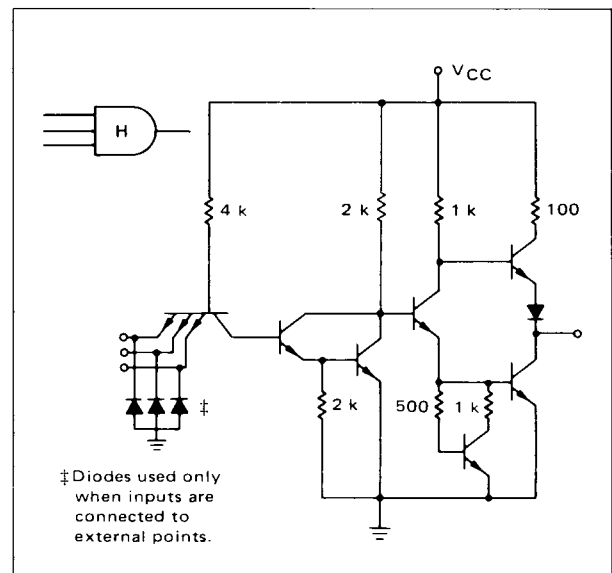

16-BIT SCRATCH PAD  
MEMORY CELL

MC4304 • MC4305  
MC4004 • MC4005

This 16-Bit memory cell serves as the basic building block for scratch pad memory systems having cycle times of less than 100 ns. The basic cell provides 16 words of one-bit memory operating in the non-destructive readout (NDRO) mode.

The memory contains 16 flip-flops arranged in a four-by-four matrix. A single bit of the matrix is selected by

driving one of four X select lines and one of four Y select lines above the select threshold. Two sense amplifiers are shared by all 16 bits and provide a double rail output from the selected bit. The sense output of many devices can be "wired ORed" together since the output stage does not have a pullup resistor or network. Two write amplifiers allow a "1" or a "0" to be written into a selected bit.

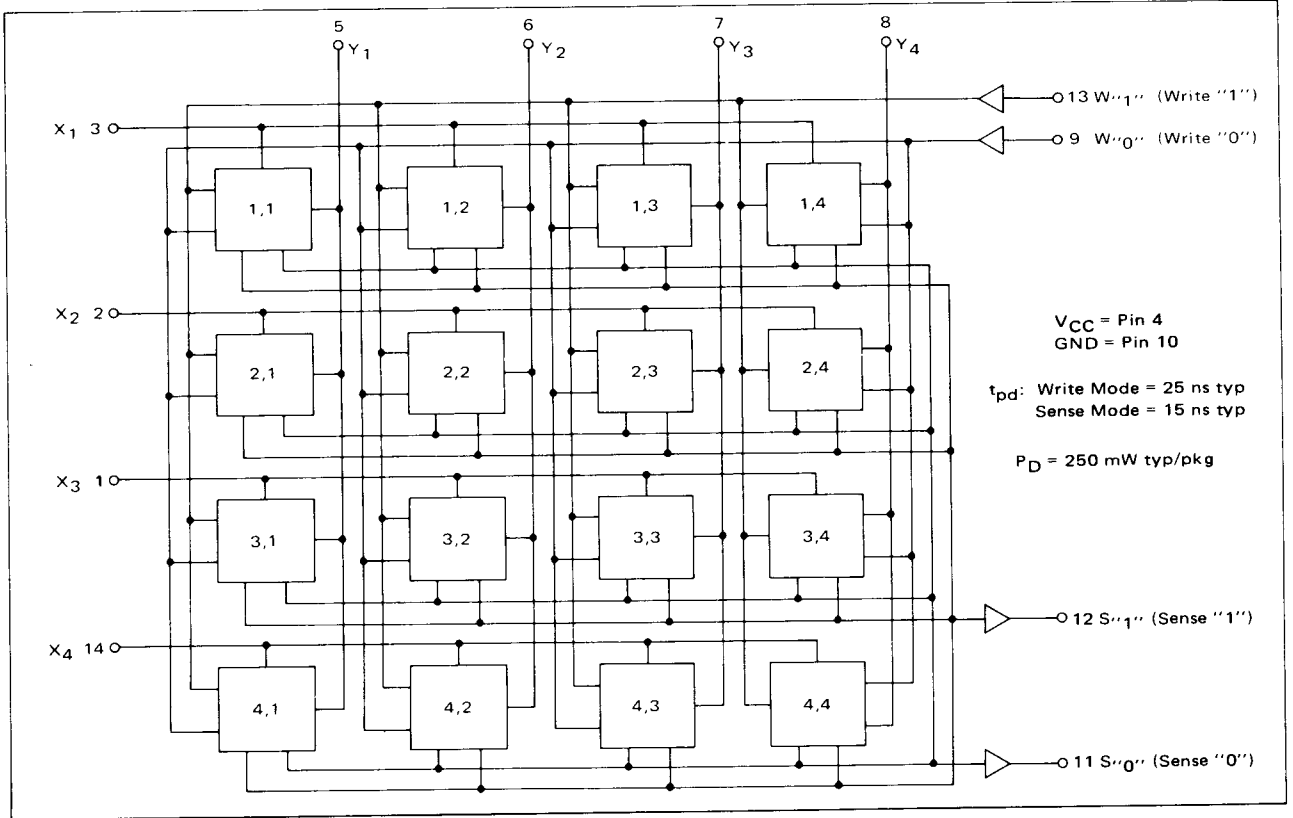

— OPERATING SEQUENCE —

FIGURE 1 — READ MODE TIMING DIAGRAM

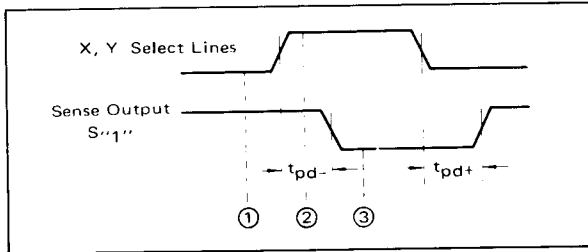

- ① All X and Y selection lines and both write inputs are low (less than +0.8 V).
- ② Desired bit selected by driving the appropriate X and Y select lines more positive than +2.1 V.
- ③ After the turn-on delay time ( $t_{pd-}$ ), the S'1' output will be low (less than +0.45 V) and the S'0' output will be high (more than +2.5 V), providing that a "1" is stored in the selected bit.

FIGURE 2 — WRITE MODE TIMING DIAGRAM

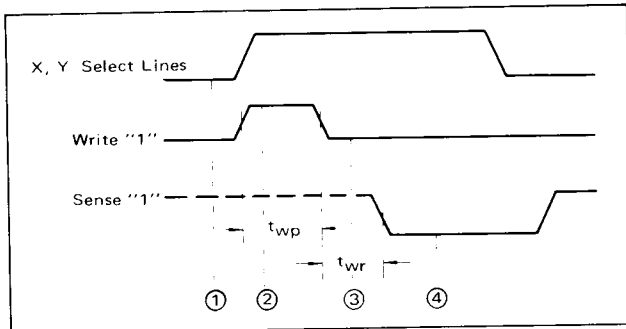

- ① All X and Y selection lines and both write inputs are low (less than +0.8 V).
- ② Bit location selected by driving the appropriate X and Y select lines more positive than +2.1 V. To write a "1", drive the write "1" input more positive than +2.1 V for a minimum time of 25 ns ( $t_{wp}$ ).
- ③ Write "1" line returned to low state.
- ④ The stored bit can be read after the write recovery time ( $t_{wr}$ ) of 40 ns. (The sense output is in an indeterminate state between steps 2 and 4.)

**BINARY TO ONE-OF-EIGHT  
LINE DECODER**

**MC4306  
MC4006**

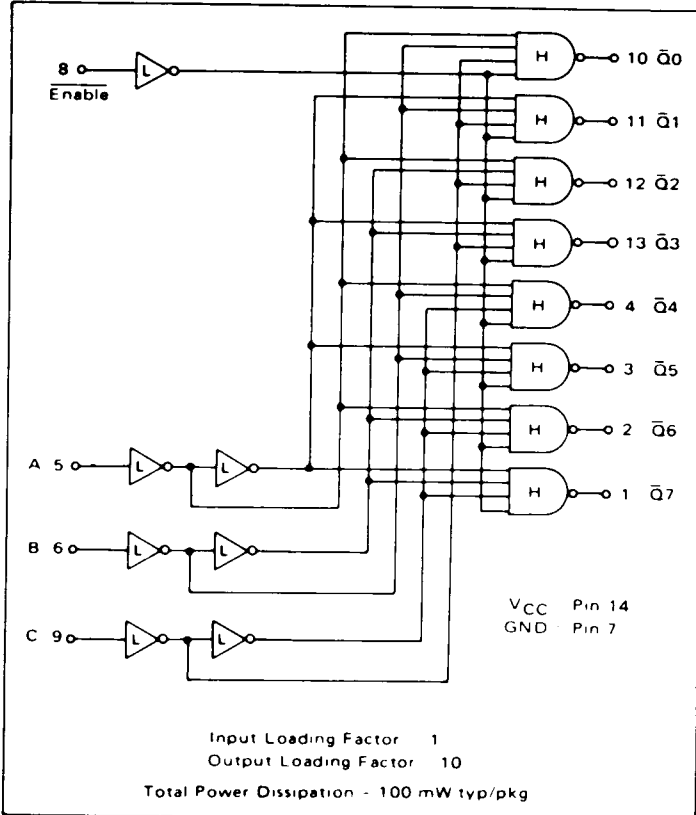

**LOW-LEVEL INVERTER**

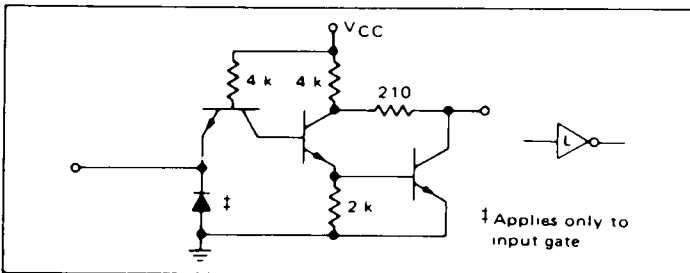

**HIGH-LEVEL GATE**

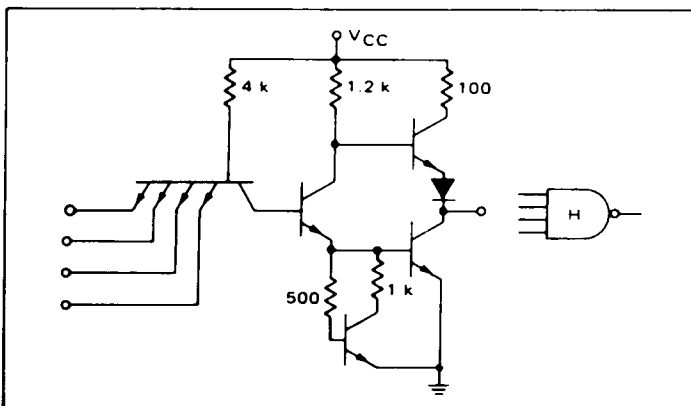

This device converts three lines of input data to a one-of-eight output. The enable line provides an inhibit capability and also allows the decoder to be expanded for larger decoder systems.

The 3-input/8-output decoder consists of high-level and low-level gates internally connected for minimum power consumption and maximum driving capabilities. The enable gate must be in the low state to perform the decode operation shown in the truth table.

The propagation delays shown in the charts are typical and vary according to loading, interconnection wiring length, and the number of logic levels involved.

TRUTH TABLE

$\bar{E}$	0	1	2	3	4	5	6	7	8
0	0	0	1	1	1	1	1	1	0
0	0	1	1	1	1	1	1	0	1
0	1	0	1	1	1	1	0	1	1
0	1	1	1	1	1	0	1	1	1
1	0	0	1	1	1	0	1	1	1
1	0	1	1	1	0	1	1	1	1
1	1	0	1	0	1	1	1	1	1
1	1	1	0	1	1	1	1	1	1

1 High State  
0 Low State

**TYPICAL TURN-ON DELAY TIMES (ns)**  
 $T_A = 25^\circ\text{C}, C_T = 25 \text{ pF}$

INPUT	$\bar{Q}0$	$\bar{Q}1$	$\bar{Q}2$	$\bar{Q}3$	$\bar{Q}4$	$\bar{Q}5$	$\bar{Q}6$	$\bar{Q}7$
A	11.5	16.0	11.5	16.0	11.5	16.0	11.5	16.0
B	11.5	11.5	16.0	16.0	11.5	11.5	16.0	16.0
C	11.5	11.5	11.5	11.5	16.0	16.0	16.0	16.0
$\bar{E}$	13.5	13.5	13.5	13.5	13.5	13.5	13.5	13.5

**TYPICAL TURN-OFF DELAY TIMES (ns)**  
 $T_A = 25^\circ\text{C}, C_T = 25 \text{ pF}$

INPUT	$\bar{Q}0$	$\bar{Q}1$	$\bar{Q}2$	$\bar{Q}3$	$\bar{Q}4$	$\bar{Q}5$	$\bar{Q}6$	$\bar{Q}7$
A	14.0	19.5	14.0	19.5	14.0	19.5	14.0	19.5
B	14.0	14.0	19.5	19.5	14.0	14.0	19.5	19.5
C	14.0	14.0	14.0	14.0	19.5	19.5	19.5	19.5
$\bar{E}$	14.5	14.5	14.5	14.5	14.5	14.5	14.5	14.5

DUAL BINARY TO  
ONE-OF-FOUR LINE DECODER

MC4307  
MC4007

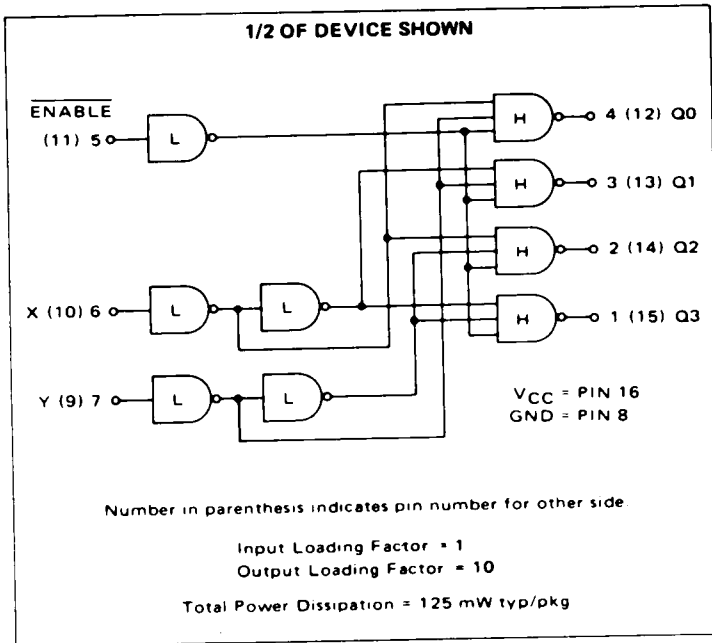

This device converts two lines of input data to a one-of-four output. The enable line provides an inhibit capability and also allows the decoder to be expanded for larger decoder systems.

The dual 2-input/4-output decoder consists of high-level and low-level gates internally connected for minimum power consumption and maximum driving capabilities. The enable gate must be in the low state to perform the decode operation shown in the truth table.

The propagation delays shown in the charts are typical and vary according to loading, interconnection wiring length, and the number of logic levels involved.

TRUTH TABLE

E = 0

X	Y	Q0	Q1	Q2	Q3
0	0	0	1	1	1
1	0	1	0	1	1
0	1	1	1	0	1
1	1	1	1	1	0

1 = High State  
0 = Low State

LOW-LEVEL GATE

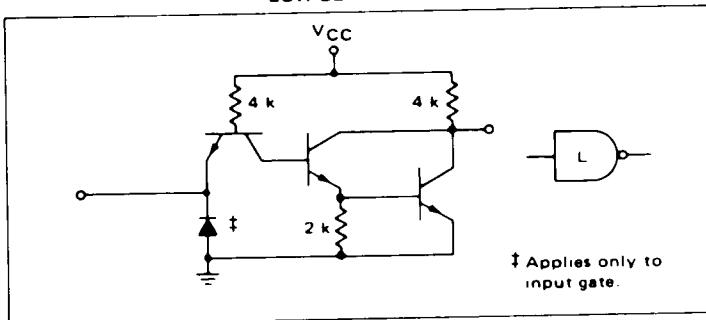

HIGH-LEVEL GATE

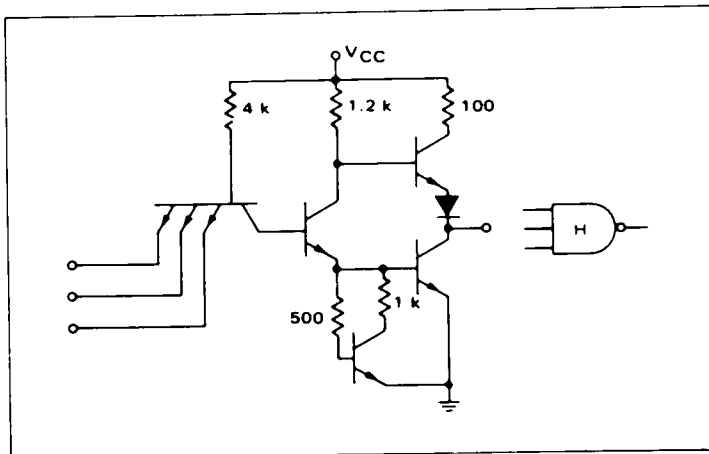

TYPICAL TURN-ON DELAY TIMES (ns)  
TA = 25°C

Input	Q0	Q1	Q2	Q3
X	11.5	15.5	11.5	15.5
Y	11.5	11.5	15.5	15.5
$\bar{E}$	13.5	13.5	13.5	13.5

TYPICAL TURN-OFF DELAY TIMES (ns)  
TA = 25°C

Input	Q0	Q1	Q2	Q3
X	14.0	19.0	14.0	19.0
Y	14.0	14.0	19.0	19.0
$\bar{E}$	14.5	14.5	14.5	14.5



# 8-BIT PARITY TREE

## MC4308 MC4008

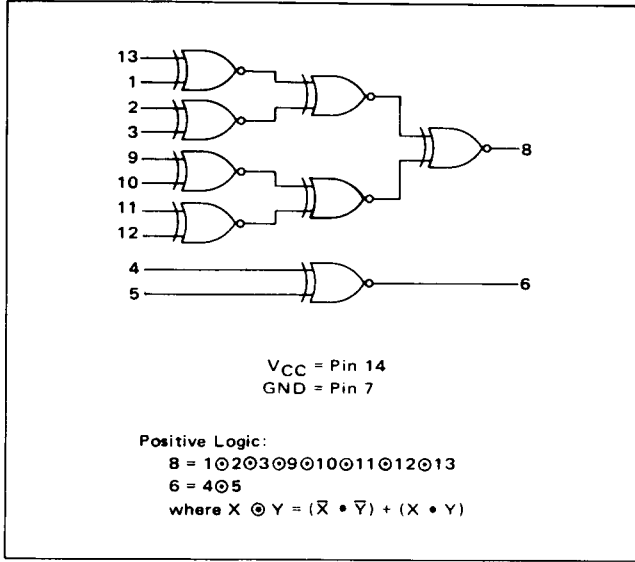

This device consists of seven Exclusive NOR gates connected to check even parity. The output will be in the logic "1" state as long as the "1" state is present on an even number of inputs. The additional Exclusive NOR gate can be used to connect two 8-bit parity trees to form a 16-bit parity tree, or it can be used to convert the parity tree to check odd parity by connecting one gate input to the output of the parity tree and grounding the other input. This conversion can also be accomplished by connecting a simple inverter to the output of the parity tree.

Input Loading Factor = 2  
Output Loading Factor = 10

Total Power Dissipation = 150 mW typ/pkg  
Propagation Delay Time = 15-30 ns typ

### TYPICAL PROPAGATION DELAY TIMES

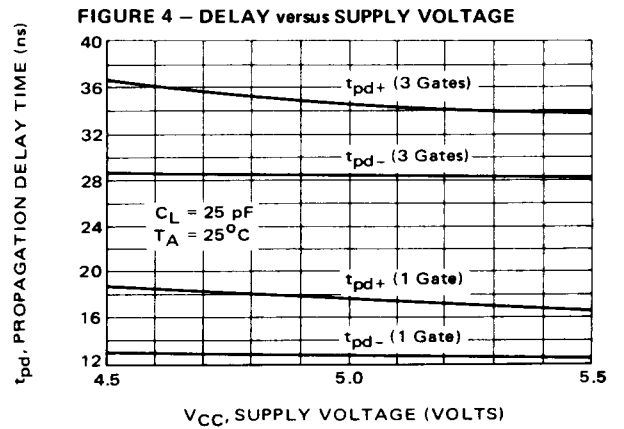
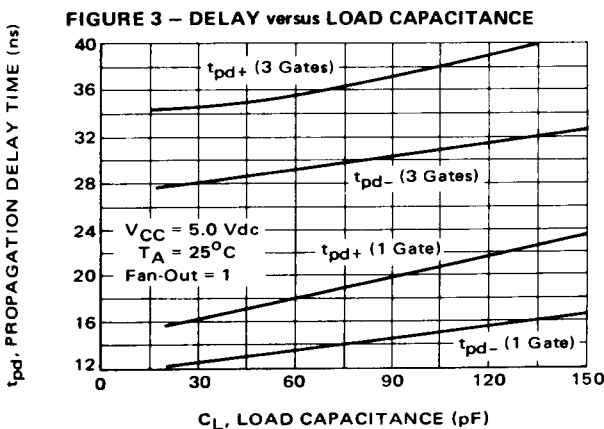
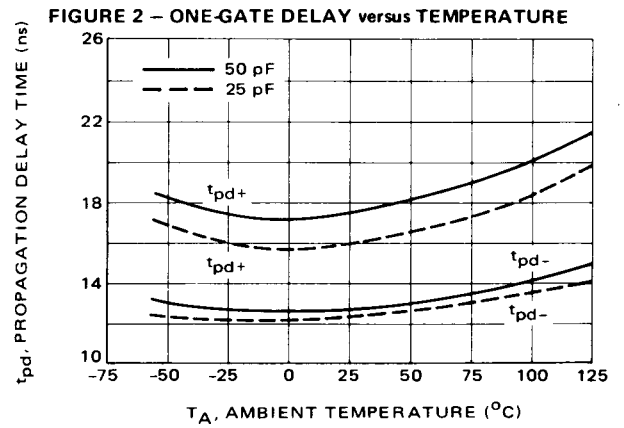
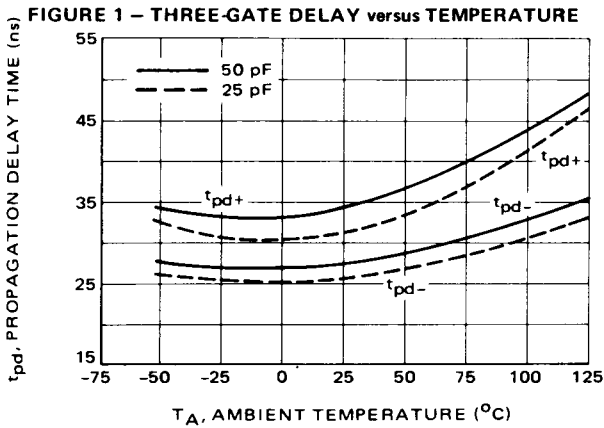

DUAL 4-BIT PARITY TREE

MC4310  
MC4010

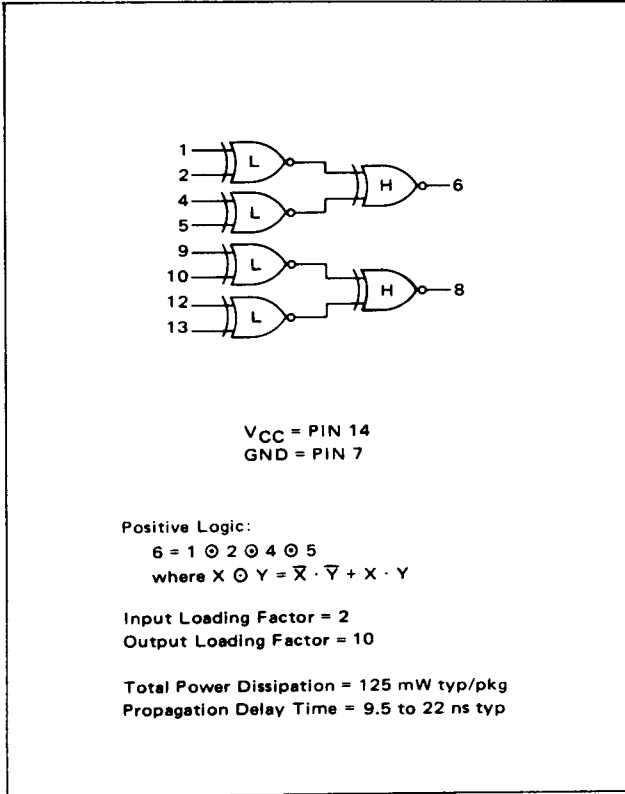

Three Exclusive NOR gates are connected together to form each of the two 4-bit parity trees in the package. An even number of logic "1" states on the inputs will result in a logic "1" output state. An odd parity checker can be made by connecting an inverter to the output of the device.

This function is constructed using low and high-level Exclusive NOR gates connected as shown in the logic diagram to maximize output drive capability and minimize power dissipation.

LOW-LEVEL GATE

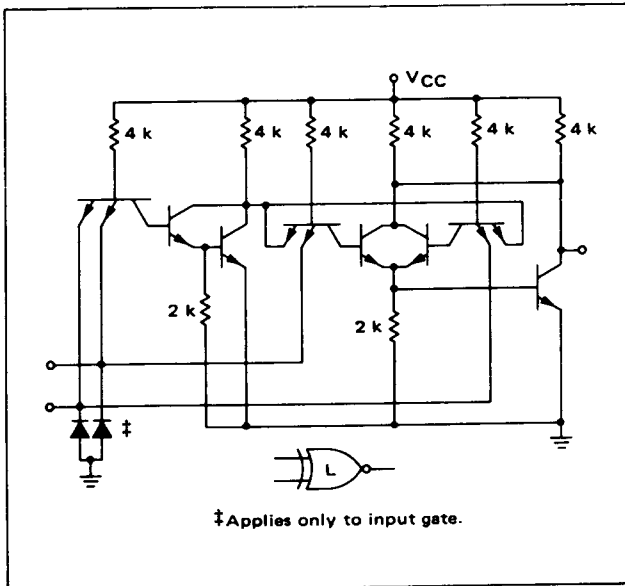

HIGH-LEVEL GATE

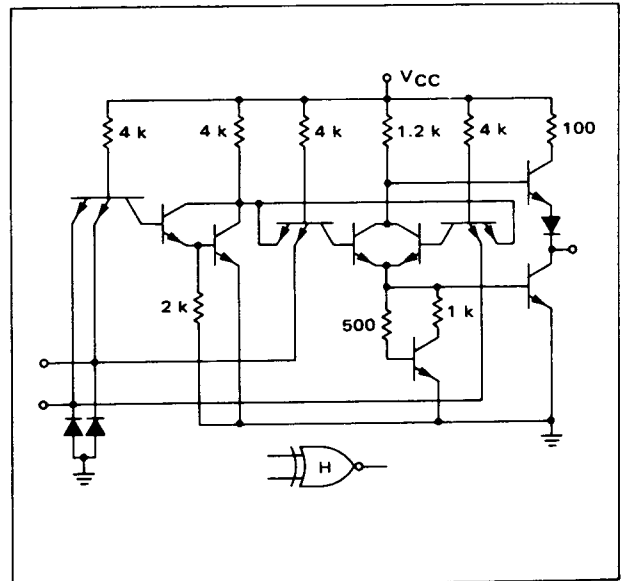

4-BIT SHIFT REGISTER

MC4312  
MC4012

This 4-bit register provides parallel or serial data entry and retrieval, determined by the logic state of the mode control input. For parallel operation, set the mode control to the logic "1" state and strobe the information at the Dp inputs into the register. Serial left-shift operation is achieved in this mode by connecting the Q outputs to the Dp inputs of the previous stage. Serial right-shift operation, set the mode control to logic "0" and clock data into the register from D<sub>S</sub>.

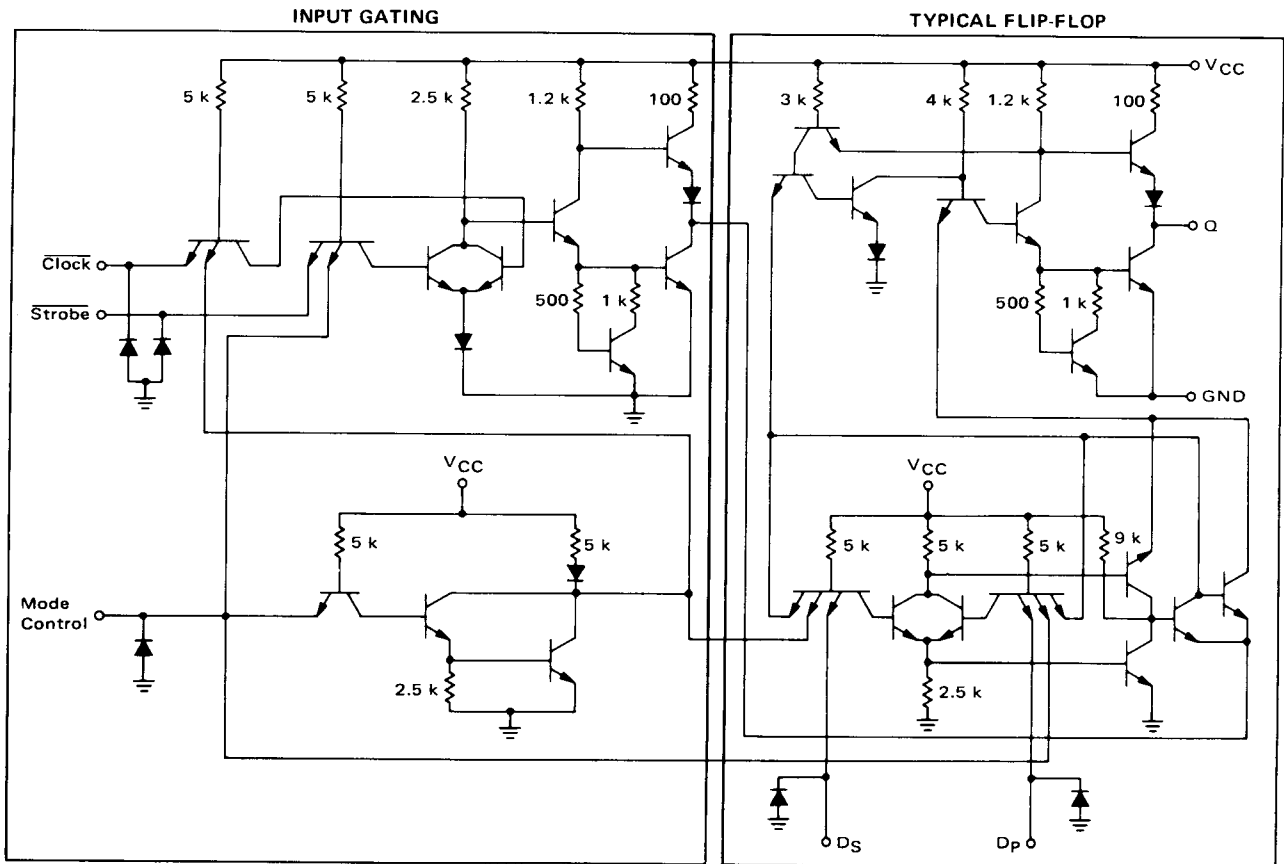
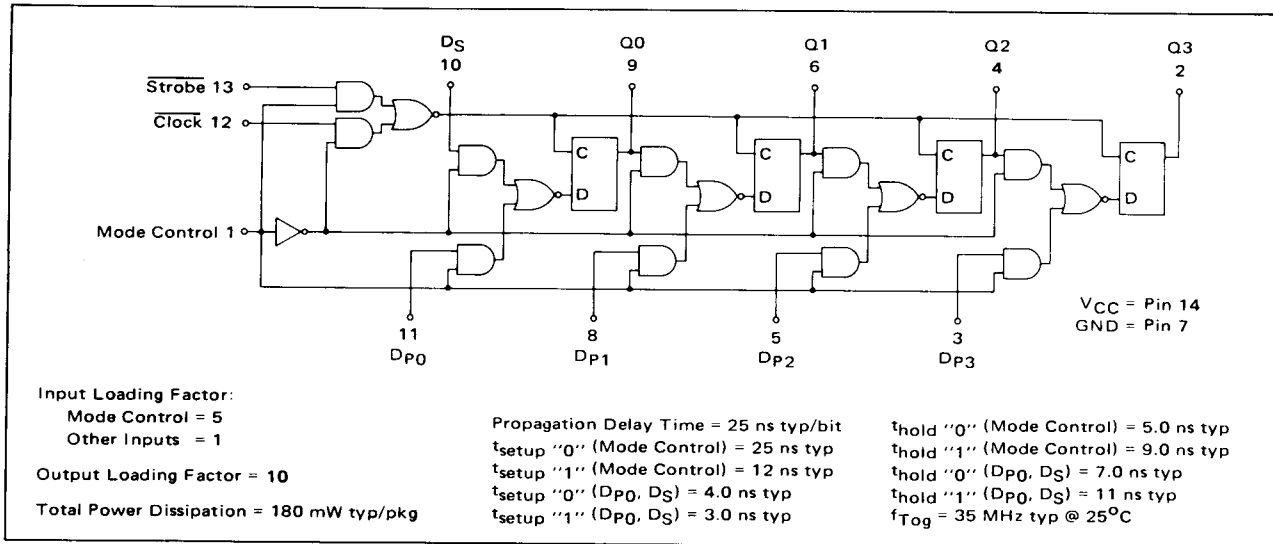

QUAD TYPE D FLIP-FLOP

MC4315  
MC4015

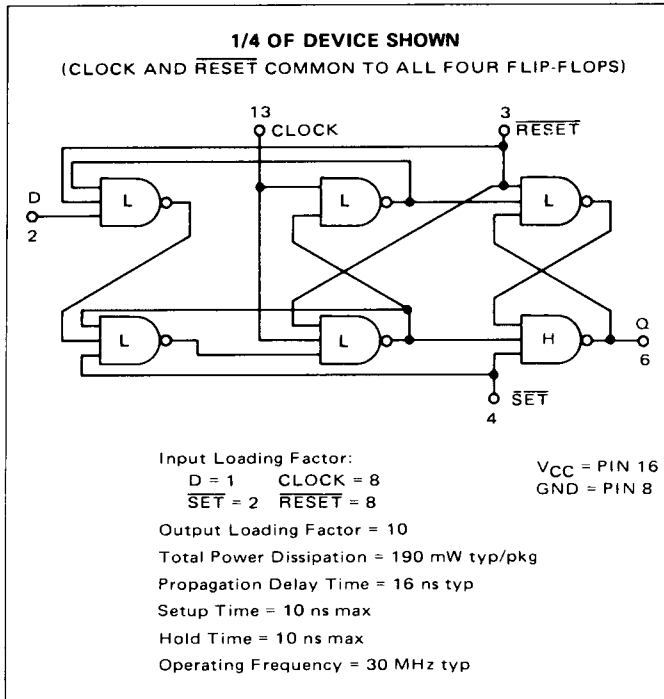

LOW-LEVEL GATE

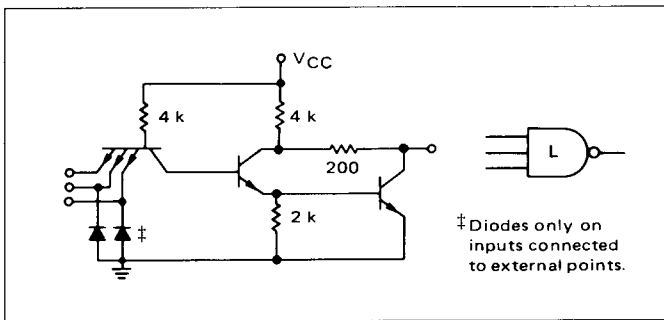

HIGH-LEVEL GATE

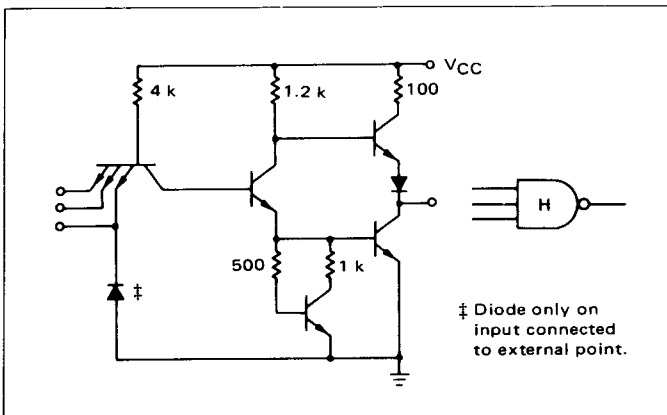

This quad type D flip-flop triggers on the positive edge of the clock input. During the clock transition the state of the D input is transferred to the Q output. The device is useful in shift registers and simple counters.

Power dissipation is minimized and output drive capability is maximized by connecting low and high-level gates as shown by the logic diagram to form each of the four flip-flops.

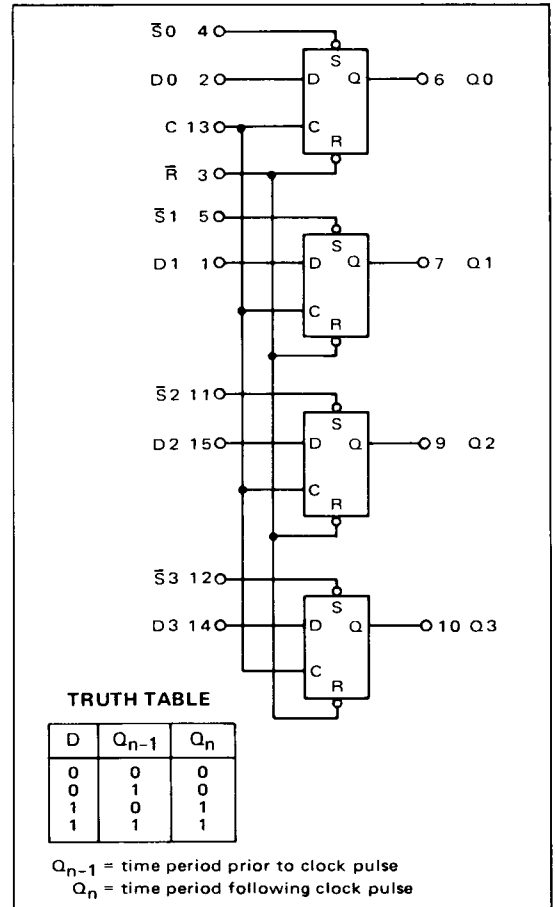

OPERATING CHARACTERISTICS

Data must be present at the D input 10 ns prior to the rise of the clock, and remain 10 ns after the clock signal rises. Data may be changed any time during the clock cycle except the interval between the setup time (10 ns) and the hold time (10 ns) without affecting the operation of the flip-flop. The data input is inhibited when the clock is high. When the clock is in the low state, the input steering section continually reflects the state of the D input. Information present at the D input during the time interval between the setup and hold times is transferred to the bistable section on the positive edge of the clock, and outputs Q and  $\bar{Q}$  respond accordingly.

The flip-flops can be set or reset directly at any time, regardless of the state of the clock, by applying a low state to the direct Set or Reset inputs.

PROGRAMMABLE MODULO-N  
COUNTERS

**MC4316 MC4016**  
**MC4317 MC4017**  
**MC4318 MC4018**  
**MC4319 MC4019**

The monolithic devices are programmable, cascadable, modulo-N-counters. The MC4316/4016 can be programmed to divide by any number (N) from 0 thru 9, the MC4318/4018 from 0 thru 15. The MC4317/4017 consists of a modulo 2 counter which can be programmed to divide by 0 or 1 and a modulo 5 counter which can be programmed to divide by any number from 0 to 4. The MC4319/4019 contains two modulo 4 counters which can be programmed to divide by any number from 0 to 3.

The parallel enable (PE) input enables the parallel data inputs D0 thru D3. All zeros are entered into the counter by applying a logic "0" level to the master reset (MR) and PE inputs. This causes the counter to stop counting (count = 0). All data inputs are independent of the logic level of the Clock.

Modulo-N counters are useful in frequency synthesizers, in phase-locked loops, and in other applications where a simple method for frequency division is needed.

All Types:

Input Loading Factor:      Total Power Dissipation =  
Clock,  $\overline{PE}$  = 2                      250 mW typ/pkg  
D0, D1, D2, D3, Gate = 1      Propagation Delay Time:  
 $\overline{MR}$  = 4                                  Clock to Q3 = 50 ns typ  
Output Loading Factor = 8            Clock to Bus = 35 ns typ

**MC4316/4016**  
**MC4318/4018**

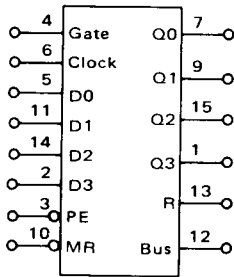

V<sub>CC</sub> = Pin 16  
Gnd = Pin 8

**MC4317/4017**  
**MC4319/4019**

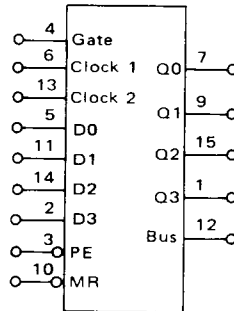

V<sub>CC</sub> = Pin 16  
Gnd = Pin 8

**MC4318/4018**

COUNT	OUTPUT			
	Q3	Q2	Q1	Q0
15	1	1	1	1
14	1	1	1	0
13	1	1	0	1
12	1	1	0	0
11	1	0	1	1
10	1	0	1	0
9	1	0	0	1
8	1	0	0	0
7	0	1	1	1
6	0	1	1	0
5	0	1	0	1
4	0	1	0	0
3	0	0	1	1
2	0	0	1	0
1	0	0	0	1
0	0	0	0	0

**MC4316/4016**

COUNT	OUTPUT			
	Q3	Q2	Q1	Q0
9	1	0	0	1
8	1	0	0	0
7	0	1	1	1
6	0	1	1	0
5	0	1	0	1
4	0	1	0	0
3	0	0	1	1
2	0	0	1	0
1	0	0	0	1
0	0	0	0	0

**MC4317/4017**

COUNT	OUTPUT
	Q0
1	1
0	0

**MC4319/4019**

COUNT	OUTPUT	
	Q1	Q0
3	1	1
2	1	0
1	0	1
0	0	0

COUNT	OUTPUT		
	Q3	Q2	Q1
4	1	0	0
3	0	1	1
2	0	1	0
1	0	0	1
0	0	0	0

COUNT	OUTPUT	
	Q3	Q2
3	1	1
2	1	0
1	0	1
0	0	0

**OPERATING CHARACTERISTICS**

Basic operation of the MC4316/4016 and MC4318/4018 is the same. When operated as single stages, the Gate and Clock inputs must be tied together. The internal pullup resistor must be connected to the Buss node (pin 13 to pin 12). The programmable counter is set to count down by a pre-determined number (N) before recycling, according to the binary code present at the parallel preset inputs, P0 thru P3 (see the truth table). The binary information at inputs P0 thru P3 is preset into the counter after applying a logic "0" to the  $\overline{PE}$  input. Data may be entered synchronously or asynchronously while  $\overline{PE}$  is low, or when outputs Q0, Q1, Q2 and Q3 are in the logic "0" state and the Clock is low.

The counters may be set to divide by 10 (MC4316/4016) or 16 (MC4318/4018) regardless of preset input states by applying a logic "0" to the Buss node. This, in effect, disables the preset inputs and

causes a logic "0" to appear at the preset of each flip-flop of the counter. If a binary number greater than nine (1001) is applied to the preset inputs of the MC4316/4016, the counter will ignore the most significant bit and recognize only the three least significant bits.

**Cascading of Counters**

To cascade counters (Figure 1):

1. Connect Gate inputs of all stages to the Clock of the first stage.
2. Connect all Buss outputs to one common pullup resistor (2.0 kilohms, internal).
3. Connect the Clock input of each stage after the first stage to the Q3 output of the previous stage.
4. Take the divide-by-N pulse from the Buss outputs.

When cascaded, the count mode of the entire string of counters is defined by:

$$N = N_0 + 10 N_1 + 100 N_2 + \dots \text{ (MC4316/4016)}$$

$$\text{or } N = N_0 + 16 N_1 + 256 N_2 + \dots \text{ (MC4318/4018)}$$

where  $N_0, N_1, N_2, \dots$  are the BCD or binary numbers programmed at the zero, first, second, ... stages.

**LOGIC DIAGRAMS**

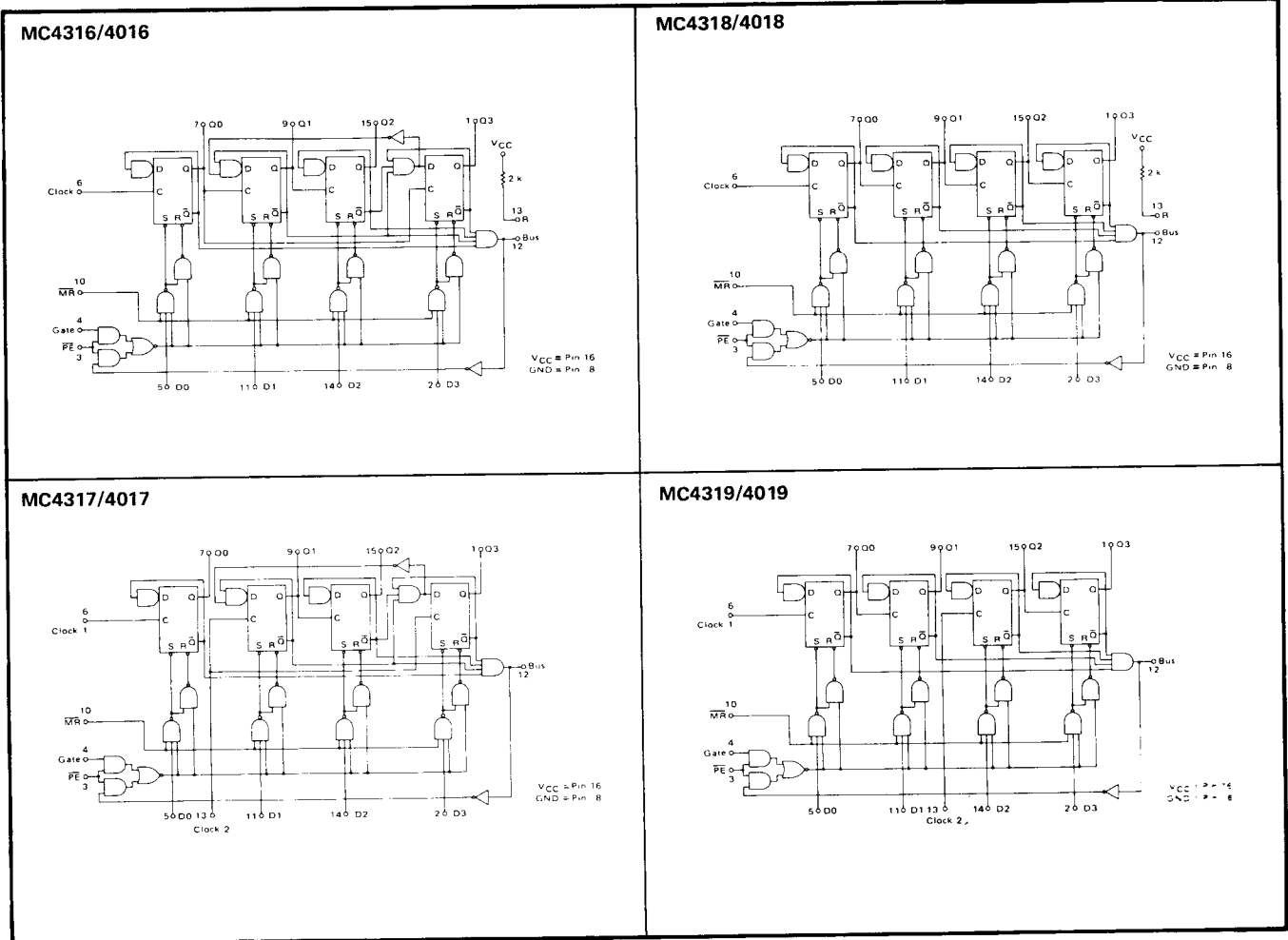

DUAL 4-BIT COMPARATOR

**MC4321/4021**  
**MC4322/4022**

The 4-bit comparator compares four bits of input information to four bits of reference information. When each bit of the input information is the same as its corresponding reference information, bit for bit, the output of the comparator will be in the high ("1") state. For any other condition, the output of the comparator will be in the low ("0") state.

In this dual 4-bit comparator, the four reference inputs (R) serve both comparators. There is no interrelation between the A and B data inputs of the dual comparator. Output Z1 reflects comparison of the A and R bits, while output Z2 shows conditions at inputs B and R.

The MC4021 has open-collector outputs; the MC4022 has totem-pole outputs.

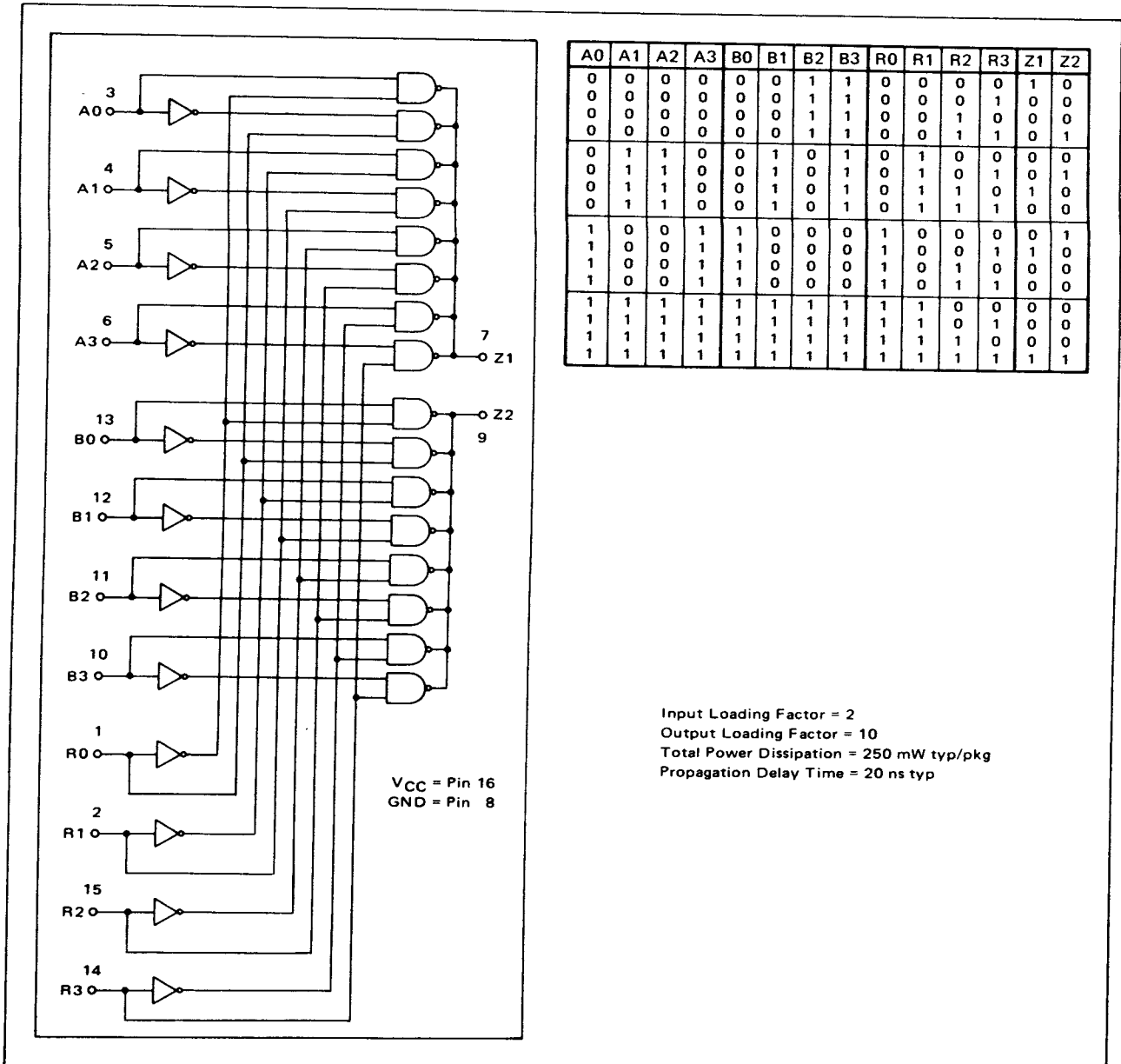

A0	A1	A2	A3	B0	B1	B2	B3	R0	R1	R2	R3	Z1	Z2
0	0	0	0	0	0	1	1	0	0	0	0	1	0
0	0	0	0	0	0	1	1	0	0	0	1	0	0
0	0	0	0	0	0	1	1	0	0	1	0	0	0
0	0	0	0	0	0	1	1	0	0	1	1	0	1
0	1	1	0	0	1	0	1	0	1	0	0	0	0
0	1	1	0	0	1	0	1	0	1	0	1	0	1
0	1	1	0	0	1	0	1	0	1	1	0	1	0
0	1	1	0	0	1	0	1	0	1	1	1	0	0
1	0	0	1	1	0	0	0	1	0	0	0	0	1
1	0	0	1	1	0	0	0	1	0	0	1	1	0
1	0	0	1	1	0	0	0	1	0	1	0	0	0
1	0	0	1	1	0	0	0	1	0	1	1	0	0
1	1	1	1	1	1	1	1	1	1	0	0	0	0
1	1	1	1	1	1	1	1	1	1	0	1	0	0
1	1	1	1	1	1	1	1	1	1	1	0	0	0
1	1	1	1	1	1	1	1	1	1	1	1	1	1

Input Loading Factor = 2  
Output Loading Factor = 10  
Total Power Dissipation = 250 mW typ/pkg  
Propagation Delay Time = 20 ns typ

4-BIT UNIVERSAL COUNTER

**MC4323**  
**MC4023**

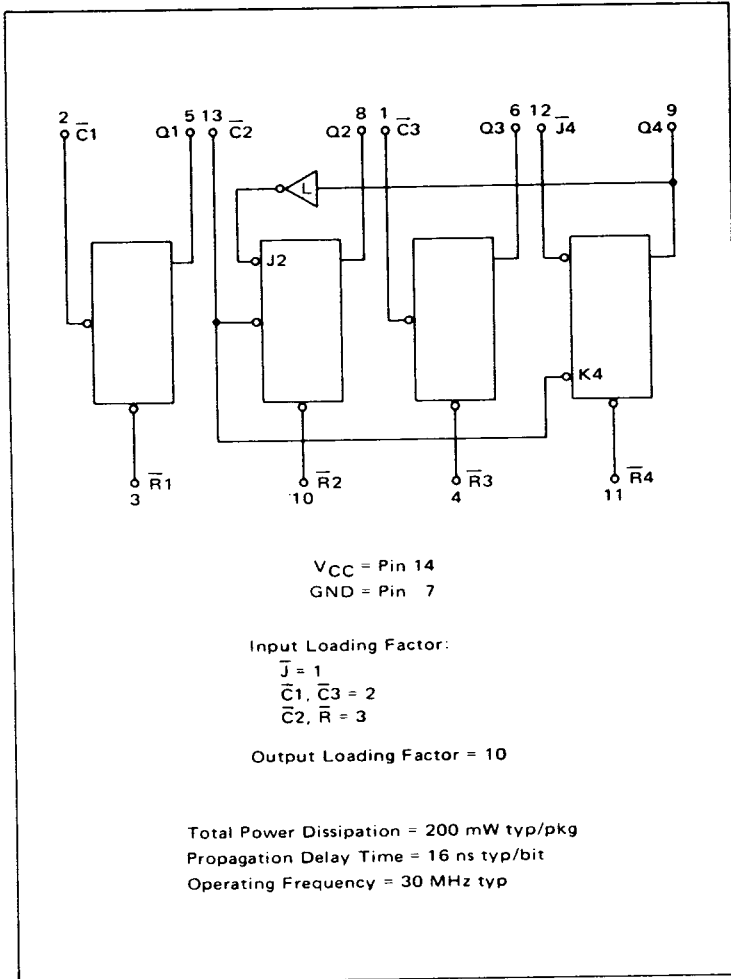

This device is a 4-bit counter with internally connected feedback. Inputs and outputs can be connected to count to any number between two and twelve except seven and eleven. Reset inputs are provided on each flip-flop to allow direct setting of the Q outputs to zero any time during the counting cycle.

Each flip-flop in the counter is built from high and low-level gates as shown by the logic diagram. The flip-flops and the feedback inverter are connected as shown by the block diagram to provide minimum power dissipation and maximum drive capability.

**LOGIC DIAGRAM**

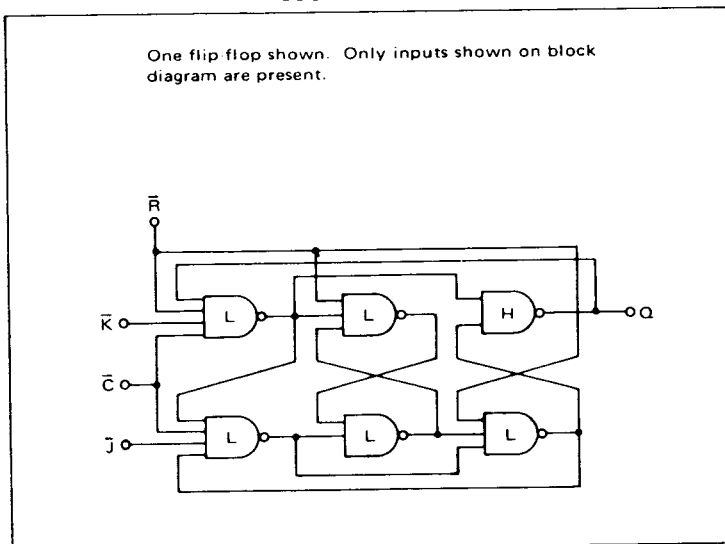



COUNTING SEQUENCES

**DIVIDE BY 2:** Use flip-flop 1 or 3.

**DIVIDE BY 3:** Use flip-flops 2 and 4, connected as shown. The input signal is applied to  $\bar{C}2$ ; the output is taken from Q4.

**DIVIDE BY 4:** Use flip-flops 1 and 3; connect Q1 to  $\bar{C}3$ . Apply the input signal to  $\bar{C}1$ .

**DIVIDE BY 6:** In addition to the connection for divide by 3, connect Q1 to  $\bar{C}2$ . Apply the input signal to  $\bar{C}1$ .

**DIVIDE BY 12:** In addition to the connections for divide by 6, connect Q3 to  $\bar{C}1$ . Apply the input signal to  $\bar{C}3$ .

$\bar{C}2$	Q2	Q4
0	0	0
1	1	0
2	0	1

$\bar{C}1$	Q1	Q3
0	0	0
1	1	0
2	0	1
3	1	1

$\bar{C}1$	Q1	Q2	Q4
0	0	0	0
1	1	0	0
2	0	1	0
3	1	1	0
4	0	0	1
5	1	0	1

$\bar{C}3$	Q3	Q1	Q2	Q4
0	0	0	0	0
1	1	0	0	0
2	0	1	0	0
3	1	1	0	0
4	0	0	1	0
5	1	0	1	0
6	0	1	1	0
7	1	1	1	0
8	0	0	0	1
9	1	0	0	1
10	0	1	0	1
11	1	1	0	1

**DIVIDE BY 5:** Connect flip flops 2, 3, and 4 as shown. The input signal is applied to  $\bar{C}2$ ; the output is taken from Q4.

**DIVIDE BY 8:** Connect flip-flops 2 and 3 as shown for divide by 5, but do not connect Q3 to  $\bar{J}4$ . Connect Q1 to  $\bar{C}2$ . The input signal is applied to  $\bar{C}1$ ; the output is taken from Q3.

$\bar{C}2$	Q2	Q3	Q4
0	0	0	0
1	1	0	0
2	0	1	0
3	1	1	0
4	0	0	1

$\bar{C}1$	Q1	Q2	Q3
0	0	0	0
1	1	0	0
2	0	1	0
3	1	1	0
4	0	0	1
5	1	0	1
6	0	1	1
7	1	1	1

$\bar{C}1$	Q1	Q2	Q3	Q4
0	0	0	0	0
1	1	0	0	0
2	0	1	0	0
3	1	1	0	0
4	0	0	1	0
5	1	0	1	0
6	0	1	1	0
7	1	1	1	0
8	0	0	0	1
9	1	0	0	1

**DIVIDE BY 10:** In addition to the connections for divide by 5, connect Q1 to  $\bar{C}2$ . Apply the input signal to  $\bar{C}1$ .

**DIVIDE BY 9:** The input signal is applied to  $\bar{C}2$ ; the output is taken from Q4.

$\bar{C}2$	Q2	Q3	Q1	Q4
0	0	0	0	0
1	1	0	0	0
2	0	1	0	0
3	1	1	0	0
4	0	0	1	0
5	1	0	1	0
6	0	1	1	0
7	1	1	1	0
8	0	0	0	1

DUAL  
VOLTAGE-CONTROLLED  
MULTIVIBRATOR

**MC4324**  
**MC4024**

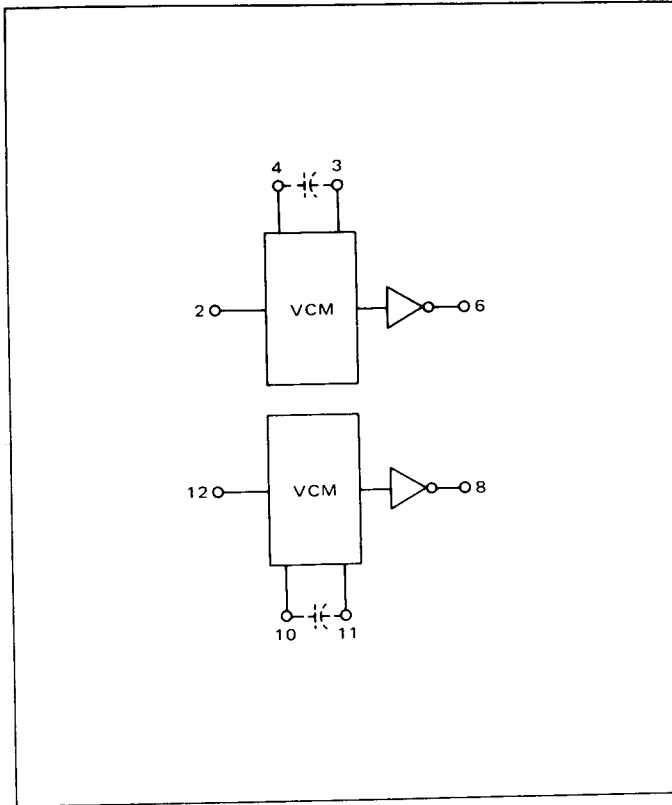

The MC4324/4024 voltage-controlled multivibrator provides appropriate level shifting to produce an output compatible with M TTL logic levels. Frequency control is accomplished through the use of voltage-variable current sources which control the slew rate of a single capacitor. Variation of the output frequency over a 3.5 to 1 range is possible with an input dc control voltage of +1.0 to +5.0 volts.

Voltage-controlled multivibrators are used in phase-locked loops for digital frequency control. They may also be used for some types of A to D converters.

VCC: VCM = 1, 13  
Output Buffer = 14

GND: VCM = 5, 9  
Output Buffer = 7

External Capacitor for  
Frequency Range Determination

Output Loading Factor = 7

Power Dissipation = 150 mW typ/pkg

Maximum Operating Frequency = 30 MHz typ

CIRCUIT SCHEMATIC

1/2 OF CIRCUIT SHOWN

(Numbers in brackets are pin numbers for other half.)

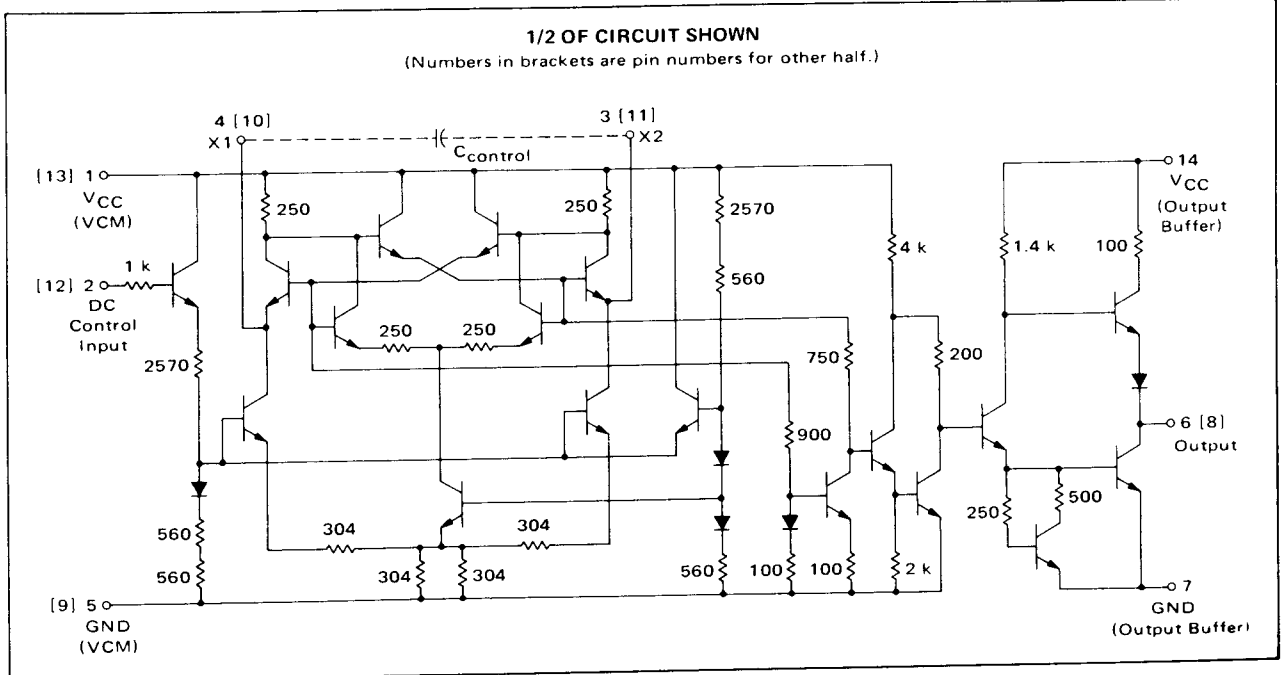

## FULL ADDERS

# MC4326 • MC4327 MC4026 • MC4027

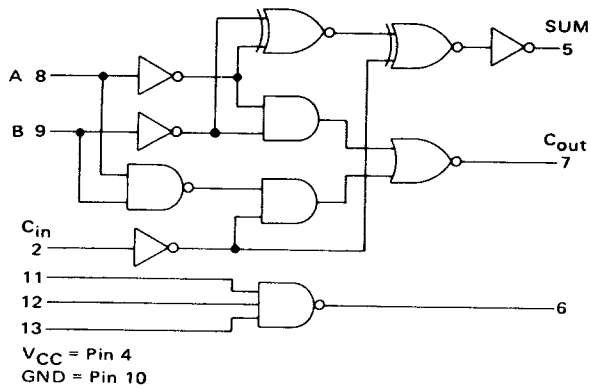

Input Loading Factor:

A, B = 2  
C<sub>in</sub>, Pins 11, 12, 13 = 1

Output Loading Factor:

MC4326 = 15 MTTL I Loads  
MC4327 = 7 MTTL I Loads  
MC4026 = 12 MTTL I Loads  
MC4027 = 6 MTTL I Loads

These full adders are designed for serial and ripple-carry parallel adder systems. True Sum and Carry are produced at the output from the input information. A separate 3-input NAND gate is provided on the monolithic chip to provide the inverted Sum or Carry output.

TRUTH TABLE

Input Pins			Output Pins	
8 A	9 B	2 C <sub>in</sub>	5 SUM	7 C <sub>out</sub>
0	0	0	0	0
0	0	1	1	0
0	1	0	1	0
0	1	1	0	1
1	0	0	1	0
1	0	1	0	1
1	1	0	0	1
1	1	1	1	1

Total Power Dissipation = 90 mW typ/pkg

Add Delay = 25 ns typ

Carry Delay = 13 ns typ

## CIRCUIT SCHEMATIC

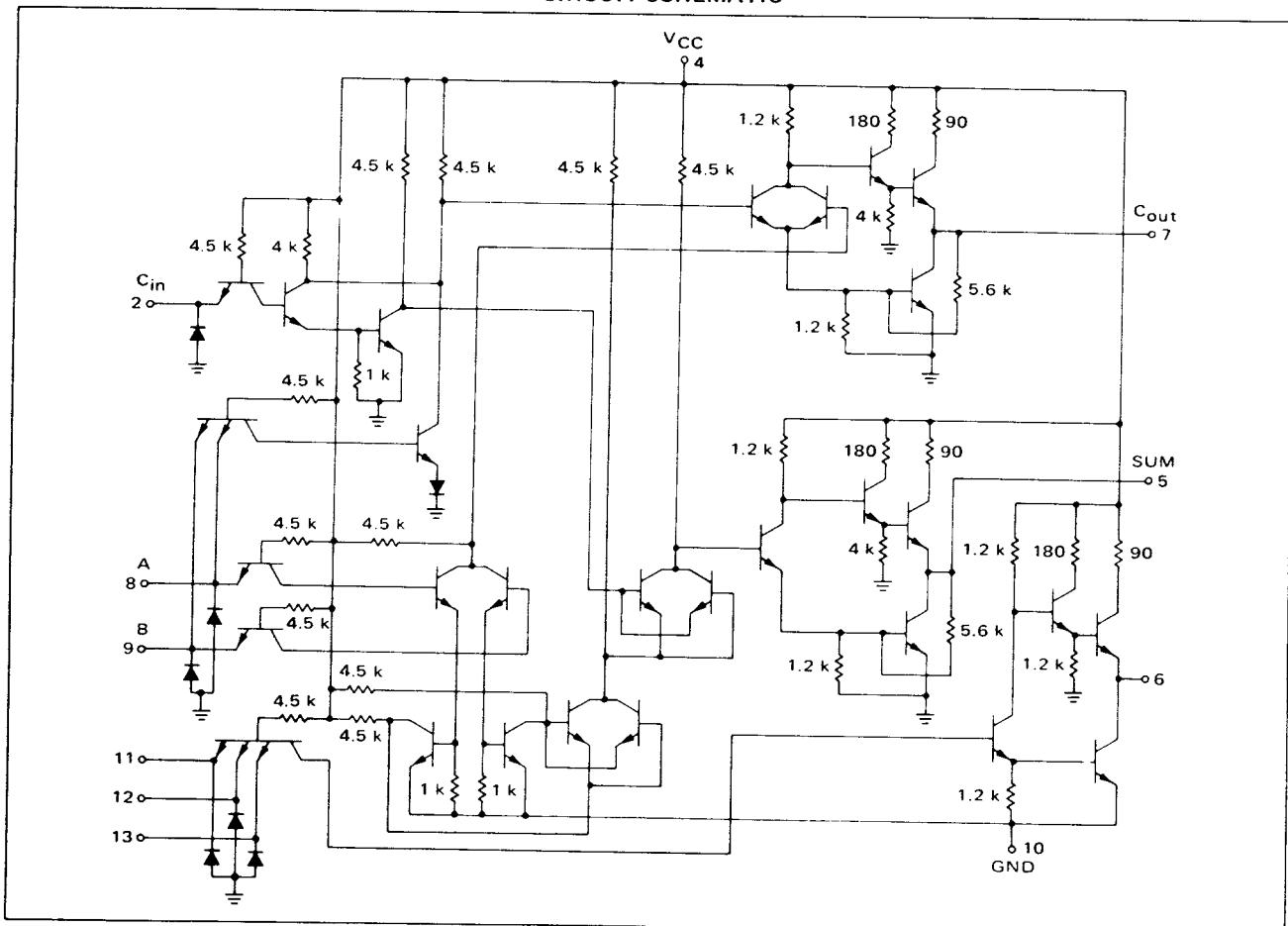

ADDERS

MC4328 thru MC4331  
MC4028 thru MC4031

CONDENSED TRUTH TABLE FOR THE Nth STAGE

		Pin Numbers								
8	9	11	12,13	13, 14, 1	5	6	7	7		
$A_n$	$B_n$	$C_{in1(n-1)}$	Note 1	Note 2	Sum	$\oplus_{out}$	MC4330/4030 MC4331/4031 $C_{out}$	MC4328/4028 MC4329/4029 $C_{out}$	Comment Note 3	
0	0	0	0	0	0	0	0	0	-	
0	0	0	1	1	1	1	0	0	-	
0	0	0	1	0	1	0	0	0	$\phi$	
0	0	0	1	1	1	0	0	0	$\phi$	
0	0	1	0	0	1	0	0	0	$\phi$	
0	0	1	1	0	1	0	0	0	$\phi$	
0	0	1	1	1	1	0	0	0	$\phi$	
0	1	0	0	0	0	1	0	1	-	
0	1	0	1	0	0	1	0	1	-	
0	1	0	1	1	0	1	0	1	$\phi$	
0	1	1	0	0	0	1	0	1	$\phi$	
0	1	1	1	0	0	1	0	1	$\phi$	
0	1	1	1	1	0	1	0	1	$\phi$	
1	0	0	0	0	1	1	0	0	-	
1	0	0	1	1	0	1	0	0	-	
1	0	0	1	0	0	1	0	1	$\phi$	
1	0	0	1	1	0	1	0	1	$\phi$	
1	0	1	0	0	0	1	0	1	-	
1	0	1	1	0	0	1	0	1	-	
1	0	1	1	1	0	1	0	1	$\phi$	
1	1	0	0	0	0	0	1	1	-	
1	1	0	1	0	1	0	1	1	-	
1	1	0	1	1	0	1	1	1	$\phi$	
1	1	1	0	0	1	0	1	1	$\phi$	
1	1	1	1	0	1	0	1	1	$\phi$	
1	1	1	1	1	1	0	1	1	$\phi$	
1	1	1	1	1	1	1	1	1	$\phi$	

Note 1. This column represents the AND function whose inputs are pins 13 and 12, and is defined by the expression  $(A_n \uparrow \oplus B_n \uparrow) \uparrow (C_{in1} \uparrow n \uparrow 2 \uparrow)$

Note 2. This column represents the AND function whose inputs are pins 13, 14, and 1, and is defined by the expression  $(A_n \uparrow \oplus B_n \uparrow) \uparrow (A_n \uparrow 2 \uparrow \oplus B_n \uparrow 2 \uparrow \uparrow C_{in1} \uparrow 3 \uparrow)$

Note 3.  $\phi$  "Don't Care". The "Don't Care" occurs for the MC4330/31/4030/31 only, because the  $C_{in}$  and the  $\oplus_{in}$  from any one previous stage entering a given subsequent stage cannot be simultaneously at logic "1"

This family of fast adders is designed for use in parallel look-ahead carry adder applications where high-speed addition is required. The dependent-carry fast adders have a Carry output that is dependent upon the two input bits for that stage plus the Carry input from all previous stages. The Carry output from the MC4330/31 is independent of the carry from the previous stages.

Input Loading Factor:

$\oplus_{in1}$ , A, B = 2  
 $\oplus_{in2}$ ,  $C_{in1}$ ,  $C_{in2}$ ,  $C_{in3}$  = 1

Output Loading Factor:

- MC4328, MC4330 = 15 MTTL I Loads
- MC4329, MC4331 = 7 MTTL I Loads
- MC4028, MC4030 = 12 MTTL I Loads
- MC4029, MC4031 = 6 MTTL I Loads

Total Power Dissipation = 125 mW typ/pkg

Add Delay = 25 ns typ

Carry Delay = 13 ns typ

DEPENDENT-CARRY FAST ADDER  
MC4328/4028, MC4329/4029

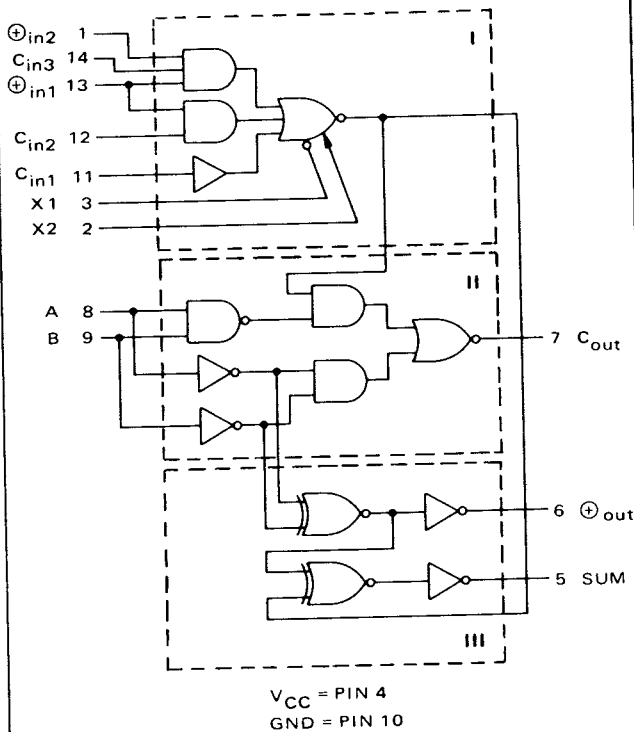

INDEPENDENT-CARRY FAST ADDER  
MC4330/4030, MC4331/4031

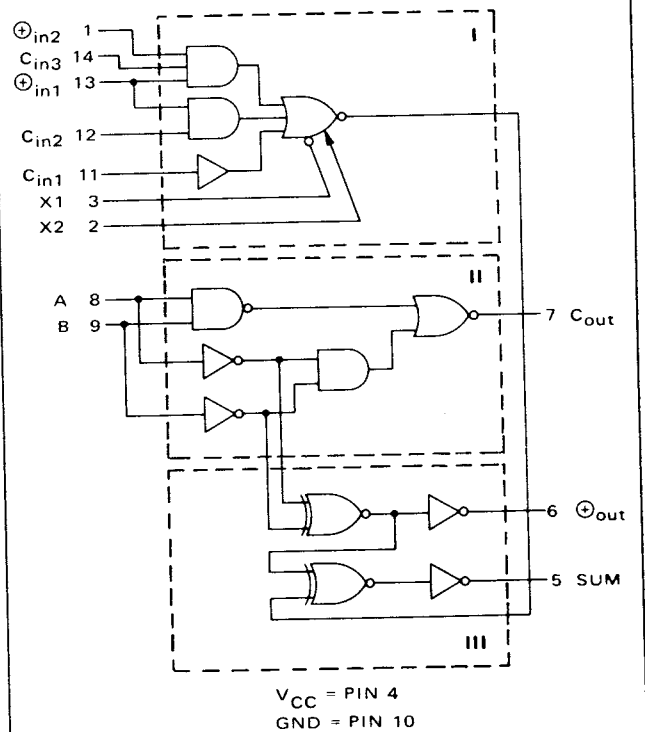

CARRY DECODER

**MC4332**  
**MC4032**

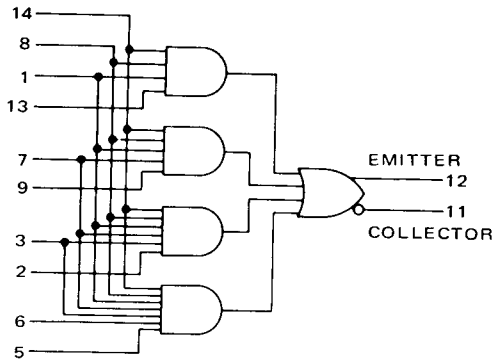

VCC = Pin 4  
GND = Pin 10

This 4-wide 4, 5, 6, 7 input AND-OR expander provides the necessary logic for carry decoding between look-ahead carry adder stages using the MC4328/29 and MC4330/31 fast adders.

Input Loading Factor:

- Pins 1, 8, 14 = 4
- Pin 7 = 3
- Pin 3 = 2
- Pins 2, 5, 6, 9, 13 = 1

Total Power Dissipation = 20 mW typ/pkg

$\Delta t_{pd}$  = 4.0 ns typ/decoder

1.0 ns typ/pF at expander nodes

TYPICAL APPLICATION

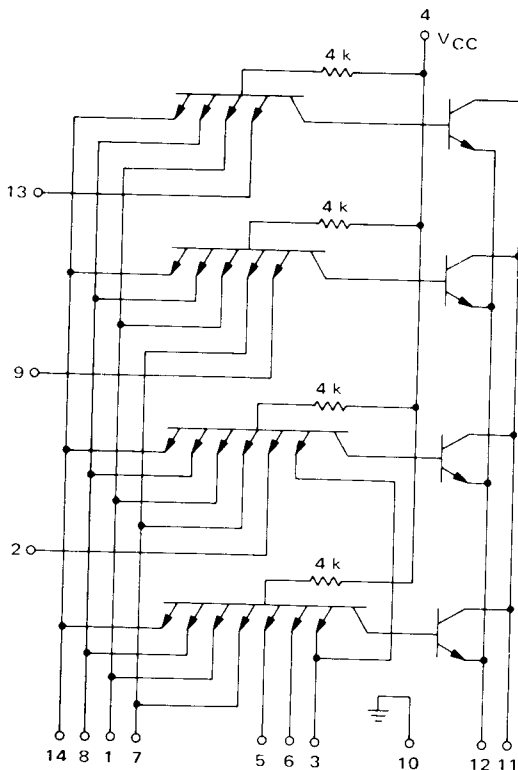

The MC4328/29 and MC4330/31 adders can be used with the MC4332 Carry Decoder to build 8-stage look-ahead carry subsystems. (See the MC4328-31 data sheet for a diagram.) Each stage examines the carry outputs from all previous stages while adding bits A and B for that stage. The carry outputs of the first and eighth stages are dependent upon the carry inputs from previous stages; thus the MC4328/29 adder is used for stages one and eight while the MC4330/31 adder is used for stages two through seven. The MC4332 Carry Decoder is used to expand the look-ahead carry input capability required for stages four through eight.

The add delay of an eight stage adder is equal to the sum of the add delay and the delay from the A and B inputs to the  $\oplus$  output of one stage. Thus the typical add delay for an 8-stage adder is 25 ns + 13 ns or 38 ns typical.

When expander inputs are not used they should not be connected to any external point. This minimizes possible problems resulting from noise pick-up.

**QUAD LATCH  
(Open Collector)**

**MC4335  
MC4035**

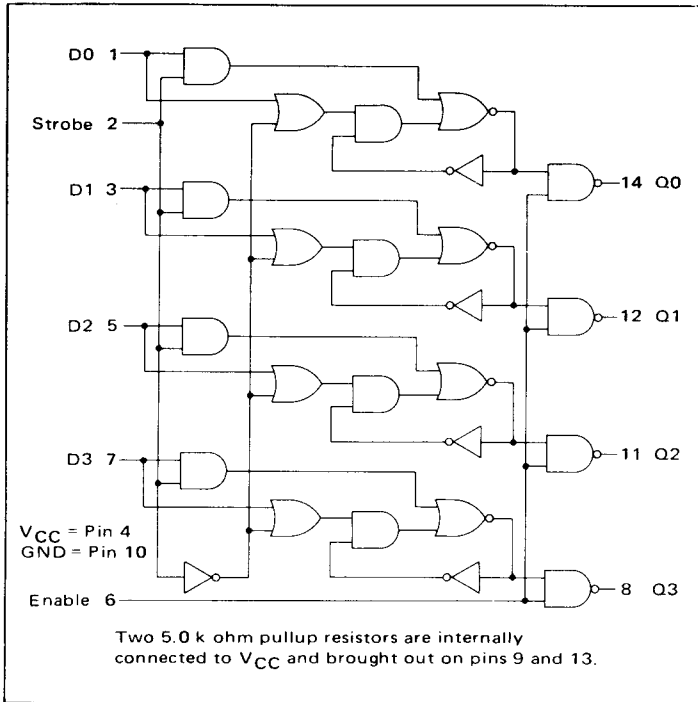

This monolithic device consists of four latch circuits with open collector outputs, common Strobe input, and output enable input. The output of each latch will follow the data input when the Strobe input is in a logical "1" state. When the Strobe is in a logical "0" state, the latch will store the logic state of the data input just prior to the change of the Strobe from a "1" level to a "0" level.

The open collector outputs make this device useful for bussing or wire ORing outputs together. Two 5.0 k ohm resistors are available in the package to provide the passive pullup function in wired-OR or bussed operation. The output enable is useful where it is desirable to gate information out of the latches according to a predetermined timing scheme.

**Input Loading Factor (MTTL I Loads):**

Data Input (Strobe High) – MC4335 = 4.2  
MC4035 = 4.0

Data Input (Strobe Low) – MC4335 = 1.1  
MC4035 = 0.9

Output Enable – MC4335 = 4.0  
MC4035 = 3.6

Strobe – MC4335 = 5.2  
MC4035 = 5.2

**Output Loading Factor (MTTL I Loads):**

MC4335 = 7 ( $I_{OL} = 9.3$  mAdc)  
MC4035 = 7 ( $I_{OL} = 11.6$  mAdc)

Total Power Dissipation = 140 mW typ/pkg  
Propagation Delay Time = 25 ns typ

**CIRCUIT SCHEMATIC**

**1/4 OF DEVICE SHOWN**

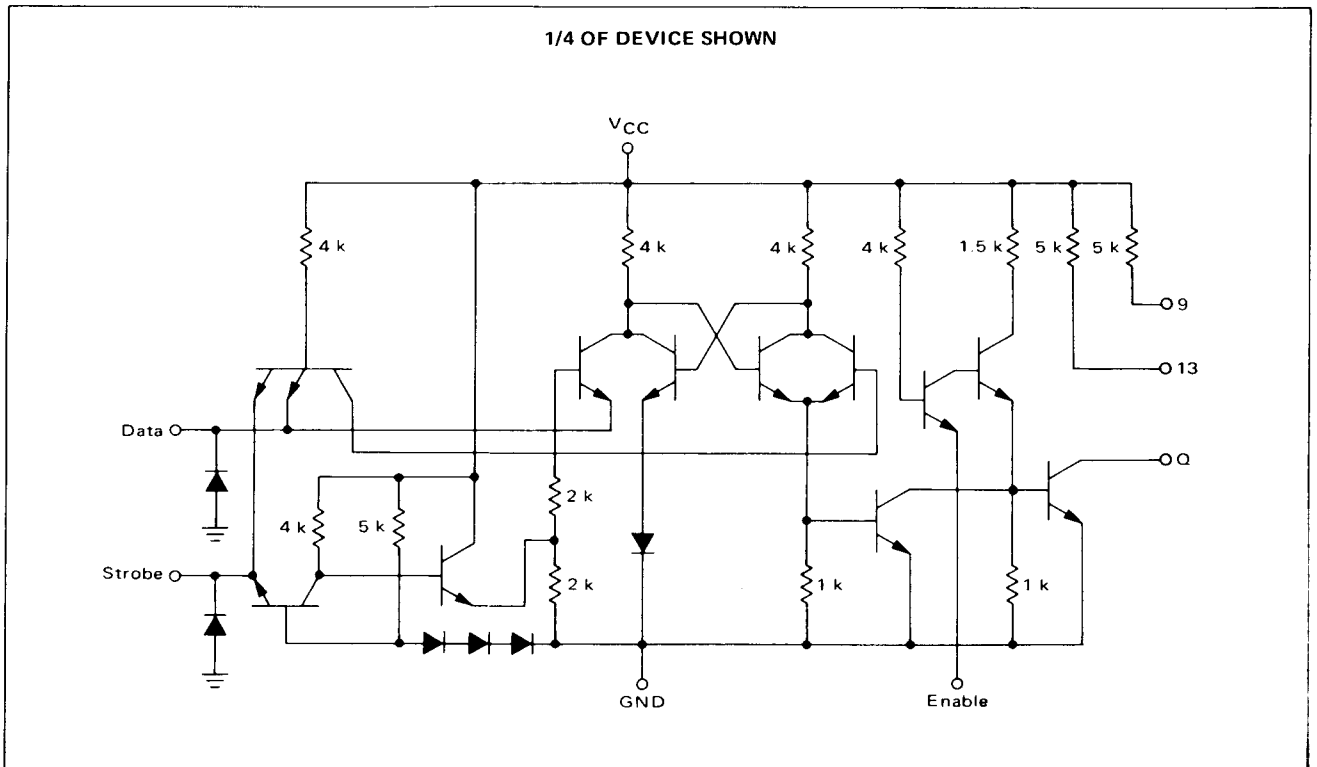

QUAD LATCH

**MC4337**  
**MC4037**

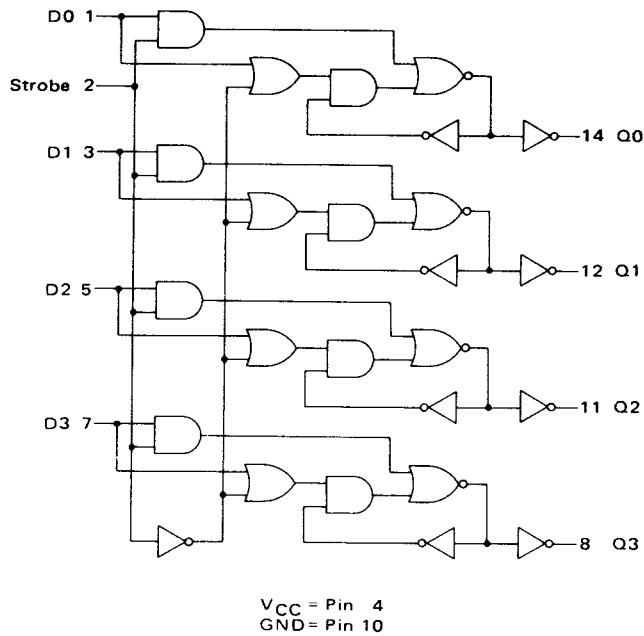

This monolithic device consists of four latch circuits with active pullup networks for high capacitive load drive capability. Separate data inputs and a common Strobe input are provided. Information present on the data inputs prior to the negative edge of the strobe input will be stored in the latch. When the strobe input is high, the Q output will follow the data input.

Input Loading Factor (MTTL I Loads):

Data Input (Strobe High) – MC4337 = 4.2  
MC4037 = 4.0  
Data Input (Strobe Low) – MC4337 = 1.1  
MC4037 = 0.9

Strobe – MC4337 = 5.2  
MC4037 = 5.2

Output Loading Factor (MTTL I Loads):

MC4337 = 10 (I<sub>OL</sub> = 13.3 mA<sub>dc</sub>)  
MC4037 = 10 (I<sub>OL</sub> = 16.6 mA<sub>dc</sub>)  
Total Power Dissipation = 150 mW typ/pkg  
Propagation Delay Time = 25 ns typ

CIRCUIT SCHEMATIC

1/4 OF DEVICE SHOWN

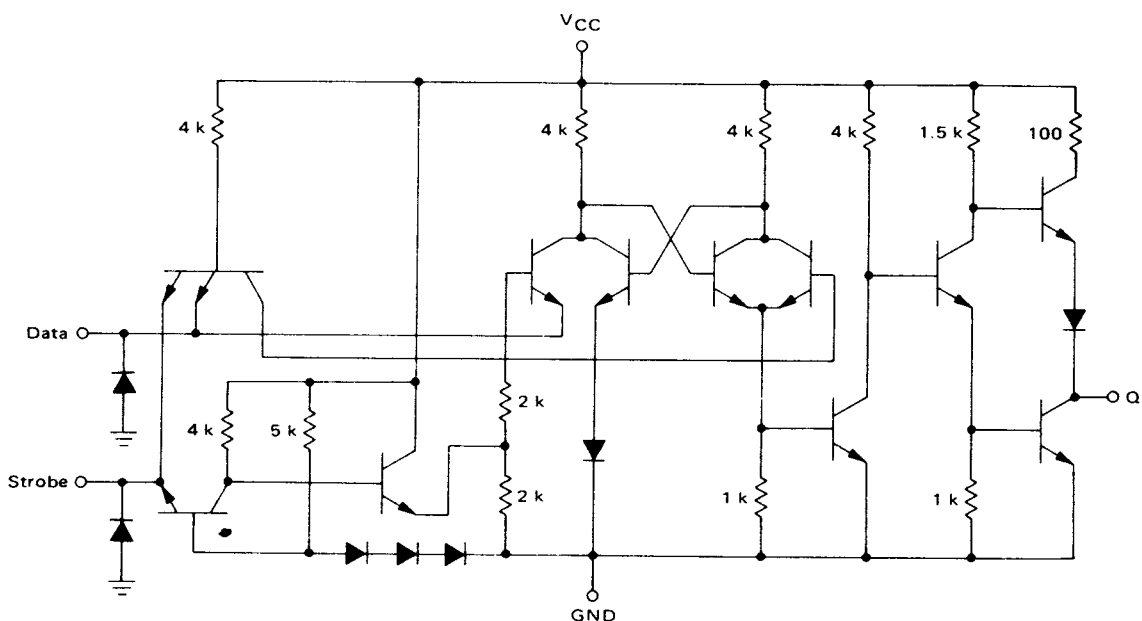

**INVERTING/NON-INVERTING  
ONE-OF-EIGHT DECODER**

**MC4338  
MC4038**

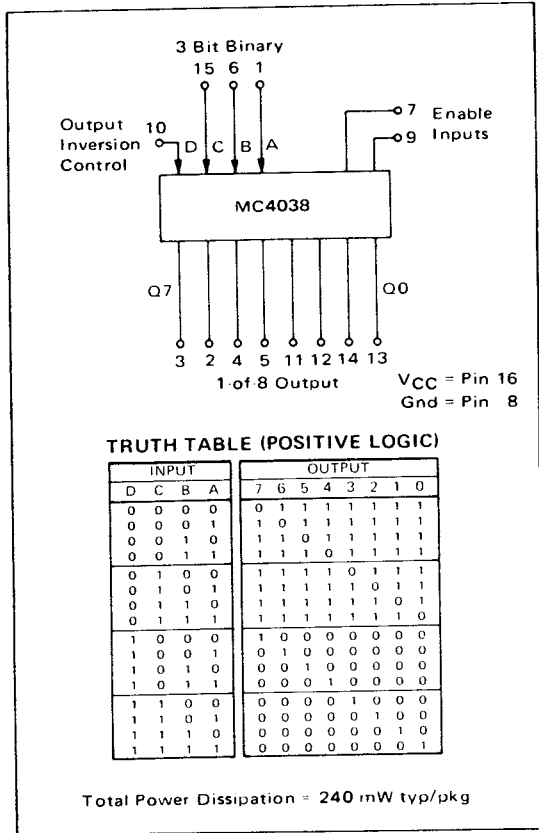

A 3-bit binary address selects the desired word for the 8-bit output. The inversion control, D, selects half of the memory chip with the bit pattern that defines a 1-of-8 decoder function. When D is a logic "0", the selected output is designated as a logic "0". A logic "1" on D produces a logic "1" on the selected output.

**Features:**

- Address times < 45 ns
- Outputs sink 20 mA
- Output capacitance < 7.0 pF @ 1.5 V
- Wired OR capability to 64 memories

**ENABLE INPUT TRUTH TABLE (POSITIVE LOGIC)**

E	E	Q7	Q6	Q5	Q4	Q3	Q2	Q1	Q0
0	0	1	1	1	1	1	1	1	1
0	1	1	1	1	1	1	1	1	1
1	0	1	1	1	1	1	1	1	1
1	1	FUNCTION ENABLED							

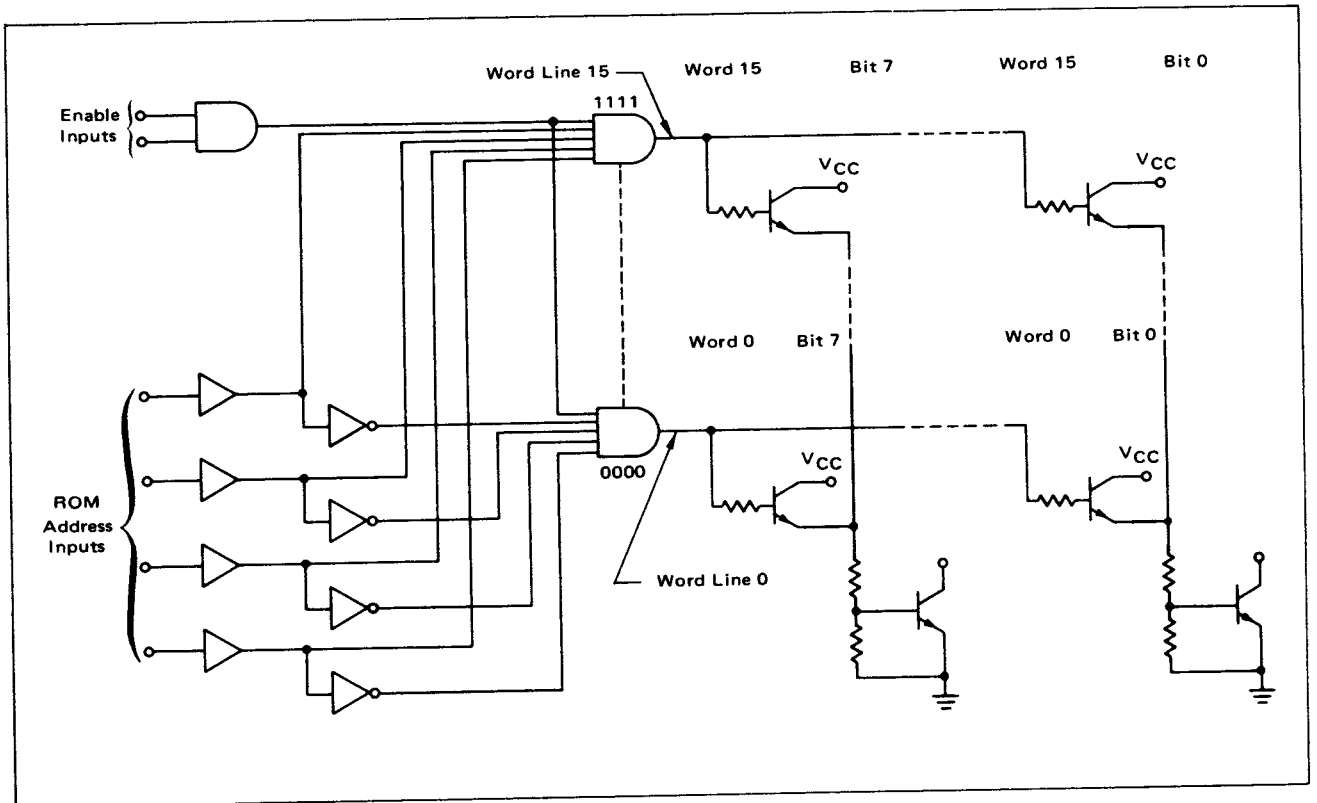



SEVEN-SEGMENT  
CHARACTER GENERATOR

MC4339  
MC4039

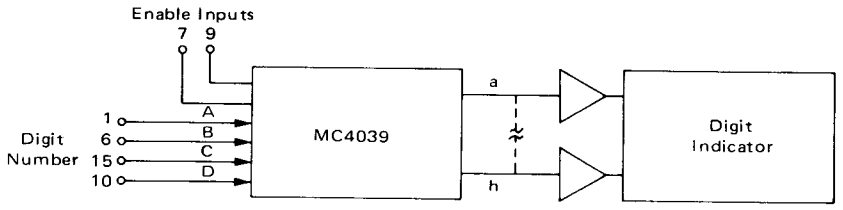

Output	a	b	c	d	e	f	g	h
Pin No.	12	11	5	4	13	14	2	3

VCC = Pin 16  
Gnd = Pin 8

Total Power Dissipation = 240 mW typ/pkg

The MC4339 can directly operate low-voltage lamp indicators. A four digit binary input is translated into combinations of the eight outputs. These combinations correspond to different illuminated segments of the seven-bar digit indicator. The input and output codes with their related numerical digits are shown in the diagram. The enable inputs can be used for automatic blanking.

TRUTH TABLE (POSITIVE LOGIC)

Digit Indicator	DIGIT	SEGMENTS ILLUMINATED	INPUT				OUTPUT								
			D	C	B	A	a	b	c	d	e	f	g	h	
	0	a,b,c,d,e,f	0	0	0	0	0	0	0	0	0	0	0	1	1
	1	b,c	0	0	0	1	1	0	0	1	1	1	1	1	1
	2	a,b,d,e,g	0	0	1	0	0	0	1	0	0	1	0	1	0
	3	a,b,c,d,g	0	0	1	1	0	0	0	0	0	1	1	0	1
	4	b,c,f,g	0	1	0	0	1	0	0	1	1	0	0	0	1
	5	a,c,d,f,g	0	1	0	1	0	1	0	0	1	0	0	0	1
	6	c,d,e,f,g	0	1	1	0	1	1	0	0	0	0	0	0	1
	7	a,b,c	0	1	1	1	0	0	0	0	1	1	1	1	1
	8	a,b,c,d,e,f,g	1	0	0	0	0	0	0	0	0	0	0	0	1
	9	a,b,c,f,g	1	0	0	1	0	0	0	0	1	1	0	0	1
	NONE		1	0	1	0	1	1	1	1	1	1	1	1	1
	•	h (Ext.)	1	0	1	1	1	1	1	1	1	1	1	1	0
		g	1	1	0	0	1	1	1	1	1	1	0	1	
	NONE		1	1	0	1	1	1	1	1	1	1	1	1	
	NONE		1	1	1	0	1	1	1	1	1	1	1	1	
	NONE		1	1	1	1	1	1	1	1	1	1	1	1	

Features:

- Address times < 45 ns
- Outputs sink 20 mA
- Output capacitance < 7.0 pF @ 1.5 V
- Wired OR capability to 64 memories

ENABLE INPUT TRUTH TABLE (POSITIVE LOGIC)

E	E	a	b	c	d	e	f	g	h
0	0	1	1	1	1	1	1	1	1
0	1	1	1	1	1	1	1	1	1
1	0	1	1	1	1	1	1	1	1
1	1	1	1	1	1	1	1	1	1
1	1	FUNCTION ENABLED							

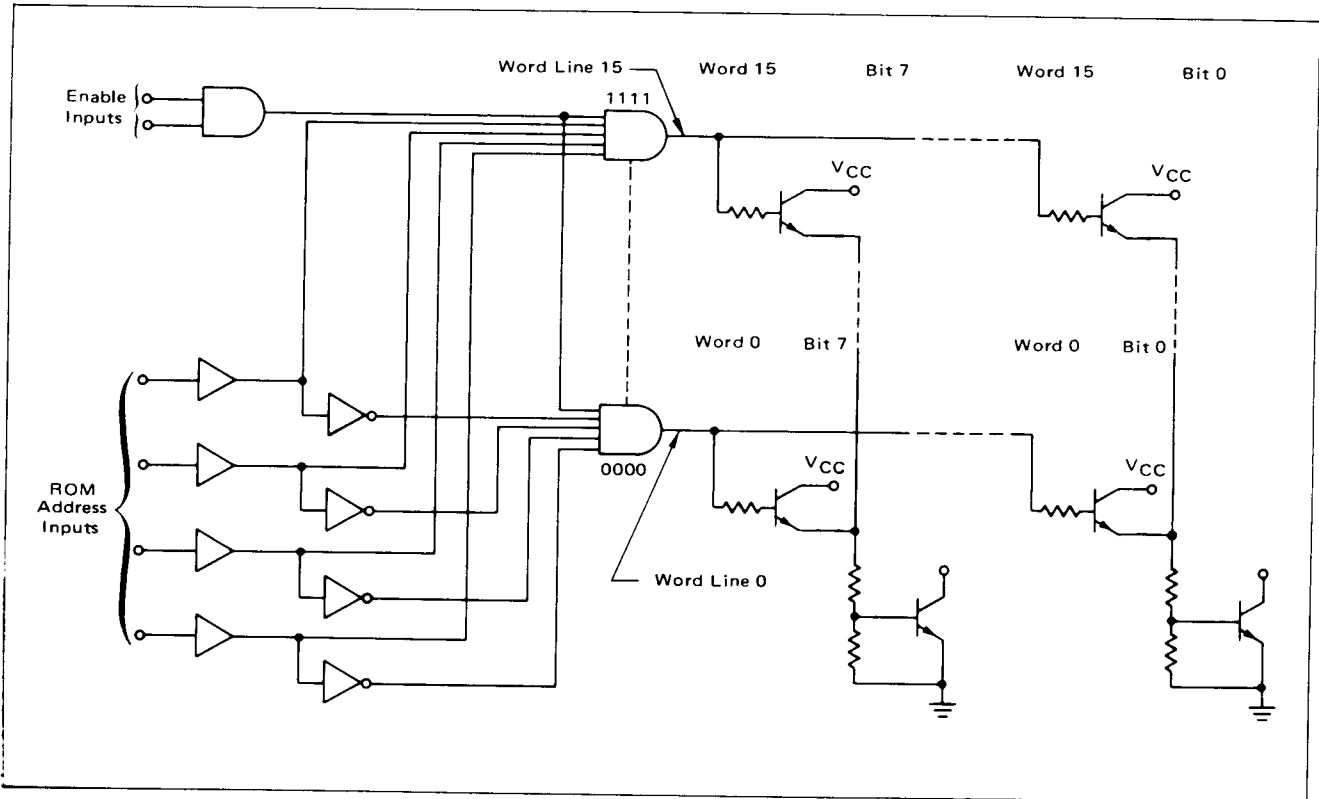

**BINARY TO  
TWO-OF-EIGHT DECODER**

**MC4340  
MC4040**

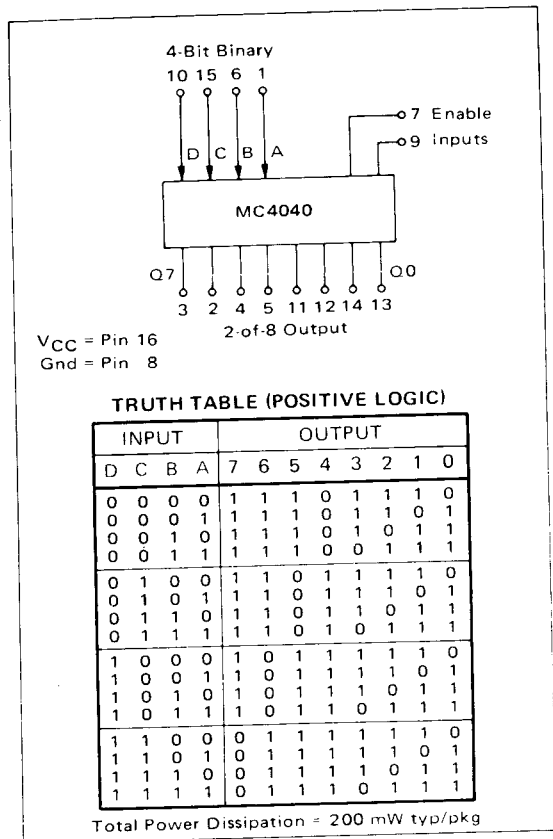

This device, with two enable inputs, transforms any 4-bit binary number to a 2-of-8-bit coded number. The device can also be thought of as a dual binary to 1-of-4 decoder.

**Features:**

- Address times < 45 ns
- Outputs sink 20 mA
- Output capacitance < 7.0 pF @ 1.5 V
- Wired OR capability to 64 memories

**ENABLE INPUT TRUTH TABLE (POSITIVE LOGIC)**

E	E	Q7	Q6	Q5	Q4	Q3	Q2	Q1	Q0
0	0	1	1	1	1	1	1	1	1
0	1	1	1	1	1	1	1	1	1
1	0	1	1	1	1	1	1	1	1
1	1	FUNCTION ENABLED							

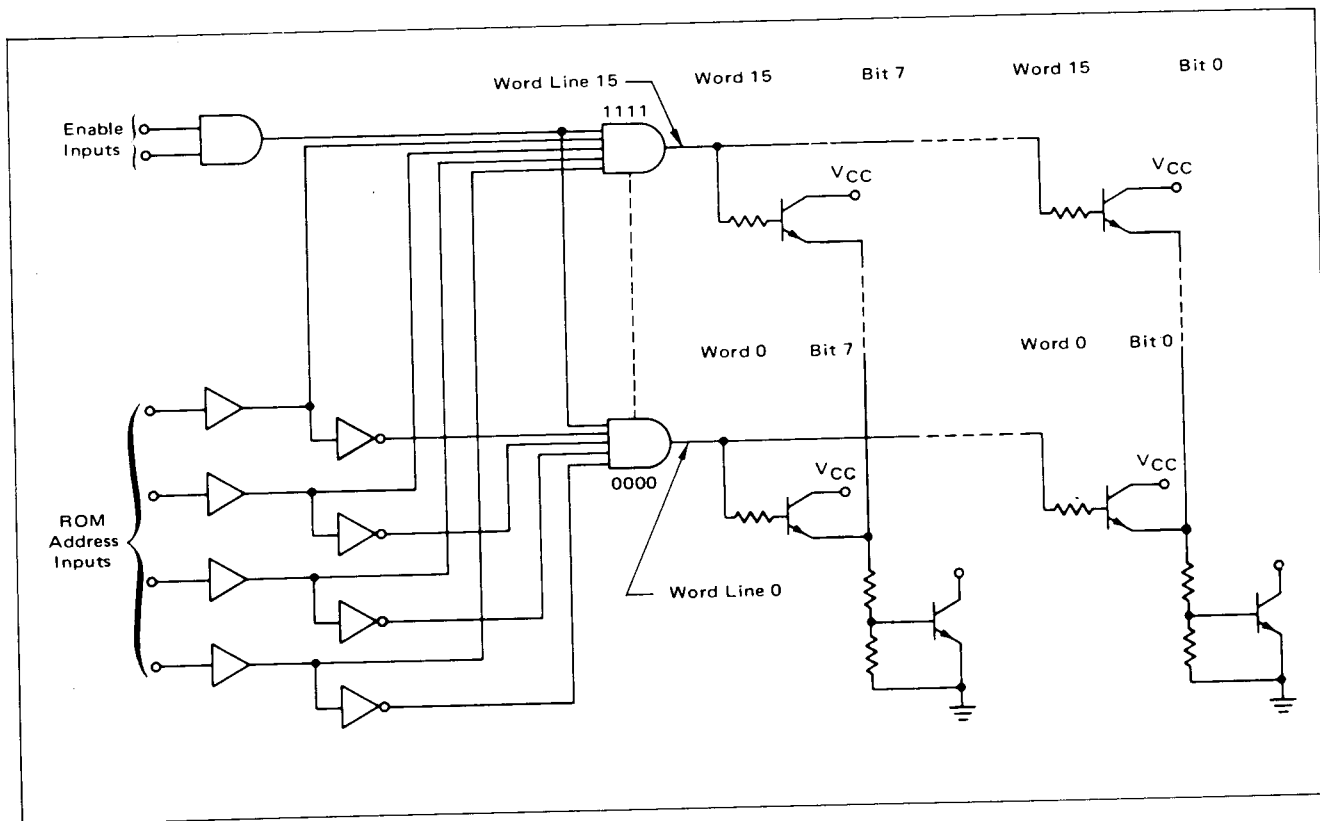

# SINGLE-ERROR HAMMING CODE DETECTOR AND GENERATOR MC4341 MC4041

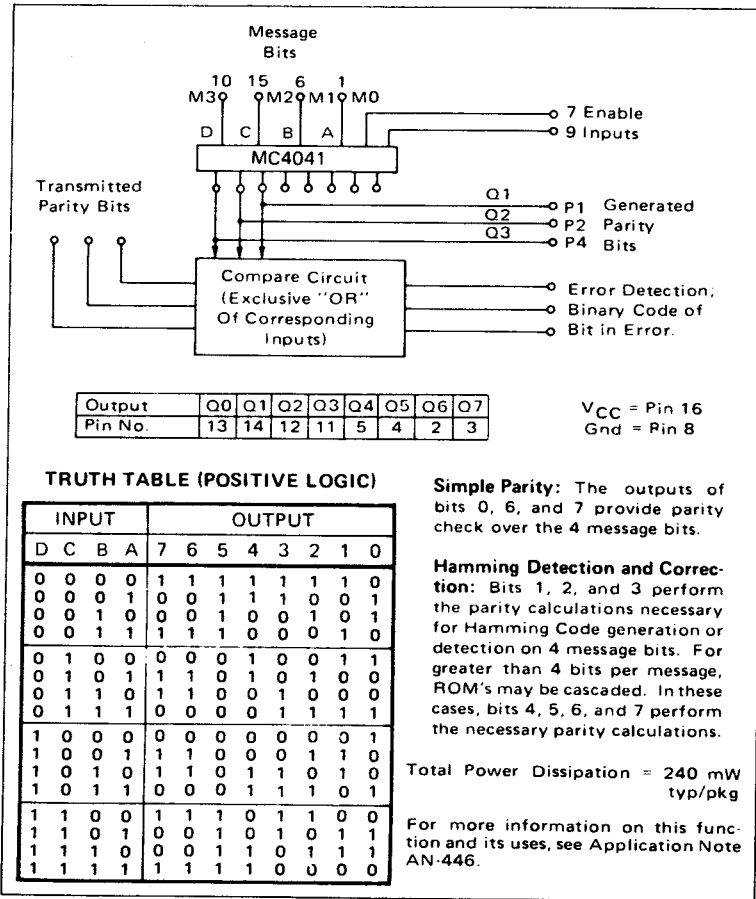

The MC4041 is a programmed 128-Bit Read Only Memory suitable for a variety of error detection and correction applications.

Simple parity trees for error detection can be constructed using the MC4041P as the basic building block. Also, more complex error control schemes, such as Hamming single error detection and correction, can be implemented with this device.

**Features:**

- Address times < 45 ns
- Outputs sink 20 mA
- Output capacitance < 7.0 pF @ 1.5 V
- Wired OR capability to 64 memories

**ENABLE INPUT TRUTH TABLE (POSITIVE LOGIC)**

E	E	Q7	Q6	Q5	Q4	Q3	Q2	Q1	Q0
0	0	1	1	1	1	1	1	1	1
0	1	1	1	1	1	1	1	1	1
1	0	1	1	1	1	1	1	1	1
1	1	FUNCTION ENABLED							

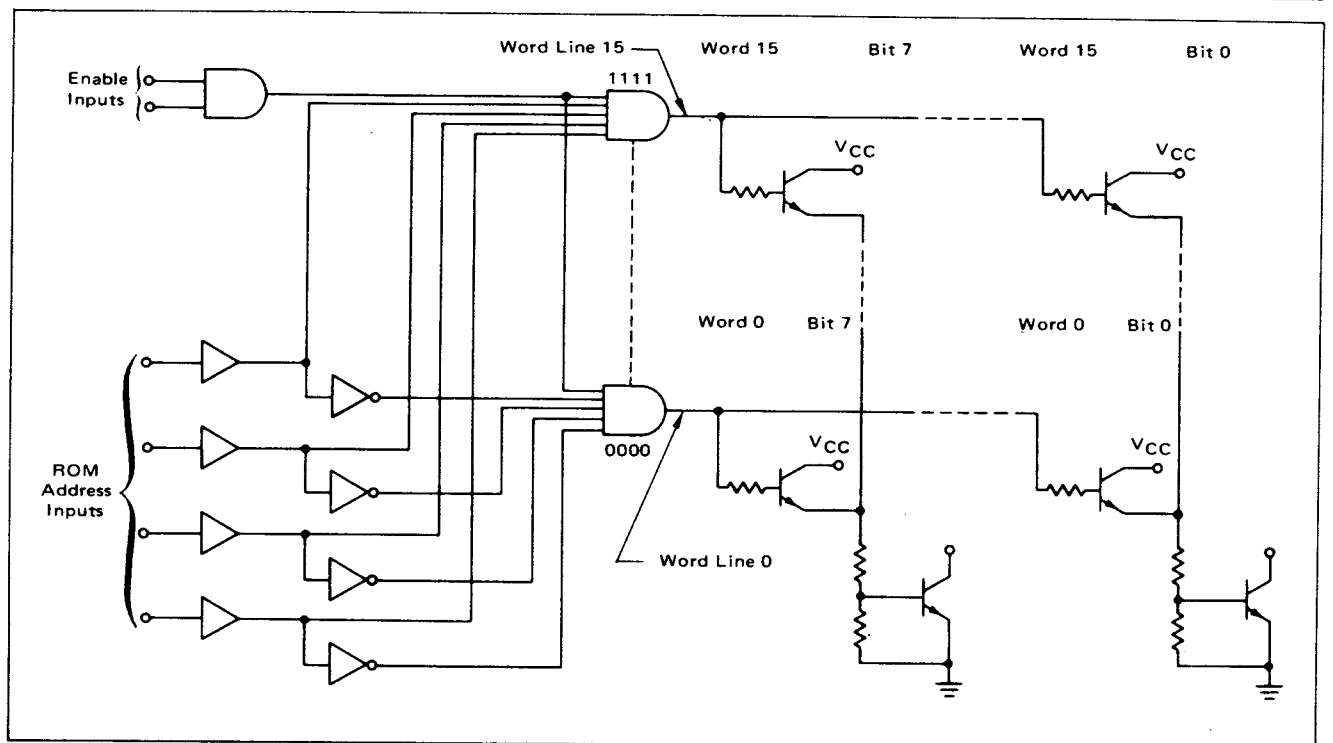
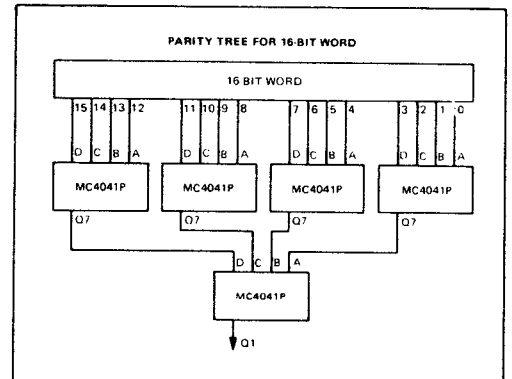

PHASE-FREQUENCY  
DETECTOR

MC4344  
MC4044

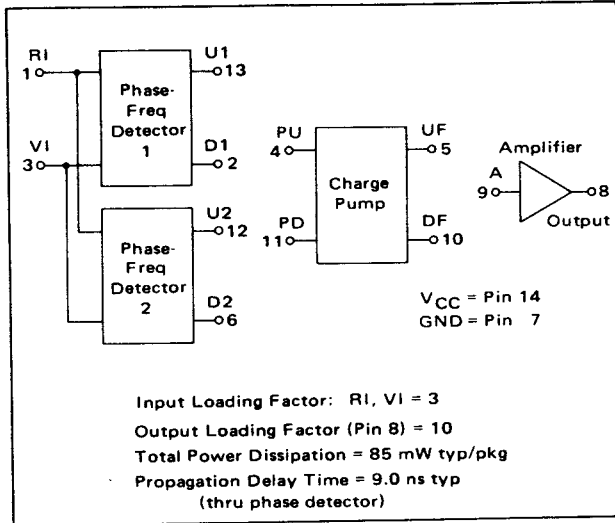

This device contains two digital phase detectors and a charge pump circuit which converts M TTL inputs to a dc voltage level for use in frequency discrimination and phase-locked-loop applications.

The two phase detectors have common inputs. Phase-frequency detector 1 is locked in (indicated by both outputs high) when the negative transitions of the variable input (VI) and reference input (RI) are equal in frequency and phase. If the variable input is lower in frequency or lags in phase, the U1 (up) output goes low; conversely the D1 (down) output goes low when the variable input is higher in frequency or leads the reference input in phase. It is important to note that the duty cycles of the variable input and the reference input are not important since negative transitions control system operation.

Phase detector 2, on the other hand, is locked in when the variable input phase lags the reference phase by  $90^\circ$  (indicated by the U2 and D2 outputs alternately going low with equal pulse widths). If the variable input phase lags by more than  $90^\circ$ , U2 will remain low longer than D2, and, conversely, if the variable input phase lags the reference phase by less than  $90^\circ$ , D2 remains low longer. In this phase detector the variable input and the reference must have 50% duty cycles.

The charge pump accepts the phase detector outputs (U1 or U2 applied to PU, and D1 or D2 applied to PD) and converts them to fixed amplitude positive and negative pulses at the UF and DF outputs respectively. These pulses are applied to a lag-lead active filter, which incorporates external components, as well as the amplifier provided in the MC4344/4044 circuit. The filter provides a dc voltage proportional to the phase error.

PHASE DETECTOR

The phase detector portion of this device is constructed using low and high-level gates interconnected as shown by the logic diagram.

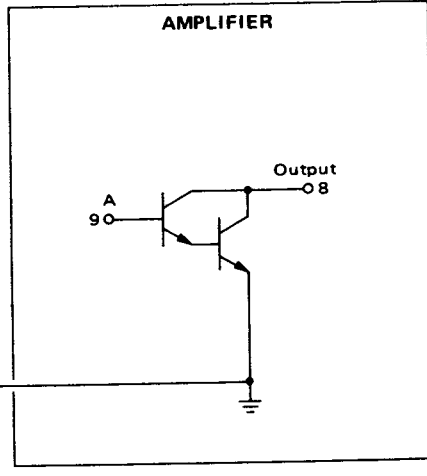
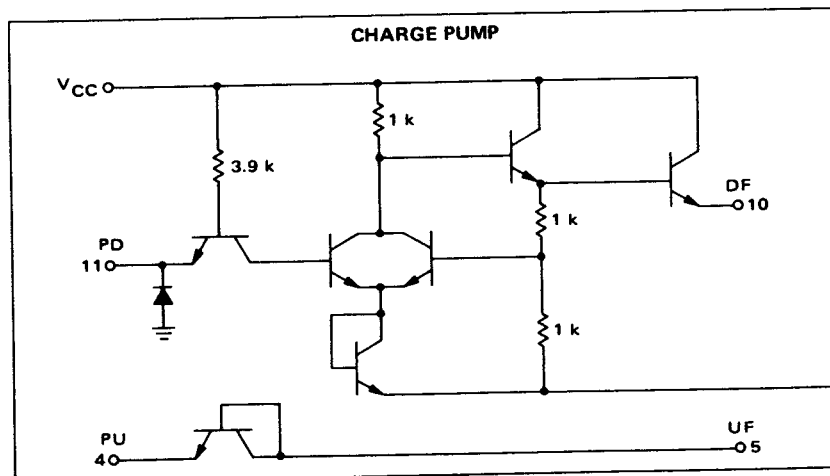
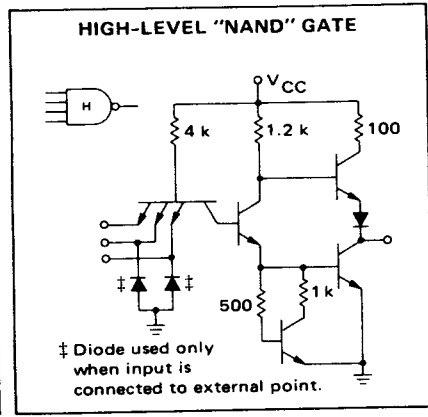
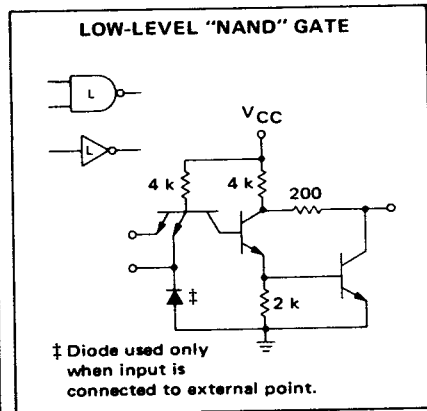
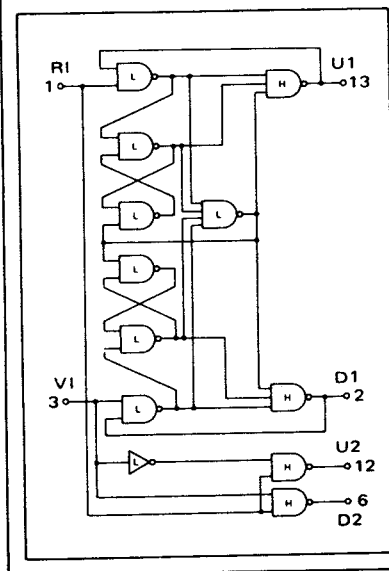

QUAD PREDRIVER

DUAL LINE SELECTOR

**MC4342**  
**MC4042**

**MC4343**  
**MC4043**

The MC4042 and MC4043 are designed for magnetic memory driver/selector applications.

The MC4042 monolithic quad predriver consists of four high-speed switching transistors, each driven by an MTTL compatible NOR gate. Each NOR gate has an individual address input and a common timing input. The inputs of the MC4042 can be driven directly with standard MTTL decoders such as the MC4006 binary to one-of-eight decoder or the MC4007 dual binary to one-of-four decoder. The open-collector output transistor of the MC4042 will sink 50 mA.

The MC4043 monolithic dual line selector consists of two high-speed 400 mA switches driven by MTTL compatible NOR gates. Each NOR gate has an individual address input and a common timing input. The address and timing inputs of the MC4043 can also be driven directly with standard MTTL decoders such as the MC4006 and MC4007.

The MC4042 and MC4043 input circuits are the same, but the output circuitry is different as shown in the device schematics. The output transistors of both devices have a minimum  $BV_{CEX}$  of 15 volts, and are gold doped to increase switching speeds.

Many memory predriver applications employ transformer coupling between the predriver and driver stages. In such designs, large

voltage overshoots occur due to the transformer inductance and high-speed switching currents. The collector of the MC4042 is internally clamped to prevent the collector from exceeding the maximum rated voltage during the switching transitions. The voltage applied to the diode clamp, pin 5, should be the same or greater than the collector voltages at pins 1, 7, 8, and 14, to prevent the diode clamp from being forward biased during nonswitching periods. The output transistor is driven with a conventional totem pole arrangement to provide active pullup and pulldown.

The collectors of the pullup transistors of the MC4043 are available at pins 1 and 7. An external load resistor to  $V_{CC}$  must be provided. This reduces power dissipation of the package and provides a means by which the speed of the device can be varied by changing the value of the pullup resistance.

The internal decoding circuitry of the MC4043 is such that both switches can be turned on at one time. However, due to power limitations, care must be taken to ensure that only one switch is turned on at any one time.

The MC4042 and MC4043 can provide a memory system with an inexpensive, reliable, fast drive system. They are also useful as relay or lamp drivers, high fan-out gates, and MOS drivers.

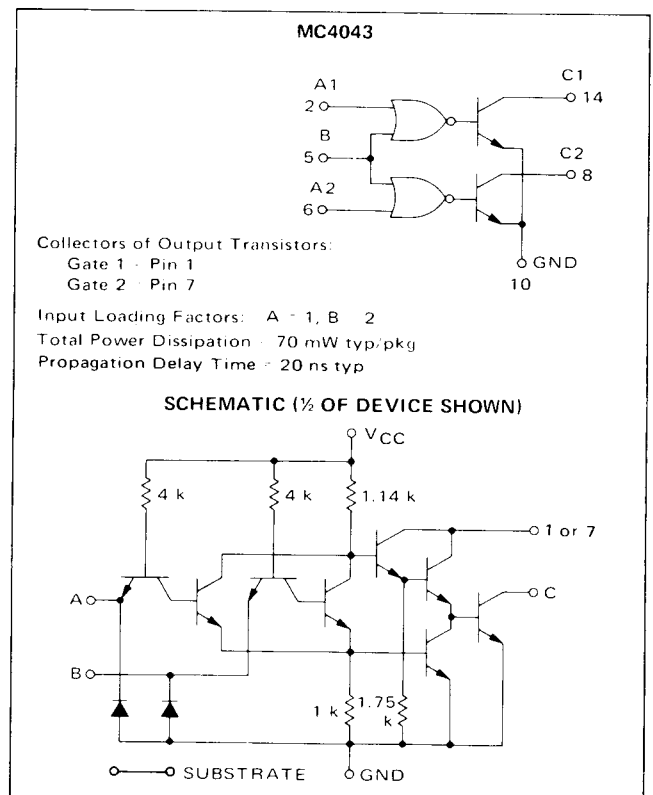
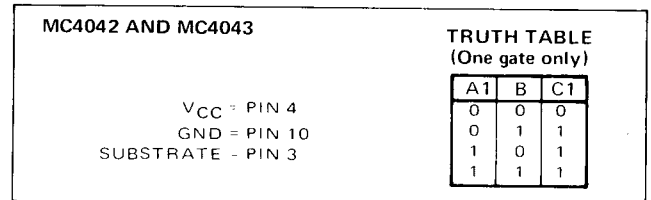
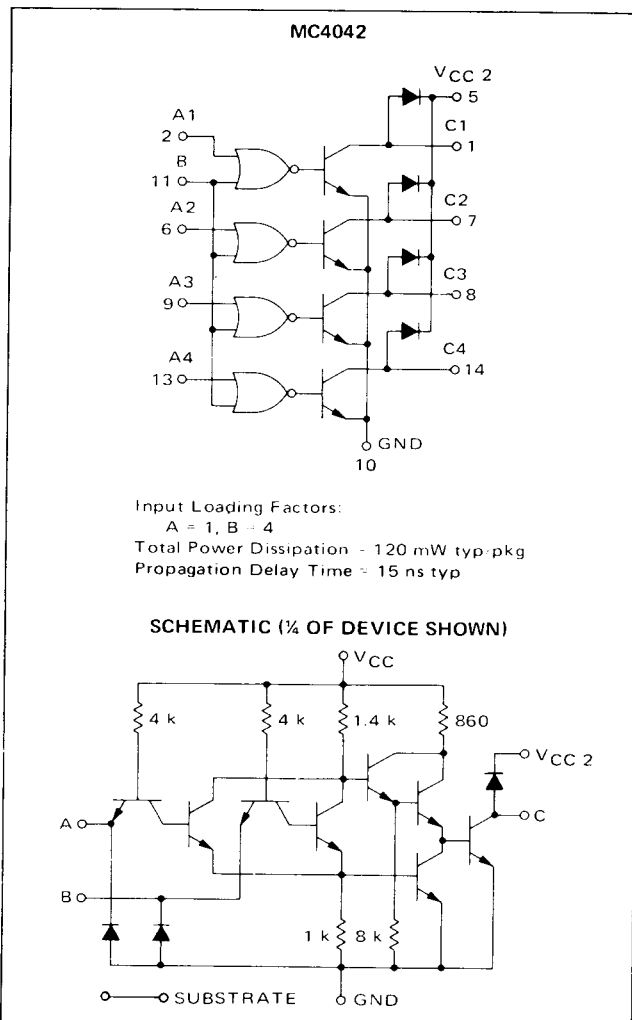

NON-INVERTING  
ONE-OF-EIGHT DECODER

**MC4348**  
**MC4048**

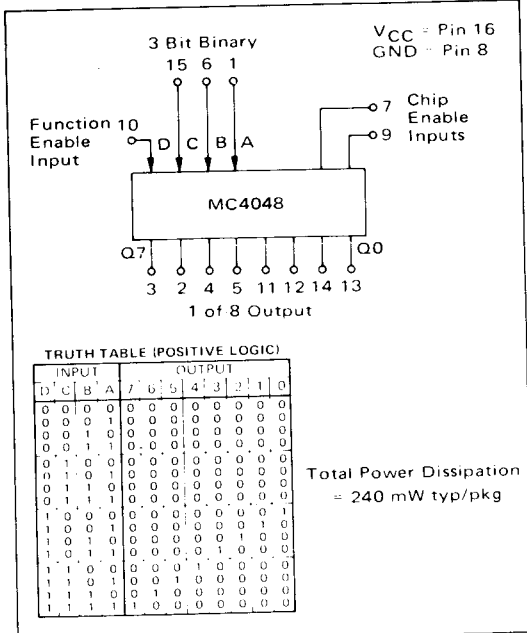

E	E	Q7	Q6	Q5	Q4	Q3	Q2	Q1	Q0
0	0	1	1	1	1	1	1	1	1
0	1	1	1	1	1	1	1	1	1
1	0	1	1	1	1	1	1	1	1
1	1	1	1	1	1	1	1	1	1

FUNCTION ENABLED

A 3-bit binary address selects the desired word for the 8-bit output, and the selected output goes to a logic "1". The function enable input, D, is useful for expansion of the decoding function. When D is a logic "0" all outputs are logic "0". A logic "1" on D produces a logic "1" on the selected output.

Features:

- Address times < 50 ns
- Outputs sink 16 mA
- Output capacitance < 7.0 pF @ 1.5 V

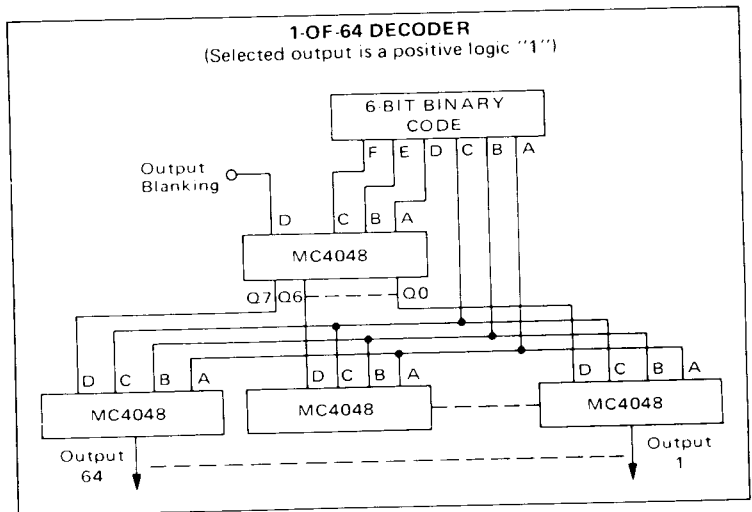

REPRESENTATIVE CIRCUIT SCHEMATIC

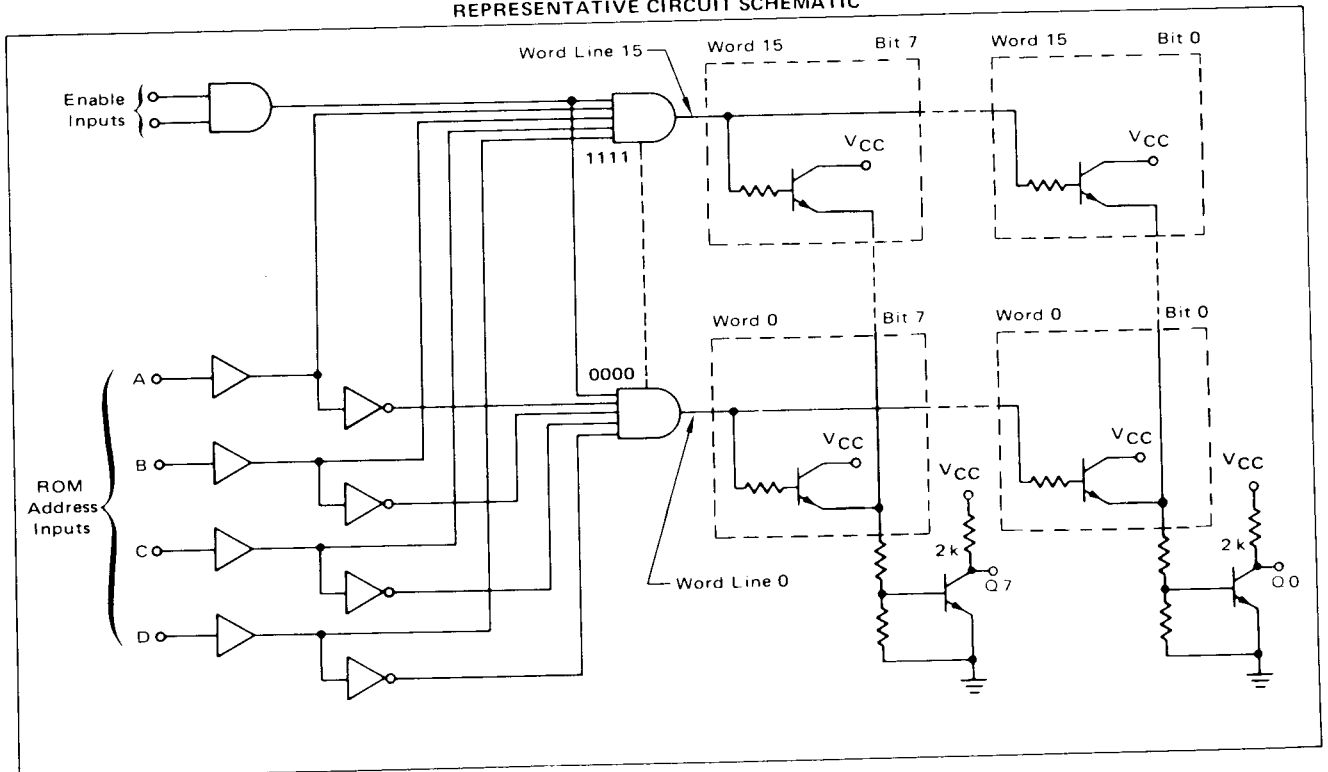

COUNTER-LATCH DECODER

**MC4350**  
**MC4050**

This monolithic integrated circuit combines the functions of a binary coded decimal counter, a four-bit latch, and a seven-segment decoder/driver. Designed primarily for counting applications such as frequency counters, the circuit contains a leading zero blanking feature activated through the Reset input. For this reason the MC4350/4050 is useful in systems using automatic decimal ranging and/or automatic time base selection. A Count Enable input gates the clock input without restrictions on the clock level and without false-clocking the counter. The Terminal Count is high driving the ninth count, allow-

ing synchronous or asynchronous counter operation when used in conjunction with the Count Enable input and external gating. The Counter Reset places the counter in a non-NBCD state, turning off the output driver transistors when transferred through the latch and decoded. The latch section admits information while the Latch Strobe is high and latches the data on the negative edge of the strobe. The seven-segment decoder/driver provides up to 40 mA drive capability for displays requiring current sinking in the active mode. A lamp blanking input provides intensity modulation. A lamp test feature is also available.

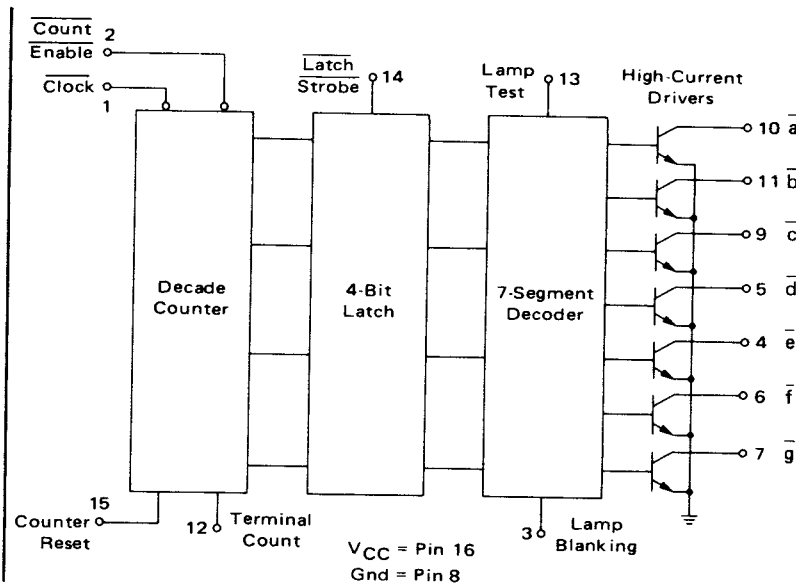

SEGMENT IDENTIFICATION

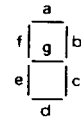

Total Power Dissipation = 450 mW typ/package  
Maximum Toggle Frequency = 40 MHz typ

FUNCTIONAL TRUTH TABLE

FUNCTION	INPUT						OUTPUT							
	CLOCK	CE	CR	LST	LT	LB	TC	a	b	c	d	e	f	g
Lamp Test	X	X	X	X	1	X	—	0	0	0	0	0	0	0
Lamp Blanking	X	X	X	X	0	1	—	1	1	1	1	1	1	1
Reset	X	X	1	1	0	0	0	1	1	1	1	1	1	1
Enable	P	1	0	1	0	0	0	1	1	1	1	1	1	1
State Sequence	1	P1	0	0	1	0	0	0	1	0	0	1	1	1
	2	P2	0	0	1	0	0	0	0	0	1	0	0	1
	3	P3	0	0	1	0	0	0	0	0	0	0	1	0
	4	P4	0	0	1	0	0	0	1	0	0	1	1	0
	5	P5	0	0	1	0	0	0	0	1	0	0	1	0
	6	P6	0	0	1	0	0	0	0	1	0	0	0	0
	7	P7	0	0	1	0	0	0	0	0	0	1	1	1
	8	P8	0	0	1	0	0	0	0	0	0	0	0	0
	9	P9	0	0	1	0	0	1	0	0	0	0	1	0
	0	P10	0	0	1	0	0	0	0	0	0	0	0	0
	1	P11	0	0	1	0	0	0	1	0	0	1	1	1
Latch	P	0	0	0	0	0	0	1	0	0	1	1	1	

P = any number of pulses may be applied  
P<sub>n</sub> = n pulses on the Clock input  
X = Don't care

### FUNCTION DESCRIPTION

The MC4350/4050 is suited for driving incandescent seven-segment decimal indicators. In addition, only current limiting resistors are needed to allow driving hybrid LED's in the 2.4-volt per segment capability range with common-anode configuration. Use the MC4051 for monolithic LED arrays with common-cathode connection.

Logic "1" allows decoder to be driven directly from counter outputs. Logic "0" stores counter output data as it was immediately prior to "1" to "0" transition.

This input has no effect on the circuit if LT is at logic "1". With LT = logic "0", a logic "1" at this input turns off outputs  $\bar{a}$  thru  $\bar{g}$ ; a logic "0" allows  $\bar{a}$  thru  $\bar{g}$  to display normally.

Logic "1" resets counter to binary state 1010 (12). This turns all output transistors "off", providing automatic zero suppression. The next enabled Clock pulse advances counter to 0001.

Logic "1" turns outputs  $\bar{a}$  thru  $\bar{g}$  "on" regardless of other input states.

Logic "1" inhibits counting. Logic "0" enables counting.

Counter advances one state each time Clock changes from logic "1" to logic "0" if  $\overline{CE}$  and CR are both at logic "0".

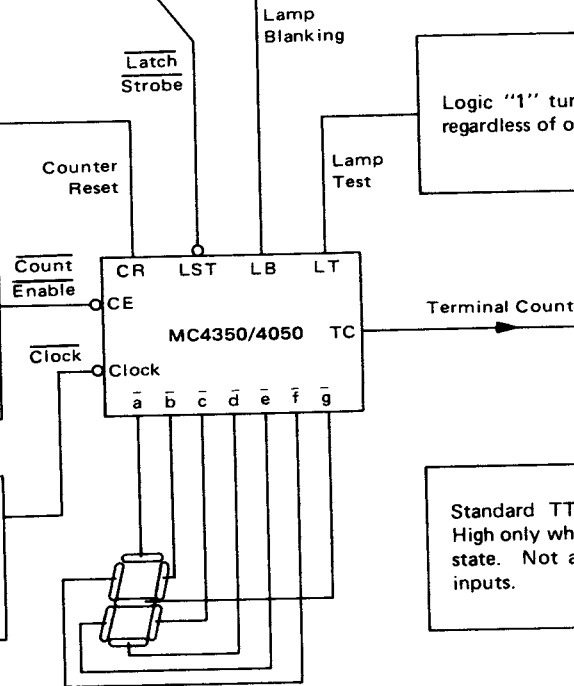

Standard TTL output (active pull-up). High only when counter is in 0110 (nine) state. Not affected by LB, LT, or LST inputs.

### OPERATING DETAILS

- $\overline{Count\ Enable}$  may be changed with  $\overline{Clock}$  either high or low.
- Counter Reset overrides  $\overline{Count\ Enable}$  and  $\overline{Clock}$ . It may be changed regardless of levels present at  $\overline{Count\ Enable}$  and  $\overline{Clock}$ .
- $\overline{Latch\ Strobe}$ , Lamp Blanking, and Lamp Test may be changed regardless of levels at  $\overline{Count\ Enable}$ ,  $\overline{Clock}$ , and Counter Reset.
- Refer to Timing Diagram if a logic "1" to "0" transition on  $\overline{Clock}$  can occur while levels are changing on  $\overline{Count\ Enable}$  or  $\overline{Latch\ Strobe}$ , or if a logic "0" to "1" transition of Counter Reset can occur simultaneously with a "0" to "1" transition of  $\overline{Latch\ Strobe}$ .
- Tie all unused inputs to ground except for  $\overline{Latch\ Strobe}$ , which must be returned to a logic "1" level if not used.
- Outputs  $\bar{a}$  thru  $\bar{g}$  are open-collector transistors capable of sinking 40 mA dc with outputs low, and sustaining 8.0 Vdc minimum (15 Vdc typical) with outputs high.



# MC4351 MC4051

This device is a monolithic MSI integrated circuit combining the functions of an NBCD counter, four-bit latch, and a seven-segment decoder/driver. The counter advances on the negative edge of the Clock, subject to control by the Enable input. The Serial Output is high driving the ninth count, allowing synchronous or asynchronous counter operation when used in conjunction with the Enable input and some external gating. The counter Reset places the counter in a non-NBCD state, turning off the output driver transistors when transferred through the latch and decoded. This feature gives automatic suppression of leading zeros in the display. The latch section admits information while the Strobe is high and latches the data on the neg-

ative edge of the strobe. The seven-segment decoder/driver is active high and will source up to 40 mA at a 10% duty cycle or 15 mA at a 100% duty cycle. A lamp blanking input is provided for intensity modulation. A lamp test feature is also available.

The output structure of this device is an open emitter-follower configuration whose equivalent circuit is a voltage source with a relatively small series resistance. Although this resistance increases when the output is grounded, the situation is potentially destructive to the device. When the outputs are in the high ("1") state, they should not be connected to ground through an impedance of less than 100 ohms.

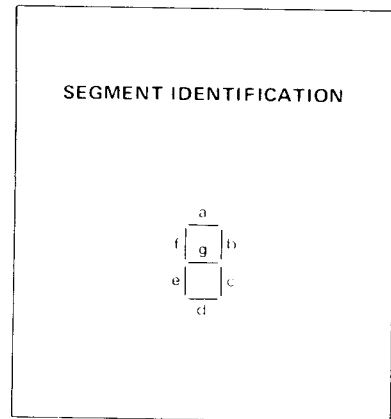
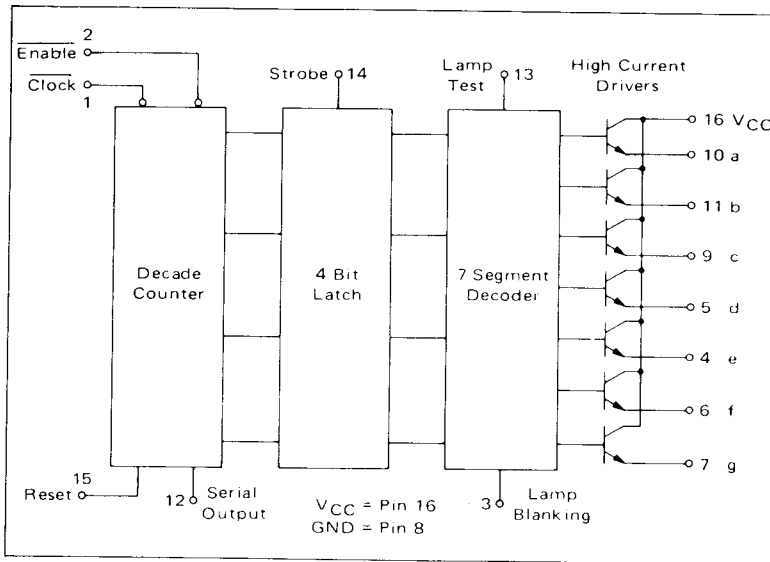

Total Power Dissipation = 450 mW typ/package  
Maximum Toggle Frequency = 35 MHz typ

FUNCTIONAL TRUTH TABLE

FUNCTION	INPUT						OUTPUT							
	C	E	R	S	LT	LB	S <sub>out</sub>	a	b	c	d	e	f	g
Lamp Test	X	X	X	X	1	X		1	1	1	1	1	1	1
Lamp Blanking	X	X	X	X	0	1		0	0	0	0	0	0	0
Reset	X	X	1	1	0	0	0	0	0	0	0	0	0	0
Enable	P	1	0	1	0	0	0	0	0	0	0	0	0	0
State Sequence	1	P1	0	0	1	0	0	0	0	1	1	0	0	0
	2	P2	0	0	1	0	0	0	1	1	0	1	1	0
	3	P3	0	0	1	0	0	0	1	1	1	1	0	1
	4	P4	0	0	1	0	0	0	0	1	1	1	0	1
	5	P5	0	0	1	0	0	0	1	0	1	1	0	1
	6	P6	0	0	1	0	0	0	1	0	1	1	1	1
	7	P7	0	0	1	0	0	0	1	1	1	0	0	0
	8	P8	0	0	1	0	0	1	1	1	1	1	1	1
	9	P9	0	0	1	0	0	0	1	1	1	1	0	1
	0	P10	0	0	1	0	0	0	1	1	1	1	1	0
	1	P11	0	0	1	0	0	0	0	0	1	1	0	0
Latch	P	0	0	0	0	0	0	0	1	1	0	0	0	

P = any number of pulses may be applied  
P<sub>n</sub> = n pulses on the Clock input  
X = Don't care

DUAL DECADE COUNTER

**MC4352**  
**MC4052**

DUAL HEXADECIMAL COUNTER

**MC4353**  
**MC4053**

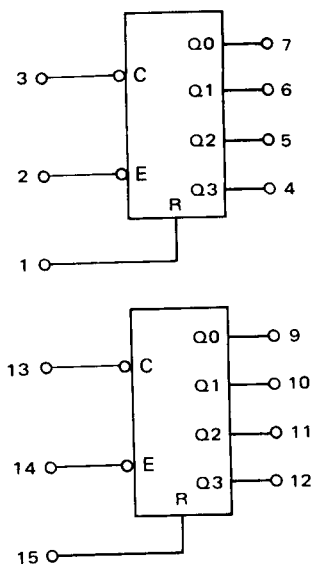

V<sub>CC</sub> = Pin 16  
Gnd = Pin 8

Reset  
Enable

Total Power Dissipation = 350 mW typ/pkg  
Maximum Toggle Frequency = 40 MHz typ

The MC4352/4052 and MC4353/4053 consist of two independent up counters. The counters advance on the negative edge of the clock when the enable input is low. The count is held when the enable input is high. The enable input should not be taken to the high level while the clock is high, as erroneous triggering can result. A high level on the reset input places the counter in the 0000 state, overriding the clock and enable inputs. As charge control steering is utilized in this design, capacitive loading on the outputs should be kept at a minimum.

FUNCTIONAL TRUTH TABLE

INPUT			MC4352/4052 OUTPUT				MC4353/4053 OUTPUT			
R	$\bar{E}$	$\bar{C}$	Q3	Q2	Q1	Q0	Q3	Q2	Q1	Q0
1	X	X	0	0	0	0	0	0	0	0
0	1	P	0	0	0	0	0	0	0	0
0	0	P1	0	0	0	1	0	0	0	1
0	0	P2	0	0	1	0	0	0	1	0
0	0	P3	0	0	1	1	0	0	1	1
0	0	P4	0	1	0	0	0	1	0	0
0	0	P5	0	1	0	1	0	1	0	1
0	0	P6	0	1	1	0	0	1	1	0
0	0	P7	0	1	1	1	0	1	1	1
0	0	P8	1	0	0	0	1	0	0	0
0	0	P9	1	0	0	1	1	0	0	1
0	0	P10	0	0	0	0	1	0	1	0
0	0	P11	0	0	0	1	1	0	1	1
0	0	P12	Above Sequence Repeats				1	1	0	0
0	0	P13					1	1	0	1
0	0	P14					1	1	1	0
0	0	P15					1	1	1	1
0	0	P16					0	0	0	0
0	0	P17	0	0	0	1				

P = any number of pulses may be applied  
P<sub>n</sub> = n pulses on the Clock input  
X = Don't Care



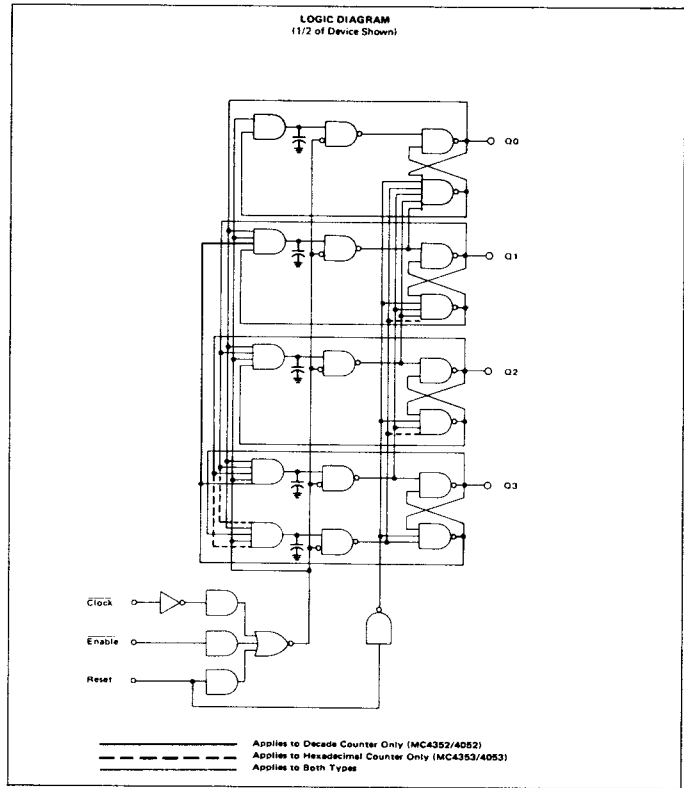

**FUNCTIONAL DIAGRAMS**

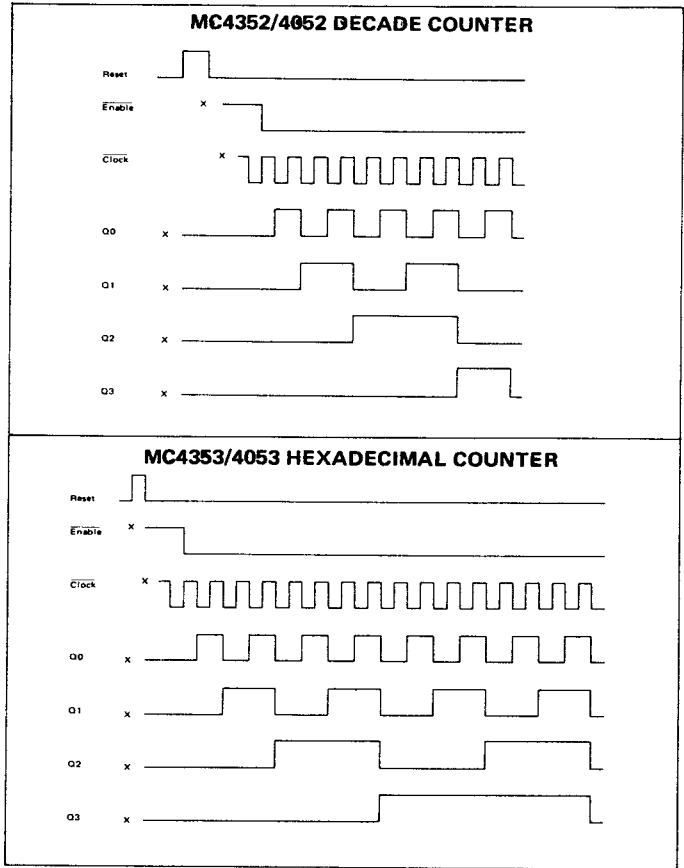

DUAL DECADE UP/DOWN COUNTER

**MC4354**

**MC4054**

DUAL BINARY UP/DOWN COUNTER

**MC4355**

**MC4055**

These devices are presettable, synchronous (clocked) up/down counters. The MC4354/4054 is a decade counter consisting of two separate but cascaded counters. One counter counts the least significant decade, and the other the most significant decade. The counter counts to 1001 1001, or 99, before resetting to 0000 0000. The MC4355/4055 is a binary counter consisting of two separate hexadecimal counters which are cascaded. This counter is essentially an 8-bit binary counter which counts to 1111 1111, or 255, before resetting to 0000 0000.

Both counters in a package are preset by means of a high level on the Preset (P) input. (The Preset input overrides all synchronous inputs: Clock,  $\overline{SEI}$ , and  $\overline{UE}$ .) Information is then loaded into the least significant counter thru inputs D0, D1, D2 and D3, and into the most significant counter thru inputs D0', D1', D2', and D3'.

The Up/Down input determines the mode of counting: up when high, down when low.

Two Enable inputs are part of these circuits. The Unit Enable ( $\overline{UE}$ ) affects only the counters within a specific package. The Serial Enable ( $\overline{SEI}$ ) not only affects a parti-

cular package, but also furnishes a signal at the Serial Enable Output ( $\overline{SEO}$ ) for control of succeeding packages in a counter chain. A high input to  $\overline{SEI}$  forces  $\overline{SEO}$  high. When  $\overline{SEI}$  is low,  $\overline{SEO}$  decodes the terminal state of the counter, independently from the  $\overline{UE}$  control, when the counters are in the terminal state. (Terminal state is defined as 0000 0000 when counting down, and as 1111 1111 (256) for the binary counter and 1001 1001 (99) for the decade counter when counting up.)

Both the Serial Enable ( $\overline{SEI}$ ) and the Unit Enable ( $\overline{UE}$ ) must be low for the counter to be clocked. Logic levels on both of these lines must be settled prior to the trailing edge of the Clock, and must remain stable while the Clock is low.

The count state may change only on the leading edge of a Clock pulse. Any changes on the control inputs (Up/Down,  $\overline{SEI}$ , and  $\overline{UE}$ ) must be made while the Clock is high.

Counting data is read out on Q0 thru Q3 for the least significant counter, and Q0' thru Q3' for the most significant counter.

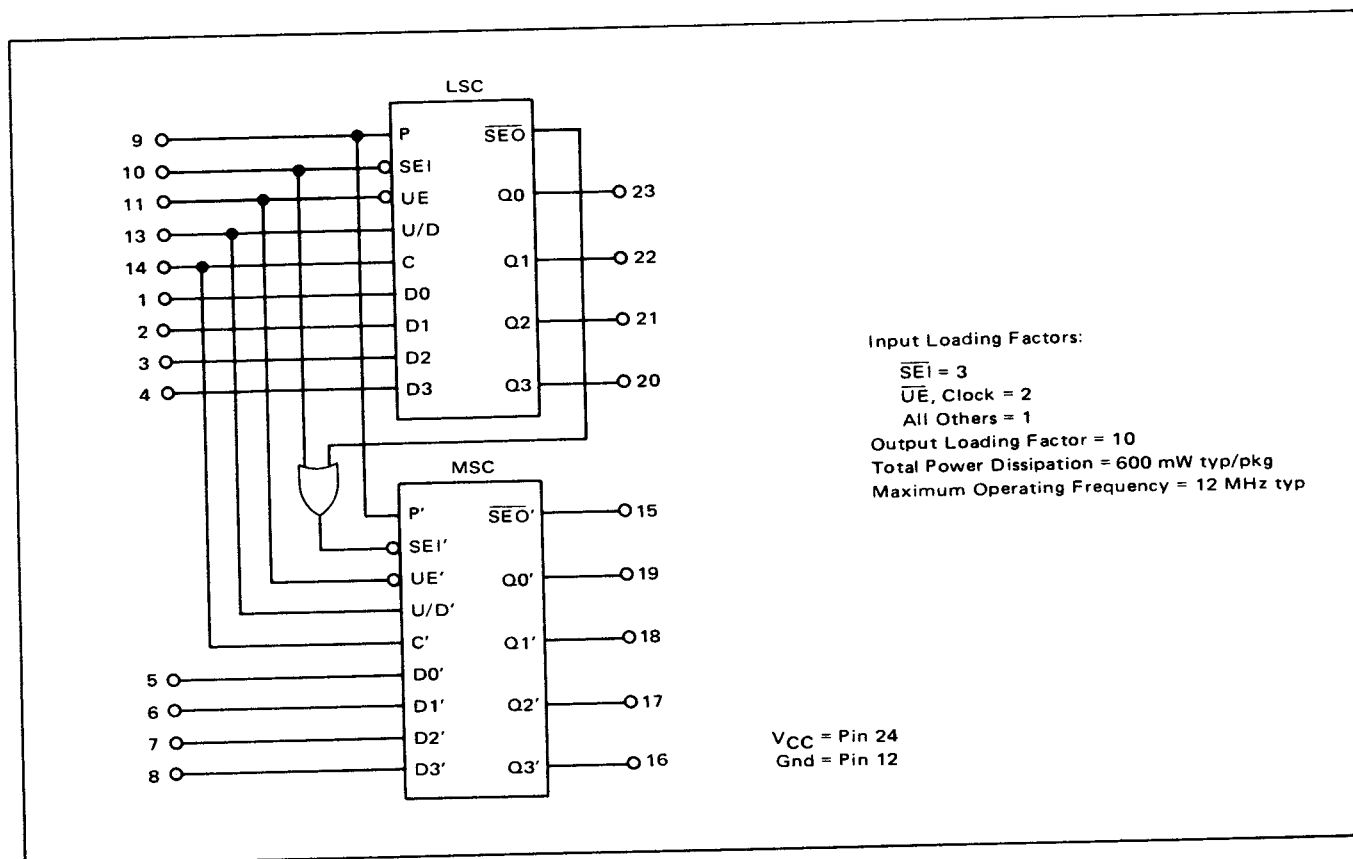

MC4354/4054

COUNT	INPUTS											OUTPUTS										
	C	UE	SEI	U/D	P	TENS				UNITS			TENS				UNITS				SE0	
						D3'	D2'	D1'	D0'	D3	D2	D1	D0	Q3'	Q2'	Q1'	Q0'	Q3	Q2	Q1		Q0
0	1	1	0	1	1	0	0	0	0	0	0	0	0	0	0	0	0	0	0	0	0	1
1	0	1	0	1	1	X	0	0	0	0	0	0	0	0	0	0	0	0	0	0	0	1
2	A	1	0	1	1	X	X	X	X	X	X	X	X	X	X	X	X	X	X	X	X	1
3	1	1	0	1	1	X	X	X	X	X	X	X	X	X	X	X	X	X	X	X	X	1
4	1	1	0	1	1	X	X	X	X	X	X	X	X	X	X	X	X	X	X	X	X	1
5	0	0	1	1	1	X	X	X	X	X	X	X	X	X	X	X	X	X	X	X	X	1
6	A	0	1	1	1	X	X	X	X	X	X	X	X	X	X	X	X	X	X	X	X	1
7	1	0	0	1	1	X	X	X	X	X	X	X	X	X	X	X	X	X	X	X	X	1
8	A	0	0	1	1	X	X	X	X	X	X	X	X	X	X	X	X	X	X	X	X	1
9	A	0	0	1	1	X	X	X	X	X	X	X	X	X	X	X	X	X	X	X	X	1
10	A	0	0	1	1	X	X	X	X	X	X	X	X	X	X	X	X	X	X	X	X	1
11	A	0	0	1	1	X	X	X	X	X	X	X	X	X	X	X	X	X	X	X	X	1
12	A	0	0	1	1	X	X	X	X	X	X	X	X	X	X	X	X	X	X	X	X	1
...	84A	0	0	1	1	X	X	X	X	X	X	X	X	X	X	X	X	X	X	X	X	1
97	A	0	0	1	1	X	X	X	X	X	X	X	X	X	X	X	X	X	X	X	X	1
98	A	0	0	1	1	X	X	X	X	X	X	X	X	X	X	X	X	X	X	X	X	1
99	A	0	0	1	1	X	X	X	X	X	X	X	X	X	X	X	X	X	X	X	X	1
00	1	0	0	1	1	X	X	X	X	X	X	X	X	X	X	X	X	X	X	X	X	0
00	1	0	0	0	0	X	X	X	X	X	X	X	X	X	X	X	X	X	X	X	X	0
00	0	0	0	0	0	X	X	X	X	X	X	X	X	X	X	X	X	X	X	X	X	0
99	A	0	0	0	0	X	X	X	X	X	X	X	X	X	X	X	X	X	X	X	X	0
98	A	0	0	0	0	X	X	X	X	X	X	X	X	X	X	X	X	X	X	X	X	0
97	A	0	0	0	0	X	X	X	X	X	X	X	X	X	X	X	X	X	X	X	X	0
...	94A	0	0	0	0	X	X	X	X	X	X	X	X	X	X	X	X	X	X	X	X	0
02	A	0	0	0	0	X	X	X	X	X	X	X	X	X	X	X	X	X	X	X	X	0
01	A	0	0	0	0	X	X	X	X	X	X	X	X	X	X	X	X	X	X	X	X	0
00	1	0	0	0	0	X	X	X	X	X	X	X	X	X	X	X	X	X	X	X	X	0
00	1	0	0	0	0	X	X	X	X	X	X	X	X	X	X	X	X	X	X	X	X	0
00	1	0	0	0	0	X	X	X	X	X	X	X	X	X	X	X	X	X	X	X	X	0
97	0	0	0	0	1	1	0	0	1	0	1	1	1	1	1	1	1	1	1	1	1	0
97	0	0	0	0	0	1	0	0	1	0	1	1	1	1	1	1	1	1	1	1	1	0
96	A	0	0	0	0	X	X	X	X	X	X	X	X	X	X	X	X	X	X	X	X	1
95	A	0	0	0	0	X	X	X	X	X	X	X	X	X	X	X	X	X	X	X	X	1
0	0	0	0	0	1	0	0	0	0	0	0	0	0	0	0	0	0	0	0	0	0	0

X = Don't Care  
 \*Outputs count from 12 to 96 during these 84 clock pulses.  
 \*\*Outputs count from 97 to 13 during these 94 clock pulses.



MC4355/4055

The MC4355/4055 works in the same manner as the MC4354/4054 except the least significant counter counts to 1111 before clocking the most significant counter, and both counters count to 1111 1111 or 255 before resetting to 0.

NBCD ADDER

**MC4356**  
**MC4056**

Input Loading Factor:  $C_{in} = 5$   
 $A, B = 2$   
 Output Loading Factor = 10  
 Total Power Dissipation = 300 mW typ/pkg  
 Propagation Delay Time = 30 ns typ

The MC4356/4056 adds two 4-bit numbers in NBCD (Natural Binary Coded Decimal) format. Sum and Carry outputs are generated, also in NBCD code.

NBCD adders are used in such applications as machine controls (to avoid conversion of NBCD data to binary numbers), and in phase-locked loops together with programmable counters. This adder can also subtract, when coupled to a 9's complement logic function.

TRUTH TABLE\*

INPUT									OUTPUT				
A4	A3	A2	A1	B4	B3	B2	B1	$C_{in}$	$C_{out}$	S4	S3	S2	S1
0	0	0	0	0	0	0	0	0	0	0	0	0	0
0	0	0	0	0	0	0	0	1	0	0	0	0	1
0	1	0	0	0	1	0	0	0	0	1	0	0	0
0	1	0	0	0	1	0	0	1	0	0	1	0	1
0	1	1	1	0	1	0	0	0	1	0	0	0	1
0	1	1	1	0	1	0	0	1	1	0	0	1	0
1	0	0	1	1	0	0	1	1	1	1	0	0	1
1	0	0	1	0	0	0	0	1	1	0	0	0	0
1	0	0	1	0	0	0	1	0	1	0	0	0	0

\* This is only a partial truth table and is provided to illustrate the logic function of this device.

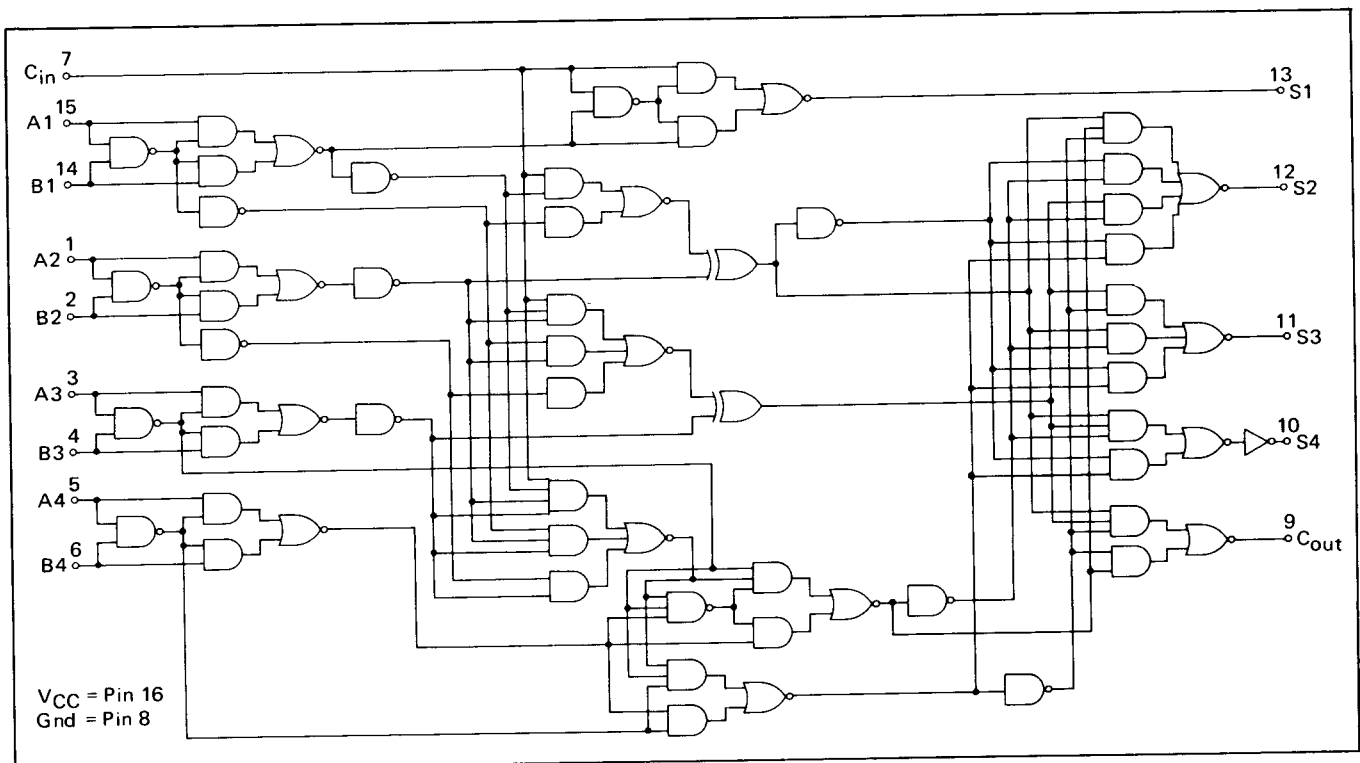

NINES COMPLEMENT/ZERO ELEMENT

MC4358

MC4058

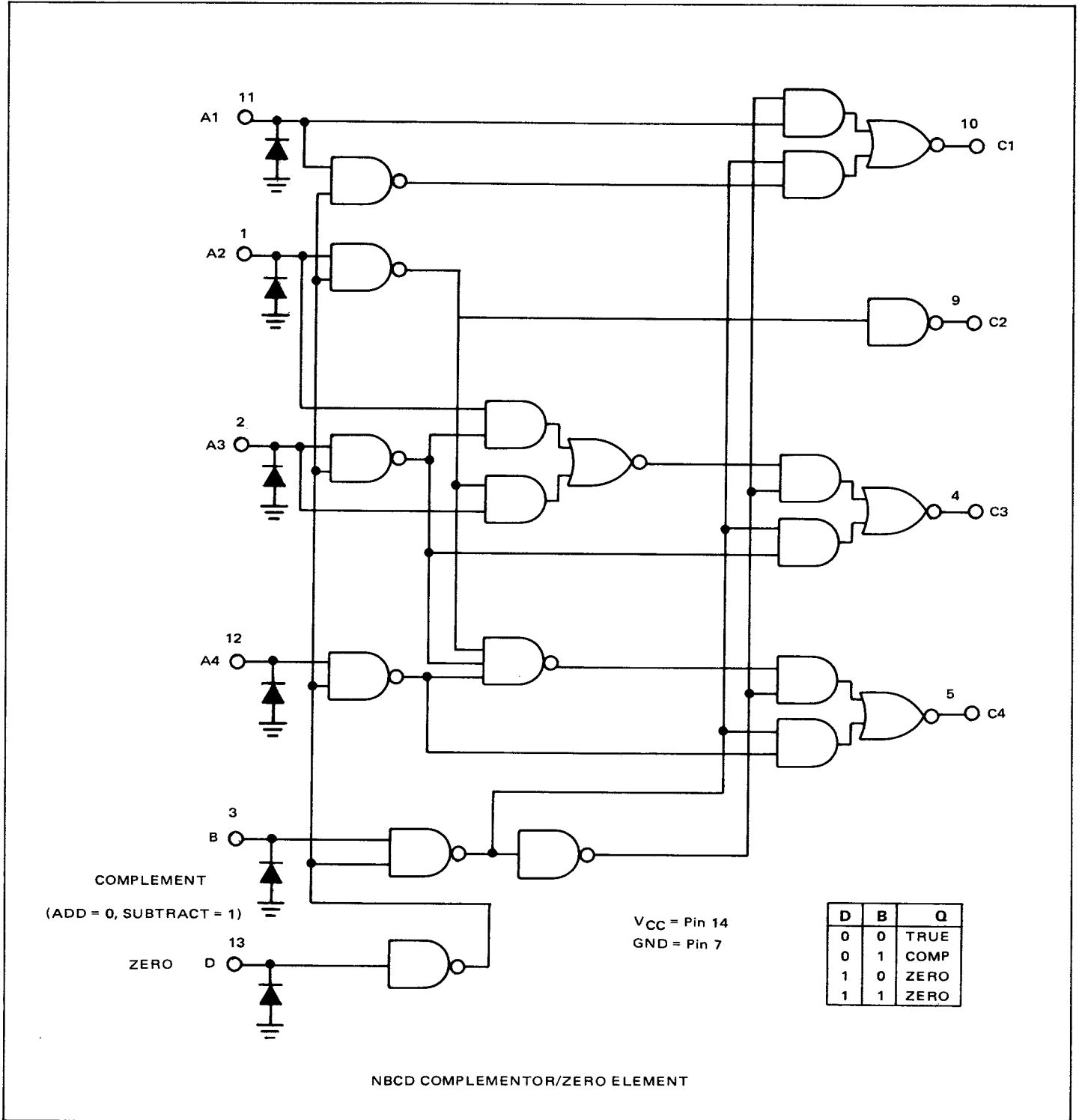

BUS TRANSFER SWITCH

MC4360

MC4060

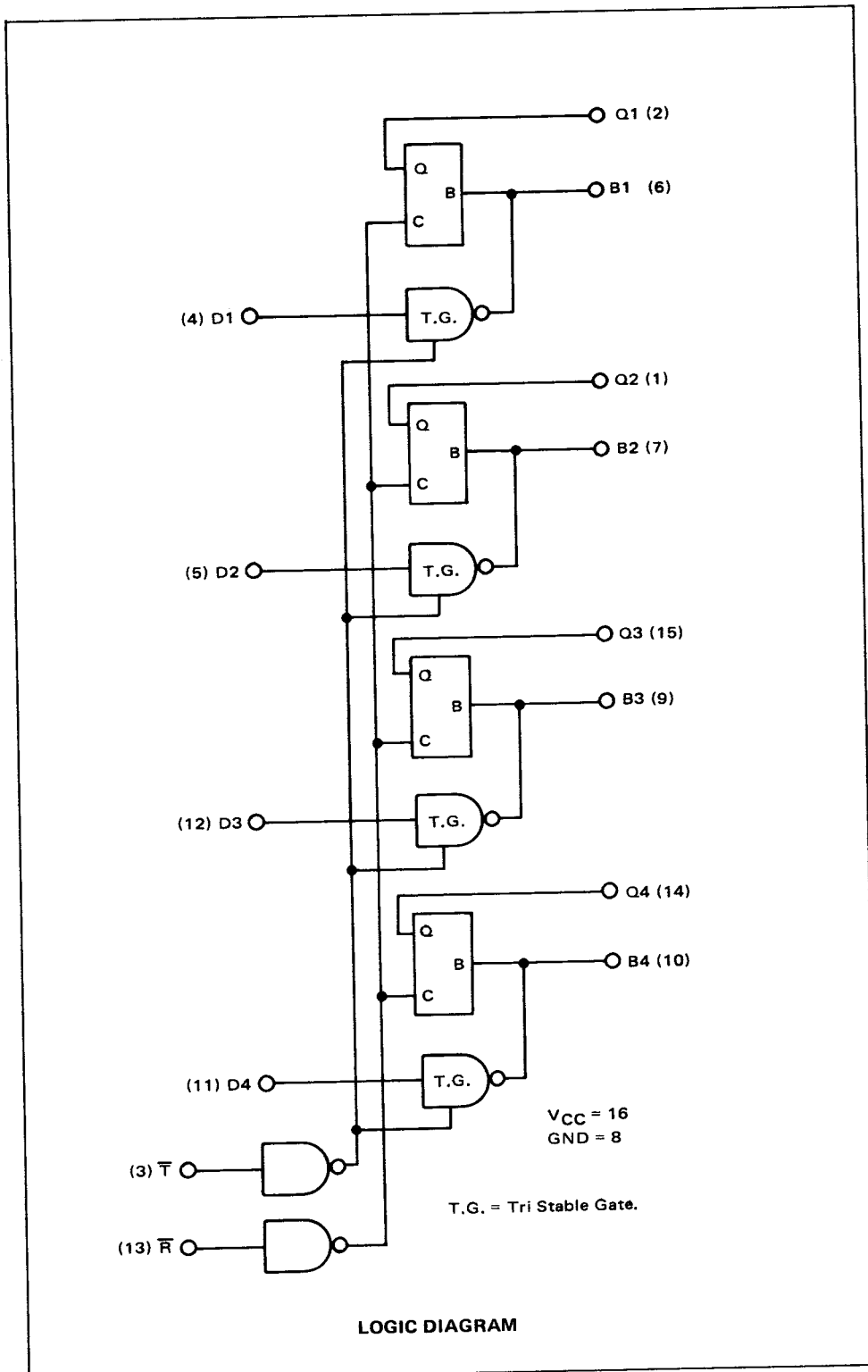



DUAL  
MAJORITY LOGIC GATE

**MC4362**  
**MC4062**

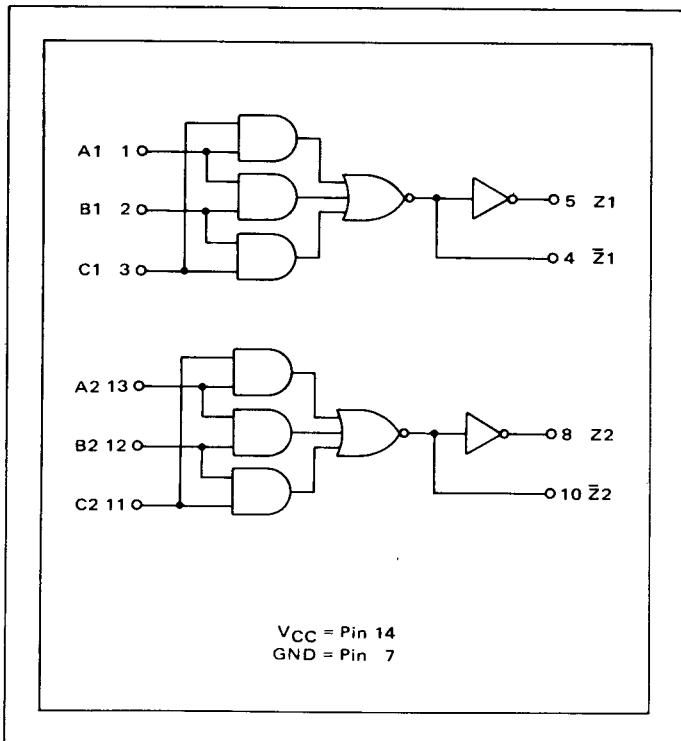

This integrated circuit offers the designer additional versatility in logic design. When any two or all three of the inputs are raised to the "1" level, the output goes to the "1" level. The output, Z, and its complement,  $\bar{Z}$ , are both available.

INPUT			OUTPUT	
A	B	C	Z	$\bar{Z}$
0	0	0	0	1
0	0	1	0	1
0	1	0	0	1
0	1	1	1	0
1	0	0	0	1
1	0	1	1	0
1	1	0	1	0
1	1	1	1	0

Total Power Dissipation = 75 mW typ/pkg  
Propagation Delay Time = 20 ns typ (Z Output)  
11 ns typ ( $\bar{Z}$  Output)

**CIRCUIT SCHEMATIC**  
(1/2 OF DEVICE SHOWN)

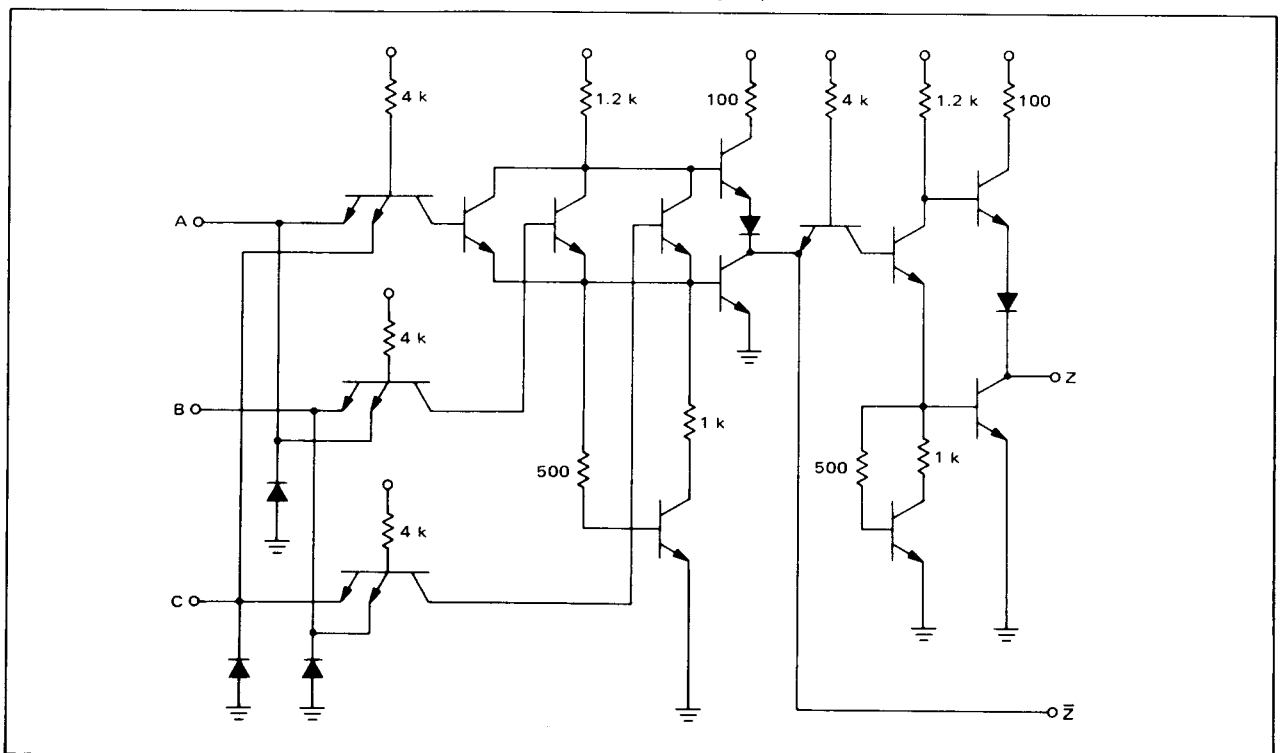

# 64-BIT RANDOM ACCESS MEMORY

## MC4364

## MC4064

### 64-BIT RANDOM ACCESS MEMORY

The MC4364/4064 is a 64-Bit random access memory organized as a 16-word by 4-bit array. Schottky-diode-clamped transistors are utilized to obtain fast switching speeds, and Schottky clamp diodes are used on all inputs to provide minimum line reflection. The high speed of this memory makes it ideal in scratch pad operation.

Address decoding is incorporated in the circuit providing 1-of-16 decoding from the four address lines. Separate Data In and Data Out lines, together with a Chip Enable provide for easy expansion of memory capacity. A Write is provided to enable data presented at the Data In lines to be entered at the addressed storage cells. When writing, Data Out is the complement of the Data In.

The open-collector output transistors are also Schottky barrier devices and combine greater current sinking capability with lower leakage currents, thereby increasing the wire-OR capability of these devices.

- Both Minimum and Maximum Access Times Specified
- Binary Addressing
- Chip Enable for Memory Expansion
- Outputs May Be "Wire ORed"
- Logic Levels Compatible with MDTL and All MTTL Families
- Low-Voltage Input Clamp Diodes
- Access Time < 60 ns
- Power Dissipation Typically 6 mW/bit
- Outputs Sink 15 mA

### PIN ASSIGNMENT

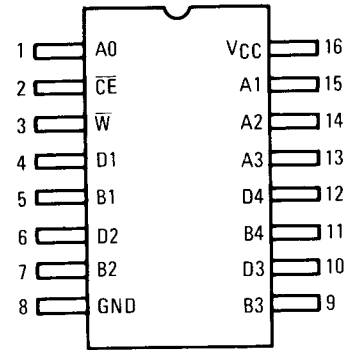

### TRUTH TABLE

$\bar{W}$	D	$\bar{CE}$	DATA OUT
0	0	X	1
0	1	X	0
1	X	0	Read
1	X	1	1

X = Don't Care

### MAXIMUM RATINGS

Rating	Symbol	Value	Unit
Supply Voltage	$V_{CC}$	7.0	Vdc
Input Voltage - All Inputs	$V_{in}$	5.5	Vdc
Output Voltage - All Outputs	$V_D$	5.5	Vdc
Output Current	$I_D$	100	mAdc
Operating Temperature Range - MCM4364L - MCM4064L	$T_A$	-55 to +125 0 to +85	$^{\circ}C$
Thermal Resistance, Junction to Ambient (Typical)	$\theta_{JA}$	110	$^{\circ}C/W$
Thermal Resistance, Junction to Case (Typical)	$\theta_{JC}$	60	$^{\circ}C/W$
Storage Temperature Range	$T_{stg}$	-65 to +160	$^{\circ}C$

### BLOCK DIAGRAM

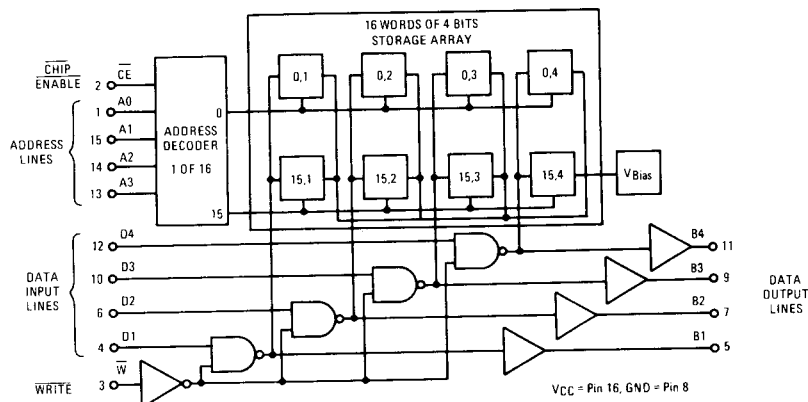

DUAL MOS-TO-TTL  
LEVEL TRANSLATOR  
WITH THREE-STATE OUTPUT

**MC4368**  
**MC4068**

The MC4368/4068 is a dual MOS-to-TTL translator designed to sense the open-drain output current of MOS memories such as the 1103 type. The device has several features that greatly enhance system performance and reduce package count: (1) no external components are required for interfacing, (2) current rather than voltage is sensed, (3) latch capabilities are

available, (4) the device has bus driver capabilities, (5) the three-state output feature allows a number of outputs to be tied together on a common data bus without sacrificing the speed of the totem pole output, and (6) only the standard TTL 5-volt power supply is required.

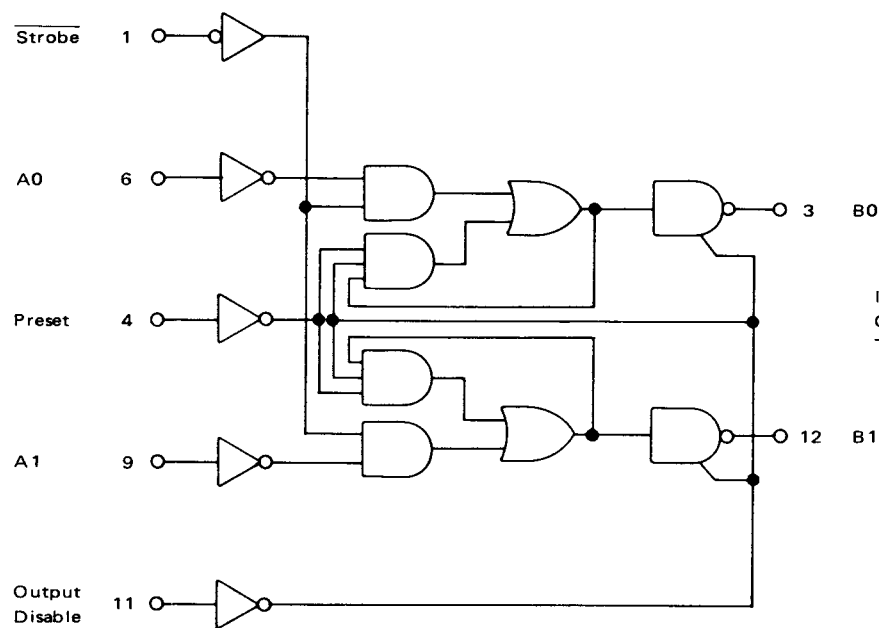

A0 and A1 are current sensing inputs.

For maximum noise suppression, also connect pins 5, 8 and 10 to ground (they are internally connected to substrate).

V<sub>CC</sub> = Pin 14  
Gnd = Pin 7

**TRUTH TABLE**

DIS	$\overline{ST}$	P	A0	A1	B0	B1
V <sub>I</sub> L <sub>T</sub>	V <sub>I</sub> H <sub>T</sub>	V <sub>I</sub> L <sub>T</sub>	I <sub>S</sub> 2	I <sub>S</sub> 2	V <sub>O</sub> L	V <sub>O</sub> L
V <sub>I</sub> L <sub>T</sub>	V <sub>I</sub> H <sub>T</sub>	V <sub>I</sub> H <sub>T</sub>	I <sub>S</sub> 2	I <sub>S</sub> 2	V <sub>O</sub> H	V <sub>O</sub> H
V <sub>I</sub> L <sub>T</sub>	V <sub>I</sub> H <sub>T</sub>	V <sub>I</sub> L <sub>T</sub>	I <sub>S</sub> 2	I <sub>S</sub> 2	V <sub>O</sub> H	V <sub>O</sub> H
V <sub>I</sub> L <sub>T</sub>	V <sub>I</sub> H <sub>T</sub>	V <sub>I</sub> L <sub>T</sub>	I <sub>S</sub> 1	I <sub>S</sub> 1	V <sub>O</sub> H	V <sub>O</sub> H
V <sub>I</sub> L <sub>T</sub>	V <sub>I</sub> L <sub>T</sub>	V <sub>I</sub> L <sub>T</sub>	I <sub>S</sub> 1	I <sub>S</sub> 1	V <sub>O</sub> L	V <sub>O</sub> L
V <sub>I</sub> L <sub>T</sub>	V <sub>I</sub> H <sub>T</sub>	V <sub>I</sub> L <sub>T</sub>	I <sub>S</sub> 1	I <sub>S</sub> 1	V <sub>O</sub> L	V <sub>O</sub> L
V <sub>I</sub> L <sub>T</sub>	V <sub>I</sub> H <sub>T</sub>	V <sub>I</sub> L <sub>T</sub>	I <sub>S</sub> 2	I <sub>S</sub> 2	V <sub>O</sub> L	V <sub>O</sub> L
V <sub>I</sub> H <sub>T</sub>	V <sub>I</sub> L <sub>T</sub>	V <sub>I</sub> L <sub>T</sub>	I <sub>S</sub> 1	I <sub>S</sub> 1	H**	H**
V <sub>I</sub> H <sub>T</sub>	V <sub>I</sub> H <sub>T</sub>	V <sub>I</sub> H <sub>T</sub>	I <sub>S</sub> 1	I <sub>S</sub> 1	L**	L**

Ground pins 5, 7, 8, and 10.

\*Outputs connected to V<sub>CC</sub> thru 470 ohm resistor,  
H = 4.88 V min.

\*\*Outputs connected to ground thru 220 ohm resistor,  
L = 55 mV max.

CIRCUIT SCHEMATIC  
(1/2 of Device and Common Inputs Shown)

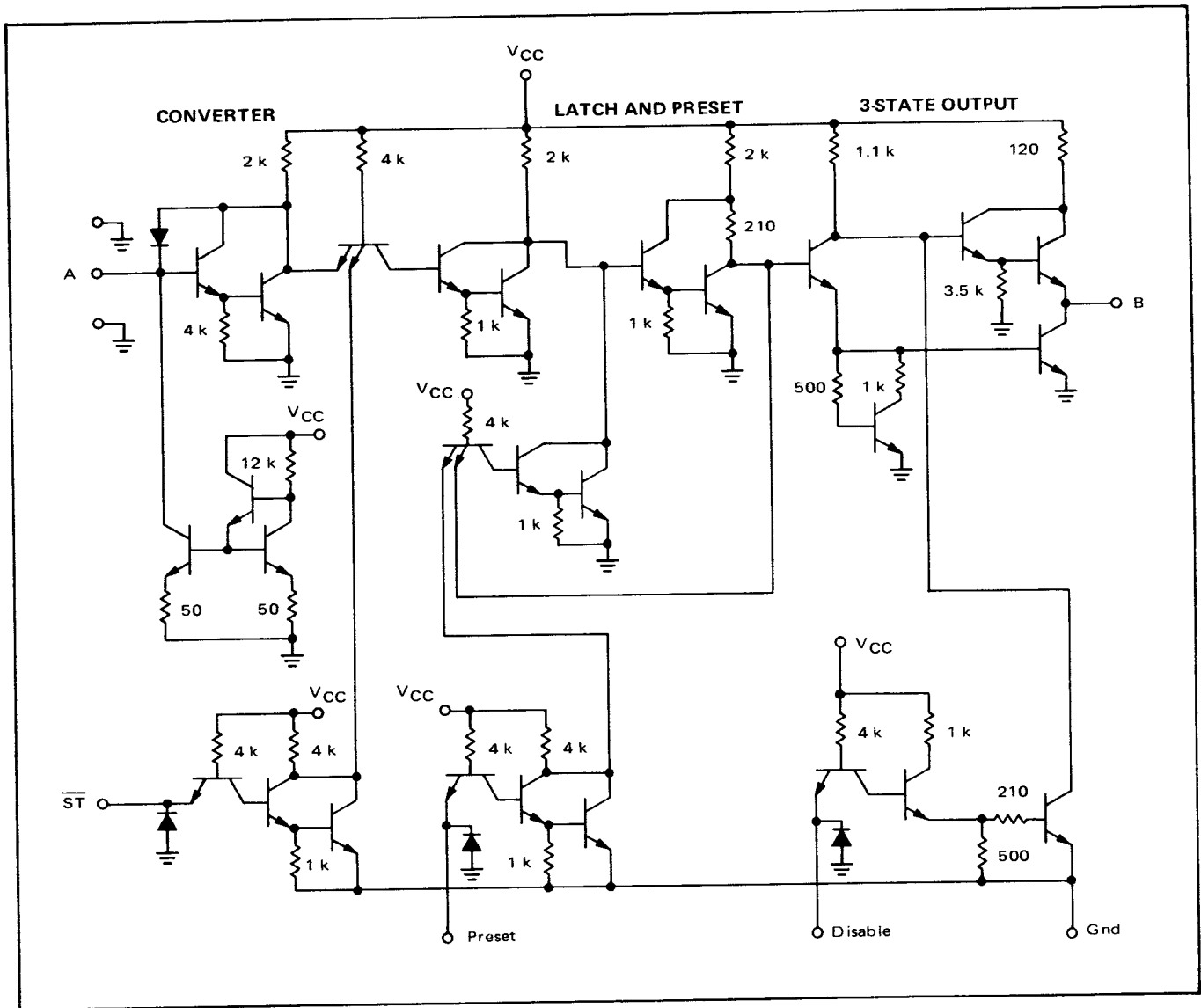

OPERATING CHARACTERISTICS

The MC4368/4068 is divided into three basic functions: (1) conversion of the MOS cell current to TTL voltage levels, (2) latching, and (3) coupling to the data bus.

The converter uses a darlington with negative feedback which provides a low input impedance and a fast recovery of the cell data line from noise. A fixed current logic threshold is provided by a sense amplifier arrangement. This threshold is nominally equal to one half of the minimum cell output current and is relatively unaffected by changes in temperature and power supply voltage. Ground pins are provided on each side of the current inputs. These

effectively isolate the sensitive inputs from transients.

The latch contains two darlington NANDs which are ORed into another darlington. One NAND is used to strobe the converted MOS cell output into the latch and the other provides feedback for the latch and the preset function.

The latch is then coupled to the output data bus via a three-state output, which allows a number of these outputs to be tied together on a common data bus without sacrificing the speed of the totem pole output.