



DELTA ELECTRONICS, INC.  
252, SHANGYING ROAD, GUISHAN INDUSTRIAL ZONE,  
TAOYUAN CITY 33341, TAIWAN

TEL : 886-(0)3-3591968  
FAX : 886-(0)3-3591991

## STATEMENT OF DEVIATION

NONE

DESCRIPTION:

DELTA ELECTRONICS, INC.  
 252, SHANGYING ROAD, GUISHAN INDUSTRIAL ZONE,  
 TAOYUAN CITY 33341, TAIWAN

TEL : 886-(0)3-3591968  
 FAX : 886-(0)3-3591991

## Specification For Approval

Customer : STD

Description : DC FAN

Customer P/N : \_\_\_\_\_ rev. : \_\_\_\_\_

Delta model no. : GFB0812ES-E Delta Safety Model No.: NA

Sample revision. : 00 Issue no.: \_\_\_\_\_

Sample issue date : MAY.13 2020 Quantity : \_\_\_\_\_

### 1. SCOPE:

THIS SPECIFICATION DEFINES THE ELECTRICAL AND MECHANICAL CHARACTERISTICS OF THE DC BRUSHLESS AXIAL FLOW FAN.

### 2. CHARACTERS:

ITEM	DESCRIPTION	
RATED VOLTAGE	12V	
OPERATION VOLTAGE	10.8 - 13.2 VDC	
INPUT CURRENT OF FREE AIR(AVG)	4.50 (MAX. 5.40 ) A CURRENT ON LABEL : 9.60A	
INPUT POWER (AVG.)	54.00 (MAX. 64.80 ) W	
MAX. CURRENT OF BACK PRESSURE	FRONT FAN: 4.0 (4.8MAX.) A	TOTAL: 9.6A (MAX.)
	REAR FAN: 4.0 (4.8MAX.) A	
SPEED	FRONT FAN: 16300+/-10% R.P.M. REAR FAN: 15500+/-10% R.P.M.	
MAX. AIR FLOW (AT ZERO STATIC PRESSURE)	3.853 (MIN. 3.467) M <sup>3</sup> /MIN. 136.036 (MIN. 122.432) CFM	
MAX. AIR PRESSURE (AT ZERO AIRFLOW)	149.82 (MIN. 121.35) mmH <sub>2</sub> O 5.899 (MIN. 4.778) inchH <sub>2</sub> O	
ACOUSTICAL NOISE (AVG.)	79.0 (MAX.83.0) dB-A	
INSULATION TYPE	UL: CLASS A	
INSULATION STRENGTH	10 MEG OHM MIN. AT 500 VDC (BETWEEN FRAME AND (+) TERMINAL)	
DIELECTRIC STRENGTH	5 mA MAX. AT 500 VAC 50/60 Hz ONE MINUTE, (BETWEEN FRAME AND (+) TERMINAL)	

(continued)

PART NO:

DELTA MODEL: GFB0812ES-E

LIFE EXPECTANCE(IL10) (AT LABEL VOLTAGE)	70,000 HOURS CONTINUOUS OPERATION AT 40 ° C WITH 15 ~ 65 %RH.
ROTATION	TWO FANS ROTATE IN COUNTER DIRECTIONS SHOWN IN THE NAME PLATE SIDE
LOCK ROTOR SHUT DOWN	THE CURRENT WILL SHUT DOWN, WHEN ROTOR LOCKED AND FIXED.

NOTES:

1. ALL READINGS ARE MEASURED AFTER STABLY WARMING UP THROUGH 10 MINUTES.
2. STANDARD AIR PROPERTY IS AIR AT (Td) 25°C TEMPERATURE, (RH) 65% RELATIVE HUMIDITY , AND (Pb) 760 mmHg BAROMETRIC PRESSURE.
3. THE VALUES WRITTEN IN PARENS , ( ), ARE LIMITED SPEC.
4. THE CHARACTERS SHOWED IN PAGE 1 IS THE CONDITION OF BOTH FANS RUN.
5. ACOUSTICAL NOISE MEASURING CONDITION:

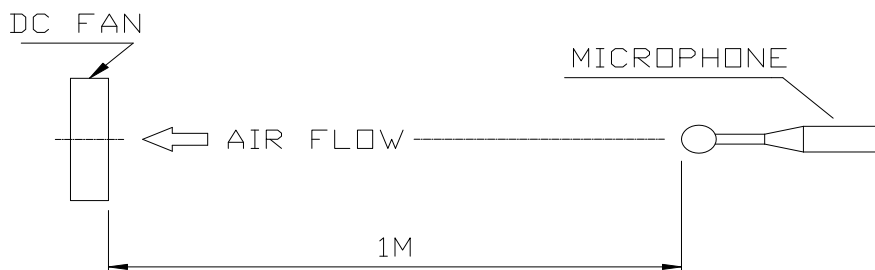

NOISE IS MEASURED AT RATED VOLTAGE IN FREE AIR IN SEMI-ANECHOIC CHAMBER WITH MICROPHONE AT A DISTANCE OF ONE METER FROM THE FAN INTAKE.

---

PART NO:

---

DELTA MODEL: GFB0812ES-E

---

3. MECHANICAL:

- 3-1. DIMENSIONS----- SEE DIMENSIONS DRAWING
- 3-2. FRAME----- PLASTIC UL: 94V-0
- 3-3. IMPELLER----- PLASTIC UL: 94V-0
- 3-4. BEARING SYSTEM----- TWO BALL BEARINGS
- 3-5. WEIGHT----- 330 GRAMS (REF.)

4. ENVIRONMENTAL:

- 4-1. OPERATING TEMPERATURE----- -10 TO +70 DEGREE C
- 4-2. STORAGE TEMPERATURE----- -40 TO +75 DEGREE C
- 4-3. OPERATING HUMIDITY----- 5 TO 90 % RH
- 4-4. STORAGE HUMIDITY----- 5 TO 95 % RH

5. PROTECTION:

- 5-1. LOCKED ROTOR PROTECTION  
IMPEDANCE OF MOTOR WINDING PROTECTS MOTOR FROM FIRE IN  
96 HOURS OF LOCKED ROTOR CONDITION AT THE RATED VOLTAGE.
- 5-2. POLARITY PROTECTION  
BE CAPABLE OF WITHSTANDING IF REVERSE CONNECTION FOR  
POSITIVE AND NEGATIVE LEADS.
- 5-3. INTERNAL FUSE IMPLEMENTED.

6. RE OZONE DEPLETING SUBSTANCES:

- 6-1. NO CONTAINING PBBs, PBBOs, CFCs, PBBEs, PBDPEs AND HCFCs.

7. PRODUCTION LOCATION

- 7-1. PRODUCTS WILL BE PRODUCED IN CHINA OR THAILAND.

8. TURBO FUNCTION

- 8-1. THERE WILL BE A TURBO FUNCTION (REAR ROTOR ACCELERATE)  
WHEN THE FRONT ROTOR OF FAN IS FAILED.  
(IT IS RECOMMENDED TO REPLACE THE FAN AFTER THE TURBO  
FUNCTION START UP.)
- 8-2. WHEN THE FRONT ROTOR OF FAN IS FAILED, THE REAR FAN WILL  
RUN AT 17300 +/- 20% RPM IN FREE AIR CONDITION.  
(@FRONT ROTOR FREE RUN)  
(IT IS NOT RECOMMENDED TO USE ONLY THE REAR FAN AS THE  
FREQUENCY GENERATOR (FG) SIGNAL OF THE WHOLE FAN.)

PART NO:

DELTA MODEL: GFB0812ES-E

8. P & Q CURVE:

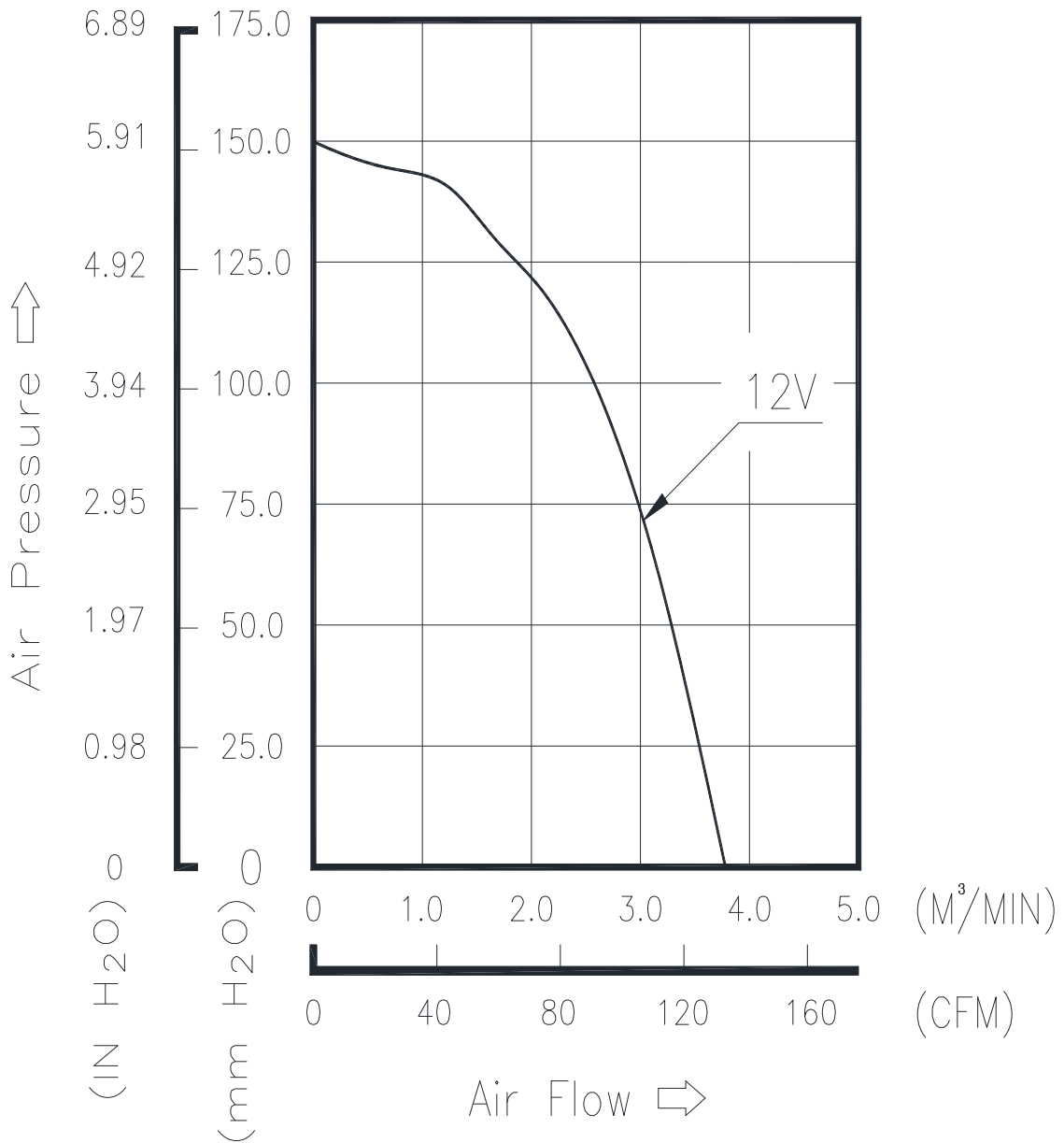

\*TEST CONDITION: INPUT VOLTAGE-----OPERATION VOLTAGE  
TEMPERATURE-----ROOM TEMPERATURE  
HUMIDITY-----65%RH

PART NO:

DELTA MODEL: GFB0812ES-E

9. DIMENSION DRAWING:

LABEL:

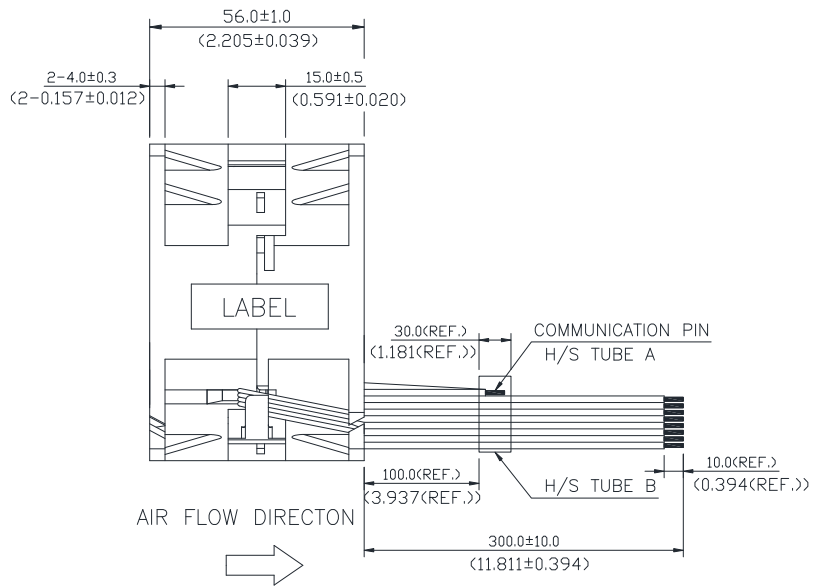
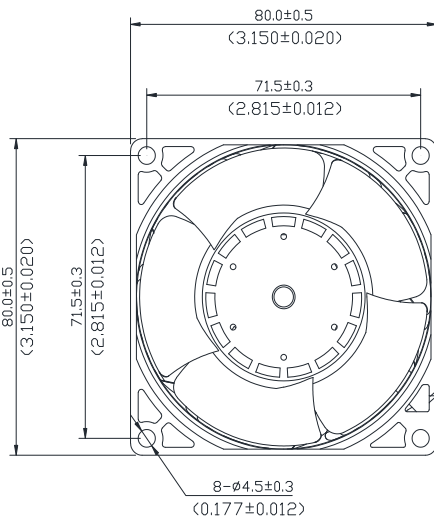
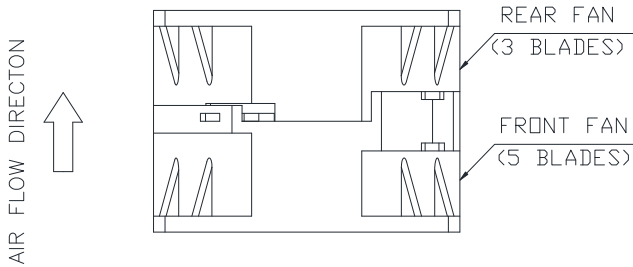
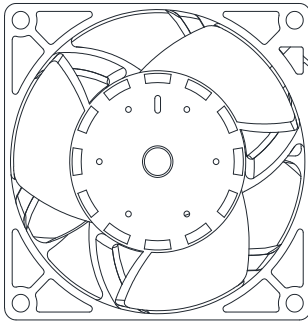
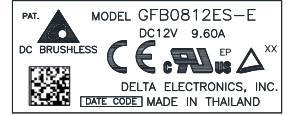
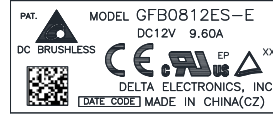
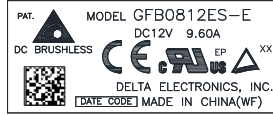
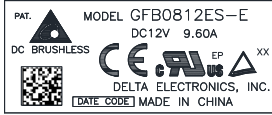

UNIT: mm (INCH)

---

PART NO:

---

DELTA MODEL: GFB0812ES-E

---

NOTES:

1. CABLE WIRE:

- RED WIRE-----(+ ) FRONT FAN (UL 1061 AWG#22)
- ORANGE WIRE-----(+ ) REAR FAN (UL 1061 AWG#22)
- BLUE WIRE----- (PWM) FRONT FAN (UL 1061 AWG#26)
- GREEN WIRE----- (PWM) REAR FAN (UL 1061 AWG#26)
- BLACK WIRE----- (-) FRONT FAN (UL 1061 AWG#22)
- GRAY WIRE----- (-) REAR FAN (UL 1061 AWG#22)
- YELLOW WIRE----- (F00) FRONT FAN (UL 1061 AWG#26)
- WHITE WIRE----- (F00) REAR FAN (UL 1061 AWG#26)
- PURPLE WIRE----- (COMMUNICATE) FRONT FAN(UL 1061 AWG#26)
- BROWN WIRE----- (COMMUNICATE) REAR FAN(UL1061 AWG#26)

2. H/S TUBE A: 2.0\* $\varnothing$ 0.25 , 120°C , 600V, BLACK

3. H/S TUBE B: 5.0\* $\varnothing$ 0.25 , 120°C , 600V, BLACK

4. THIS PRODUCT IS RoHS COMPLIANT



PART NO:

DELTA MODEL: GFB0812ES-E

10. FREQUENCY GENERATOR (FG) SIGNAL:

10-1. OUTPUT CIRCUIT - OPEN COLLECTOR MODE:

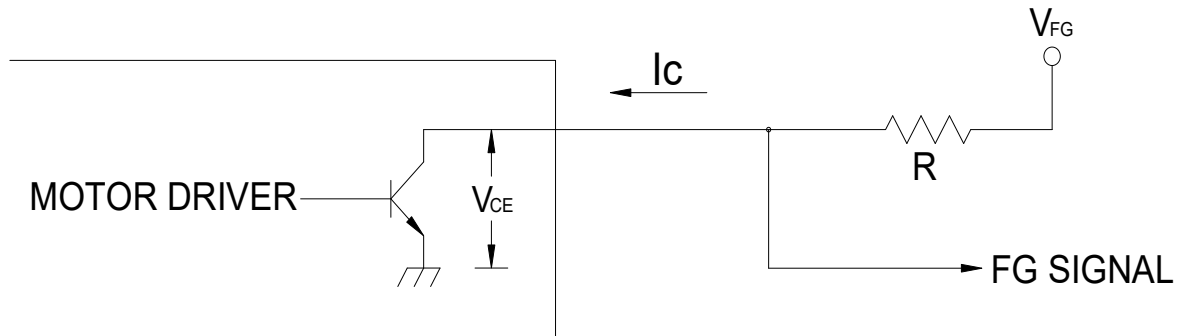

CAUTION:

THE LEAD WIRE OF FG SIGNAL CAN NOT TOUCH  
THE LEAD WIRE OF POSITIVE OR NEGATIVE.

10-2. SPECIFICATION:

$V_{CE(sat)} = 0.5V \text{ MAX.}$

$V_{FG} = 13.2VDC \text{ MAX.}$

$I_c = 5mA \text{ MAX.}$

$R \geq V_{FG} / I_c$

10-3. FREQUENCY GENERATOR WAVEFORM:

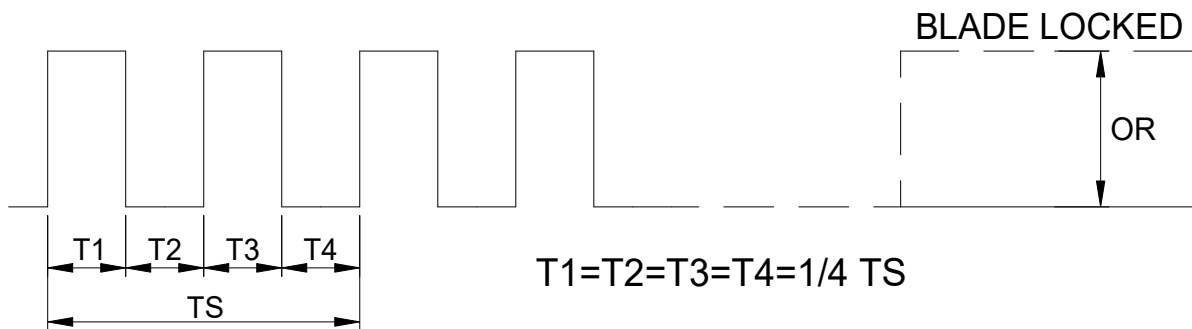
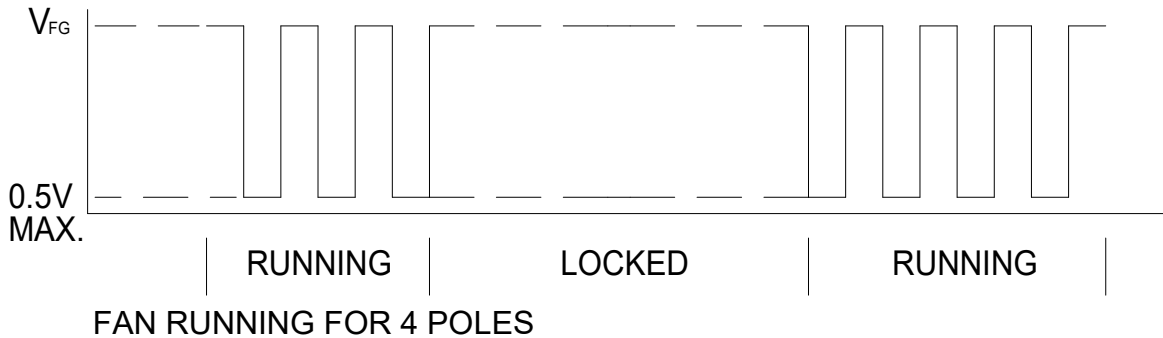

$N = \text{R.P.M}$

$TS = 60/N(\text{SEC})$

\*VOLTAGE LEVEL AFTER BLADE LOCKED

\*4 POLES

PART NO:

DELTA MODEL: GFB0812ES-E

11. PWM CONTROL SIGNAL:

SIGNAL VOLTAGE RANGE: 0~16.0 VDC

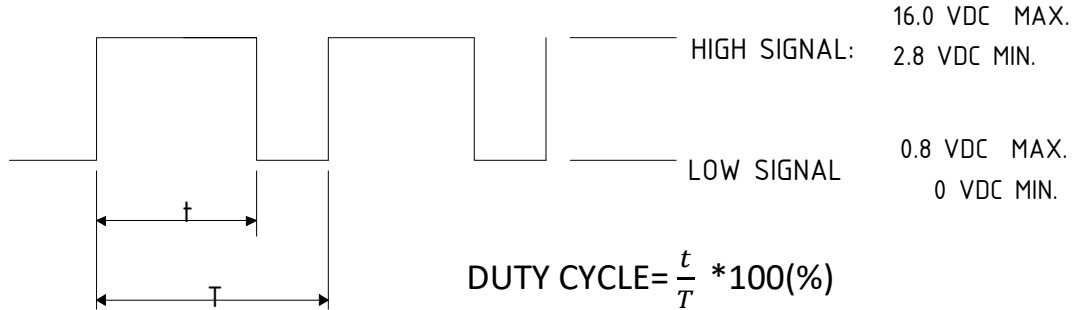

\*THE FAN FREQUENCY CONTROL SIGNAL SHALL BE ABLE TO ACCEPT 16K~32KHz.

\*THE PREFERRED OPERATING POINT FOR THE FAN IS 25K HZ.

\*AT 100% DUTY CYCLE, THE ROTOR WILL SPIN AT MAXIMUM SPEED.

\*AT 0% DUTY CYCLE, THE ROTOR WILL SPIN AT MINIMUM SPEED.

\*WITH CONTROL SIGNAL LEAD DISCONNECTED, THE FAN WILL SPIN AT MAXIMUM SPEED.

\*THE FAN SPEED CONTROL IS CLOSED-LOOP .

12. SPEED VS PWM CONTROL SIGNAL:

(RAW FAN AT 25°C, RATED VOLTAGE & PWM SIGNAL AS FOLLOW)

DUTY CYCLE (%)	SPEED R.P.M. (REF.)		TYP. TOTAL CURRENT (A)	MAX. TOTAL CURRENT (A)
	FRONT	REAR		
100	16300±10%	15500±10%	4.50A	5.40A
50	8670±10%	8250±10%	0.85A	1.02A
0	1630±300	1550±300	0.09A	0.11A

13. PWM CONTROL LEAD WIRE INPUT IMPEDANCE:

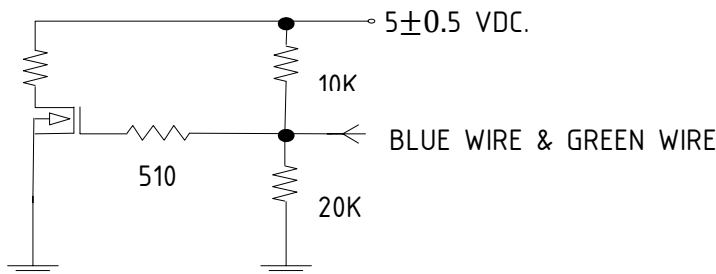



## ***Application Notice***

- 1. Delta will not guarantee the performance of the products if the application condition falls outside the parameters set forth in the specification.**
- 2. A written request should be submitted to Delta prior to approval if deviation from this specification is required.**
- 3. Please exercise caution when handling fans. Damage may be caused when pressure is applied to the impeller, if the fans are handled by the lead wires, or if the fan was hard-dropped to the production floor.**
- 4. Except as pertains to some special designs, there is no guarantee that the products will be free from any such safety problems or failures as caused by the introduction of powder, droplets of water or encroachment of insect into the hub.**
- 5. The above-mentioned conditions are representative of some unique examples and viewed as the first point of reference prior to all other information.**
- 6. It is very important to establish the correct polarity before connecting the fan to the power source. Positive (+) and Negative (-). Damage may be caused to the fans if connection is with reverse polarity, if there is no foolproof method to protect against such error specifically mentioned in this spec.**
- 7. Delta fans without special protection are not suitable where any corrosive fluids are introduced to their environment.**
- 8. Please ensure all fans are stored according to the storage temperature limits specified. Do not store fans in a high humidity environment. We highly recommend performance testing is conducted before shipping, if the fans have been stored over 6 months.**
- 9. Not all fans are provided with the Lock Rotor Protection feature. If you impair the rotation of the impeller for the fans that do not have this function, the performance of those fans will lead to failure.**
- 10. Please be cautious when mounting the fan. Incorrect mounting of fans may cause excess resonance, vibration and subsequent noise.**
- 11. It is important to consider safety when testing the fans. A suitable fan guard should be fitted to the fan to guard against any potential for personal injury.**
- 12. Except where specifically stated, all tests are carried out at room (ambient) temperature and relative humidity conditions of 25°C, 65% RH. The test value is only for fan performance itself.**
- 13. Be certain to connect an “ 4.7μF or greater” capacitor to the fan externally when the application calls for using multiple fans in parallel, to avoid any unstable power.**