

# **TPA3132D2EVM Audio Amplifier Evaluation Module**

---



---



---

This evaluation module allows users to evaluate the TI's TPA3132D2 audio amplifier. This user's guide contains an operations description, schematic, printed-circuit board (PCB) layout, and the bill of materials.

### **Contents**

1	Introduction .....	2
2	Operation .....	3
2.1	Quick-Start List for Stand-Alone Operation .....	3
3	Schematic, Layout, and Bill of Materials .....	4
3.1	TPA3132D2EVM Schematic .....	4
3.2	TPA3132D2EVM Printed-Circuit Board Layers .....	5
3.3	TPA3132D2EVM Bill of Materials .....	6

### **List of Figures**

1	TPA3132D2EVM Audio Power Amplifier – Top View .....	2
2	TPA3132D2EVM Audio Power Amplifier – Bottom View .....	2
3	TPA3132D2EVM Schematic.....	4
4	TPA3132D2EVM – Top-Side Layout .....	5
5	TPA3132D2EVM – Bottom-Side Layout .....	5

### **List of Tables**

1	Power Supply Requirements .....	3
2	TPA3132D2EVM Jumpers .....	3
3	TPA3132D2EVM Bill of Materials.....	6

## 1 Introduction

The TPA3132D2EVM (EVM) customer evaluation module, [Figure 1](#) and [Figure 2](#), demonstrates the TPA3132D2 integrated circuit (IC) from TI.

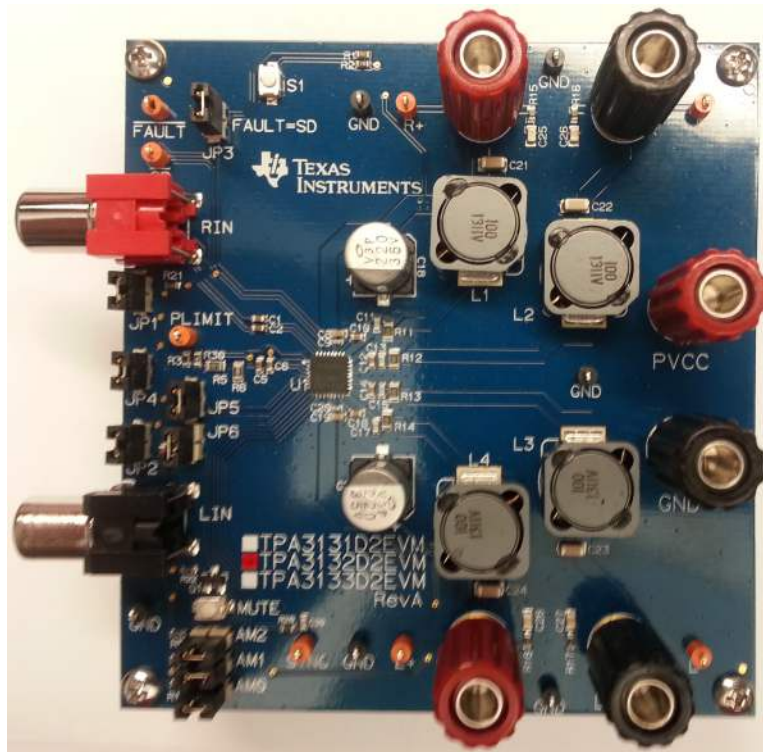

**Figure 1. TPA3132D2EVM Audio Power Amplifier – Top View**

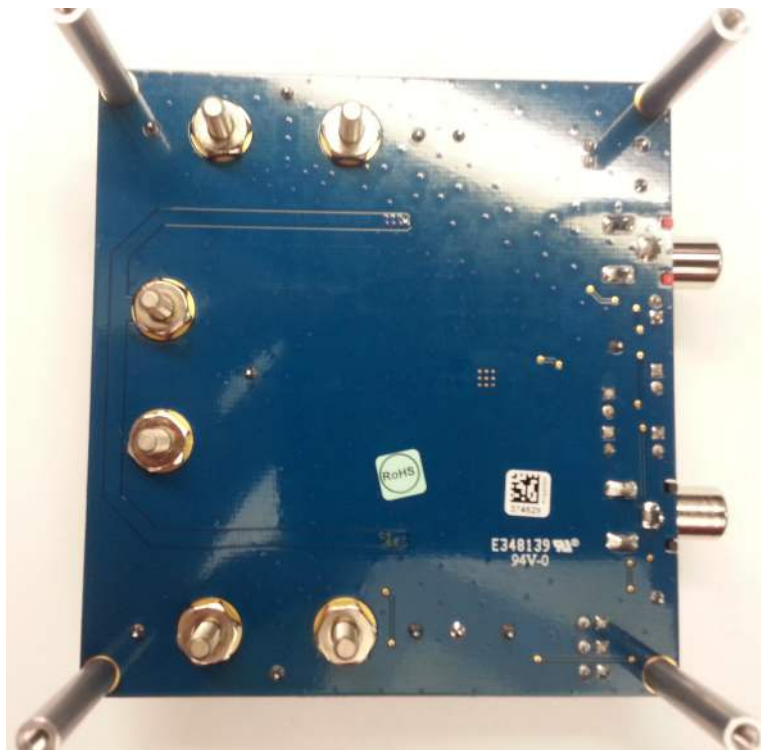

**Figure 2. TPA3132D2EVM Audio Power Amplifier – Bottom View**

## 2 Operation

### 2.1 Quick-Start List for Stand-Alone Operation

Section 2.1.1 and Section 2.1.2 provide instructions for the TPA3132D2EVM in stand-alone operation or when connecting it into existing circuits or equipment. Connections to the EVM power supply and output connectors can be made by inserting stripped wire or using banana jacks. The input connectors are RCA phono jacks.

#### 2.1.1 Power Supply

A single power supply is required to power the EVM. Because most of the pins are PVCC compliant, the PVCC supply can also be used to power the analog supply (AVcc) and to pull up the logic pins for shutdown (SD) control, and gain (GAIN). PLIMIT can be powered by an external supply connected to the PLIMIT pin. Do not power the PLIMIT pin through the PLIMIT network when the PVCC supply is turned off. This can damage the IC.

**Table 1. Power Supply Requirements**

Description	Voltage Range	Current Requirements	Wire Size
PVCC	4.5 V to 26 V	3 A	24 AWG

1. Ensure that the external regulated power supply is turned OFF.
2. Connect the external regulated power supply, adjusted from 4.5 V to 26 V, to the PVCC and GND banana jacks on the EVM taking care to observe marked polarity.

#### 2.1.2 EVM Preparations

##### Inputs and Outputs

1. For a BTL configuration, remove jumpers from JP5 and JP6 and connect loads across the outputs (LEFT+ and LEFT-) and (RIGHT+ and RIGHT-). For PBTL configuration, insert jumpers on JP5 and JP6 and connect a single load from one of the left speaker jacks to one of the right speaker jacks
2. Connect audio inputs, either differential or single-ended, to the LIN and RIN RCA phono plugs for BTL operation. For PBTL operation, connect a single input, differential or single-ended, to the RIN RCA phono plug.

**Table 2. TPA3132D2EVM Jumpers**

Jumper	Function	Options	Notes
JP1	RCA Gnd to board GND		
JP2	RCA Gnd to board GND		
JP3	Fault to SD short	Auto SD = insert, No SD= open	When inserted, fault will pull down SD
JP4	Gvdd to Plimit short	Insert to defeat, remove to enable	See datasheet ( <a href="#">SLOS841</a> )
JP5	BTL or PBTL	Insert for PBTL, remove for BTL	JP5 and JP6 should match
JP6	BTL or PBTL	Insert for PBTL, remove for BTL	JP5 and JP6 should match
AM0 AM1 AM2	Oscillator frequency	AM2=0, AM1=0, AM0=0 AM2=0, AM1=0, AM0=1 AM2=0, AM1=1, AM0=0 AM2=0, AM1=1, AM0=1 AM2=1, AM1=0, AM0=0 AM2=1, AM1=0, AM0=1 AM2=1, AM1=1, AM0=0 AM2=1, AM1=1, AM0=1	400 kHz 500 kHz 600 kHz 1000 kHz 1200 kHz Reserved Reserved Reserved

##### Power Up

1. Verify correct power supply voltage and polarity, and turn the external power supply ON. The EVM begins to operate.
2. Adjust the audio source for the correct volume.

### 3 Schematic, Layout, and Bill of Materials

#### 3.1 TPA3132D2EVM Schematic

Figure 3 illustrates the schematic for this EVM.

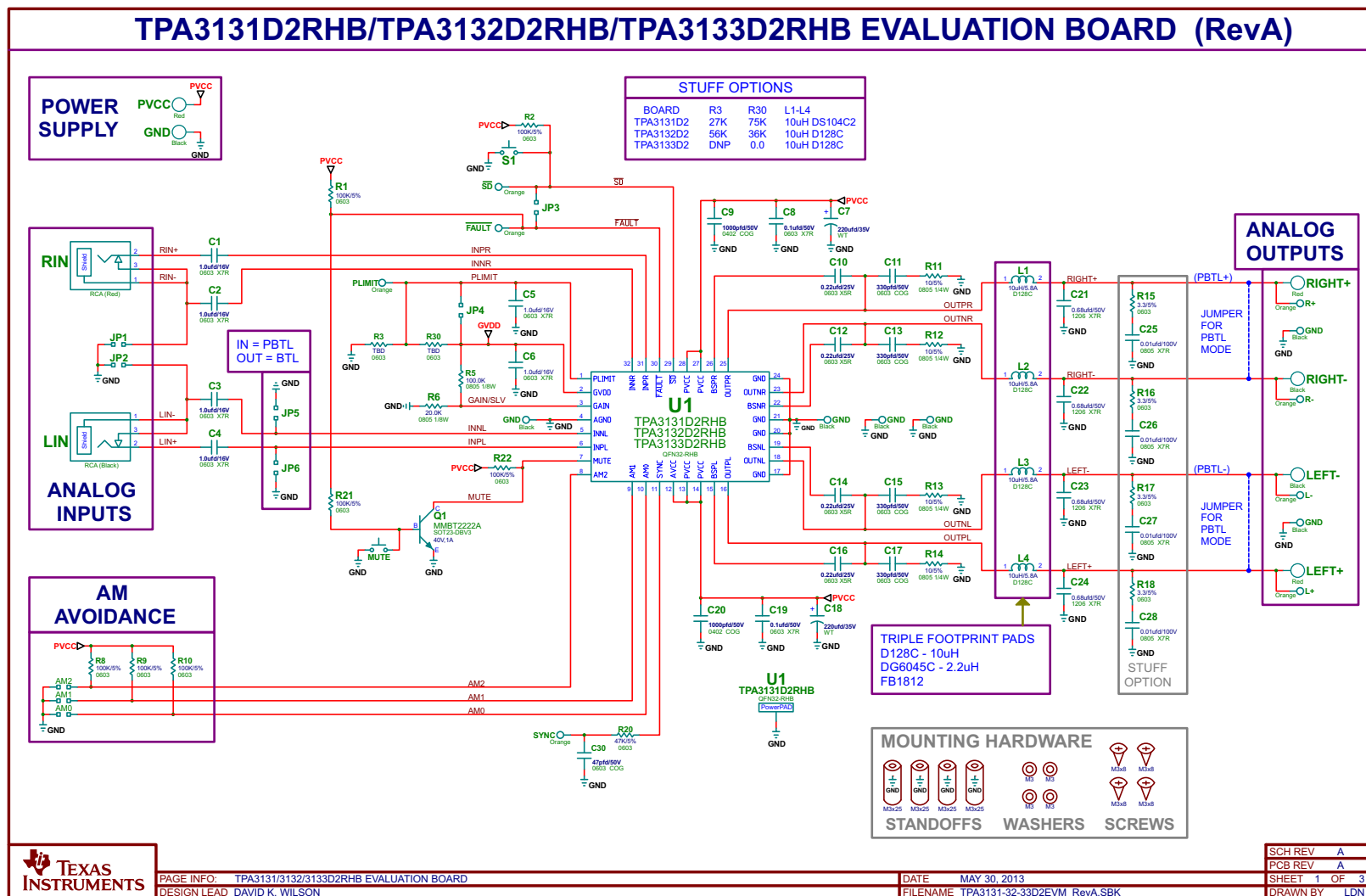

Figure 3. TPA3132D2EVM Schematic

### 3.2 TPA3132D2EVM Printed-Circuit Board Layers

Figure 4 and Figure 5 illustrate the top- and bottom-side PCB layouts for the EVM.

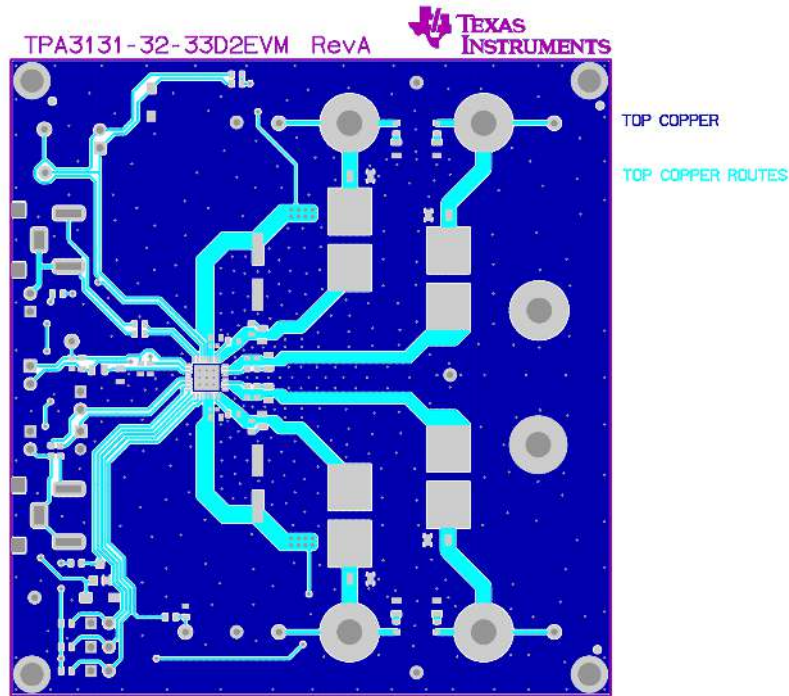

Figure 4. TPA3132D2EVM – Top-Side Layout

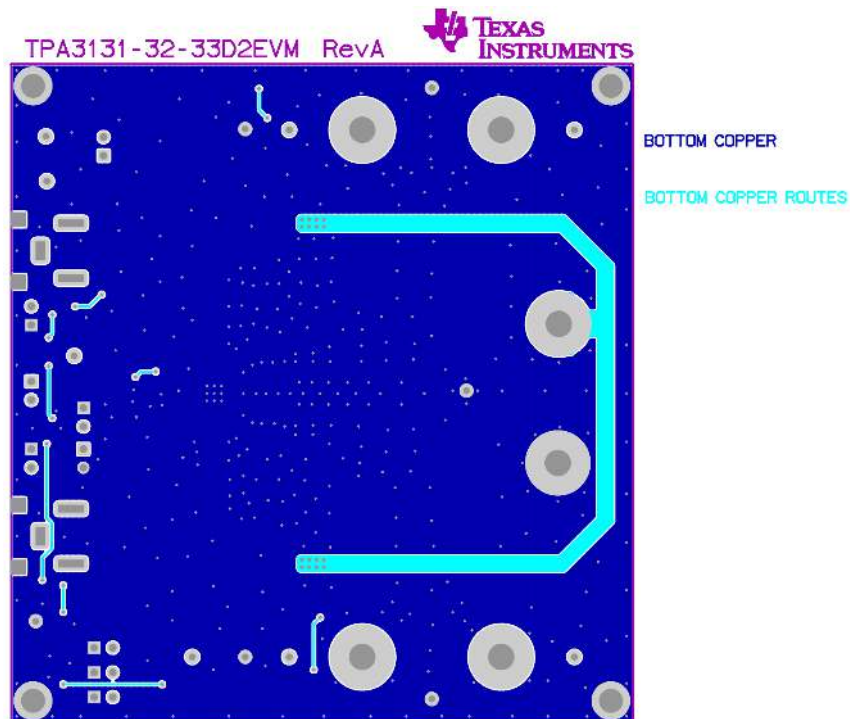

Figure 5. TPA3132D2EVM – Bottom-Side Layout



### 3.3 TPA3132D2EVM Bill of Materials

Table 3 is the TPA3132D2EVM BOM.

**Table 3. TPA3132D2EVM Bill of Materials**

Item	MANU PART NUM	MANU	Qty	REF Designators	Description
1	TPA3132D2RHB	TEXAS INSTRUMENTS	1	U1	100 W FILTER-FREE CLASS D STEREO AMP AM AVOIDANCE QFN32-RHB ROHS
2	MMBT2222A-7-F	DIODES INC.	1	Q1	TRANSISTOR NPN GENERAL PURPOSE 40V 1A SOT23 DBV3 ROHS
3	C1608X7R1C105K	TDK	6	C1, C2, C3, C4, C5, C6	CAP SMD0603 CERM 1.0UFD 16V 10% X7R ROHS
4	UWT1V221MNL1GS	NICHICON	2	C7, C18	CAP SMD ELECT 220ufd 35V 20% WT ROHS
5	GRM188R71H104KA93D	MURATA	2	C8, C19	CAP SMD0603 CERM 0.1UFD 50V 10% X7R ROHS
6	GRM1555C1H102JA01D	MURATA	2	C9, C20	CAP SMD0402 CERM 1000pfd 5% 50V COG ROHS
7	06033D224KAT2A	AVX	4	C10, C12, C14, C16	CAP SMD0603 CERM 0.22UFD 25V 10% X5R ROHS
8	GRM1885C1H331JA01D	MURATA	4	C11, C13, C15, C17	CAP SMD0603 CERM 330PFD 50V 5% COG ROHS
9	C1206C684K5RACTU	KEMET	4	C21, C22, C23, C24	CAP SMD1206 CERM 0.68UFD 50V 10% X7R ROHS
10	GRM21BR72A103KA01L	MURATA	4	C25, C26, C27, C28	CAP SMD0805 CERM 0.01UFD 100V 10% X7R ROHS
11	GRM1885C1H470JA01D	MURATA	1	C30	CAP SMD0603 CERM 47PFD 50V 5% COG ROHS
12	RMCF0603JT100K	STACKPOLE ELECTRONICS	7	R1, R2, R8, R9, R10, R21, R22	RESISTOR SMD0603 100K OHMS 5% 1/10W ROHS
13	ERJ-3EKF5602V	PANASONIC	1	R3	RESISTOR SMD0603 56.0K OHM 1% THICK FILM 1/10W ROHS
14	MCR10EZHF1003	ROHM	1	R5	RESISTOR SMD0805 100.0 KOHMS 1% 1/8W ROHS
15	MCR10EZHF2002	ROHM	1	R6	RESISTOR SMD0805 20.0 KOHMS 1% 1/8W ROHS
16	ESR10EZPJ100	ROHM	4	R11, R12, R13, R14	RESISTOR SMD0805 10 OHM 5% 1/4W ROHS
17	ERJ-3GEYJ3R3V	PANASONIC	4	R15, R16, R17, R18	RESISTOR SMD0603 3.3 OHMS 5% 1/10W ROHS
18	ERJ-3GEYJ473V	PANASONIC	1	R20	RESISTOR SMD0603 47K OHMS 5% 1/10W ROHS
19	RC0603FR-0736KL	YAGEO	1	R30	RESISTOR SMD0603 THICK FILM 36.0K OHMS 1% 1/10W ROHS
20	931BS-100M	TOKO	4	L1, L2, L3, L4	INDUCTOR 10uH 5.8A TYPE D128C ROHS
21	PBC02SAAN	SULLINS	9	AM0, AM1, AM2, JP1, JP2, JP3, JP4, JP5, JP6	HEADER THRU MALE 2 PIN 100LS GOLD ROHS
22	PJRN1X1U013	SWITCHCRAFT	1	RIN	JACK, RCA 3-PIN PCB-RA RED ROHS
23	PJRN1X1U01X	SWITCHCRAFT	1	LIN	JACK, RCA 3-PIN PCB-RA BLACK ROHS
24	5001	KEYSTONE ELECTRONICS	6	G1, G2, G3, G4, G5, G6	PC TESTPOINT, BLACK, ROHS
25	5003	KEYSTONE ELECTRONICS	8	L+, L-, R+, R-, SD, SYNC, FAULT, PLIMIT	PC TESTPOINT, ORANGE, ROHS
26	TL1015AF160QG	E-SWITCH	2	S1, MUTE	SWITCH, MOM, 160G SMT 4X3MM ROHS
27	7006	KEYSTONE ELECTRONICS	3	PVCC, LEFT+, RIGHT+	BINDING POST, RED, 15A ECONO ROHS
28	7007	KEYSTONE ELECTRONICS	3	GND, LEFT-, RIGHT-	BINDING POST, BLACK, 15A ECONO ROHS

**Table 3. TPA3132D2EVM Bill of Materials (continued)**

Item	MANU PART NUM	MANU	Qty	REF Designators	Description
29	95947A018	MCMaster-CARR	4	STANDOFFS	STANDOFF M3x25mm 4.5mm DIA HEX ALUM F-F ROHS
30	92148A150	MCMaster-CARR	4	STANDOFF WASHERS	WASHER SPLIT-LOCK M3 6.2mm OD 0.7mm THICK STAINLESS STEEL ROHS
31	92000A118	MCMaster-CARR	4	STANDOFF SCREWS	SCREW M3x8 PHILIPS PANHEAD STAINLESS STEEL ROHS
32	969102-0000-DA	3M	9	AM0, AM1, AM2, JP1, JP2, JP3, JP4, JP5, JP6	SHUNT BLACK AU FLASH 0.100LS OPEN TOP ROHS
<b>TOTAL</b>			<b>109</b>		
<b>SPECIAL NOTES TO THIS BILL OF MATERIALS</b>					
SN1	These assemblies are ESD sensitive, ESD precautions shall be observed.				
SN2	These assemblies must be clean and free from flux and all contaminants. Use of no clean flux is not acceptable.				
SN3	These assemblies must comply with workmanship standards IPC-A-610 Class 2.				
SN4	Ref designators marked with an asterisk (***) cannot be substituted. All other components can be substituted with equivalent MFG's components.				

## IMPORTANT NOTICE

Texas Instruments Incorporated and its subsidiaries (TI) reserve the right to make corrections, enhancements, improvements and other changes to its semiconductor products and services per JESD46, latest issue, and to discontinue any product or service per JESD48, latest issue. Buyers should obtain the latest relevant information before placing orders and should verify that such information is current and complete. All semiconductor products (also referred to herein as "components") are sold subject to TI's terms and conditions of sale supplied at the time of order acknowledgment.

TI warrants performance of its components to the specifications applicable at the time of sale, in accordance with the warranty in TI's terms and conditions of sale of semiconductor products. Testing and other quality control techniques are used to the extent TI deems necessary to support this warranty. Except where mandated by applicable law, testing of all parameters of each component is not necessarily performed.

TI assumes no liability for applications assistance or the design of Buyers' products. Buyers are responsible for their products and applications using TI components. To minimize the risks associated with Buyers' products and applications, Buyers should provide adequate design and operating safeguards.

TI does not warrant or represent that any license, either express or implied, is granted under any patent right, copyright, mask work right, or other intellectual property right relating to any combination, machine, or process in which TI components or services are used. Information published by TI regarding third-party products or services does not constitute a license to use such products or services or a warranty or endorsement thereof. Use of such information may require a license from a third party under the patents or other intellectual property of the third party, or a license from TI under the patents or other intellectual property of TI.

Reproduction of significant portions of TI information in TI data books or data sheets is permissible only if reproduction is without alteration and is accompanied by all associated warranties, conditions, limitations, and notices. TI is not responsible or liable for such altered documentation. Information of third parties may be subject to additional restrictions.

Resale of TI components or services with statements different from or beyond the parameters stated by TI for that component or service voids all express and any implied warranties for the associated TI component or service and is an unfair and deceptive business practice. TI is not responsible or liable for any such statements.

Buyer acknowledges and agrees that it is solely responsible for compliance with all legal, regulatory and safety-related requirements concerning its products, and any use of TI components in its applications, notwithstanding any applications-related information or support that may be provided by TI. Buyer represents and agrees that it has all the necessary expertise to create and implement safeguards which anticipate dangerous consequences of failures, monitor failures and their consequences, lessen the likelihood of failures that might cause harm and take appropriate remedial actions. Buyer will fully indemnify TI and its representatives against any damages arising out of the use of any TI components in safety-critical applications.

In some cases, TI components may be promoted specifically to facilitate safety-related applications. With such components, TI's goal is to help enable customers to design and create their own end-product solutions that meet applicable functional safety standards and requirements. Nonetheless, such components are subject to these terms.

No TI components are authorized for use in FDA Class III (or similar life-critical medical equipment) unless authorized officers of the parties have executed a special agreement specifically governing such use.

Only those TI components which TI has specifically designated as military grade or "enhanced plastic" are designed and intended for use in military/aerospace applications or environments. Buyer acknowledges and agrees that any military or aerospace use of TI components which have **not** been so designated is solely at the Buyer's risk, and that Buyer is solely responsible for compliance with all legal and regulatory requirements in connection with such use.

TI has specifically designated certain components as meeting ISO/TS16949 requirements, mainly for automotive use. In any case of use of non-designated products, TI will not be responsible for any failure to meet ISO/TS16949.

### Products

Audio	<a href="http://www.ti.com/audio">www.ti.com/audio</a>
Amplifiers	<a href="http://amplifier.ti.com">amplifier.ti.com</a>
Data Converters	<a href="http://dataconverter.ti.com">dataconverter.ti.com</a>
DLP® Products	<a href="http://www.dlp.com">www.dlp.com</a>
DSP	<a href="http://dsp.ti.com">dsp.ti.com</a>
Clocks and Timers	<a href="http://www.ti.com/clocks">www.ti.com/clocks</a>
Interface	<a href="http://interface.ti.com">interface.ti.com</a>
Logic	<a href="http://logic.ti.com">logic.ti.com</a>
Power Mgmt	<a href="http://power.ti.com">power.ti.com</a>
Microcontrollers	<a href="http://microcontroller.ti.com">microcontroller.ti.com</a>
RFID	<a href="http://www.ti-rfid.com">www.ti-rfid.com</a>
OMAP Applications Processors	<a href="http://www.ti.com/omap">www.ti.com/omap</a>
Wireless Connectivity	<a href="http://www.ti.com/wirelessconnectivity">www.ti.com/wirelessconnectivity</a>

### Applications

Automotive and Transportation	<a href="http://www.ti.com/automotive">www.ti.com/automotive</a>
Communications and Telecom	<a href="http://www.ti.com/communications">www.ti.com/communications</a>
Computers and Peripherals	<a href="http://www.ti.com/computers">www.ti.com/computers</a>
Consumer Electronics	<a href="http://www.ti.com/consumer-apps">www.ti.com/consumer-apps</a>
Energy and Lighting	<a href="http://www.ti.com/energy">www.ti.com/energy</a>
Industrial	<a href="http://www.ti.com/industrial">www.ti.com/industrial</a>
Medical	<a href="http://www.ti.com/medical">www.ti.com/medical</a>
Security	<a href="http://www.ti.com/security">www.ti.com/security</a>
Space, Avionics and Defense	<a href="http://www.ti.com/space-avionics-defense">www.ti.com/space-avionics-defense</a>
Video and Imaging	<a href="http://www.ti.com/video">www.ti.com/video</a>

### TI E2E Community

[e2e.ti.com](http://e2e.ti.com)