

THIS DRAWING IS UNPUBLISHED. RELEASED FOR PUBLICATION
 © COPYRIGHT - By - ALL RIGHTS RESERVED.

LDC		DIST		REVISIONS			
P	LTR	DESCRIPTION	DATE	DWN	APVD		
	K	REV PER ECO-12-000064	23JAN12	PY	DE		

DESCRIPTION	MATERIAL	FINISH
SHRINK TUBING	MIL-I-23053	
RETAINING CLIP	BeCu ASTM-B-194 OR STAINLESS STEEL PER QQ-S-766	
SOCKET CONTACT	BERYLIUM COPPER PER ASTM B196	GOLD PLATE MIL-G-45204
HOUSING	GLASS REINFORCED VALOX & EPOXY	
GROMMET	FLUROROSILICONE	

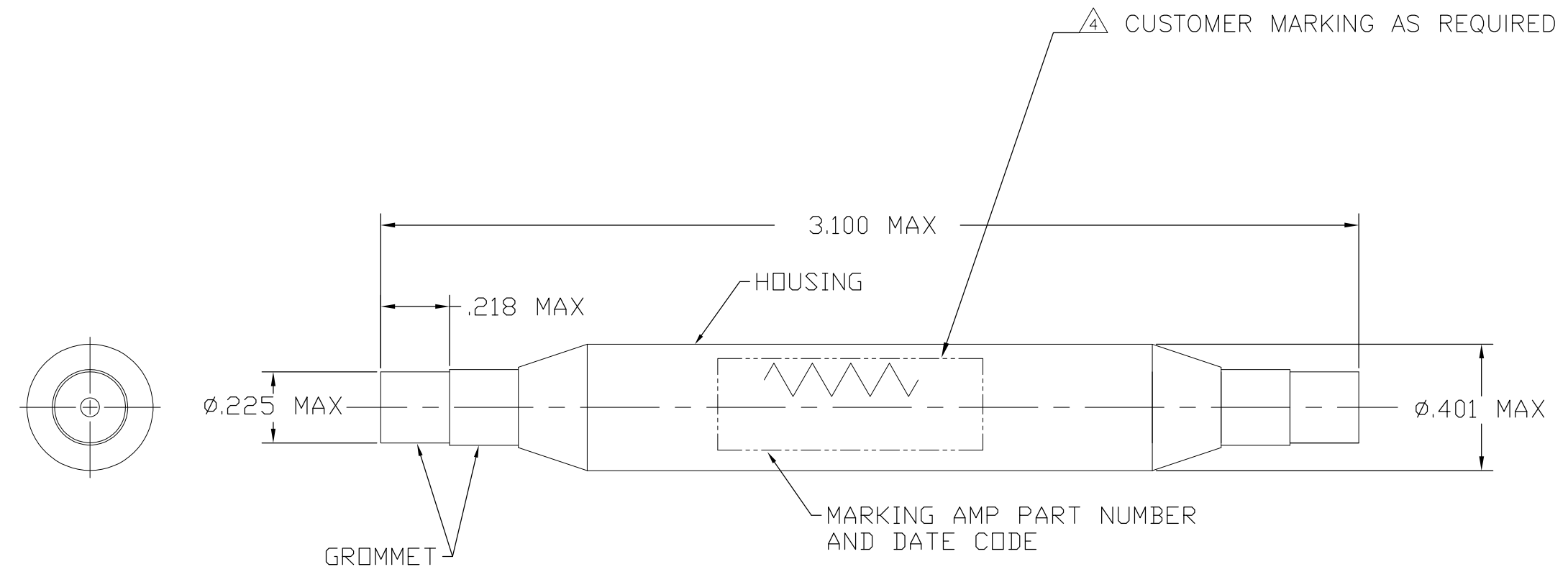

- ⚠ ENVIRONMENTS CREATED DURING OPERATION WHICH EXCEEDS THE WIRE SPLICE RATED PERFORMANCE IS THE RESPONSIBILITY OF THE USER. THE RESISTOR SPECIFICATIONS SHOULD BE CONSULTED.
- ⚠ PIN CONTACT, SEALING PLUGS & INSERTION/EXTRACTION TOOL TO BE ORDERED SEPARATELY.
- A) PIN CONTACT: 2-592404-1
- B) SEALING PLUG: 592104-1
- C) TOOL: 592105-1
- ⚠ THIS ASSEMBLY MEETS OR EXCEEDS THE GENERAL REQUIREMENTS OF MIL-T-81714.

			RLR20C2202GR	±2°	1/2	22K	1-591917-4
			RLR32C1000GR	±2°	1	100	1-591917-3
			RLR07C1001GR	±2°	1/4	1K	1-591917-2
		OBSOLETE	-	±1°	1/2	100K	1-591917-1
		OBSOLETE	-	±1°	1/2	10K	1-591917-0
		OBSOLETE	-	±1°	1/4	2.2K	591917-9
		OBSOLETE	-	±1°	1/4	127	591917-8
		OBSOLETE	RLR32C1000GS	±2°	1	100	591917-7
		OBSOLETE	-	±1°	1/2	100	591917-6
			RLR32C1201GM	±2°	1	1.2K	591917-5
			RC20GF681J	±5°	1/2	680	591917-4
			RNC60J1002FS	±1°	1/8	10K	591917-3
		12810-1	RN65C1270F	±1°	1/2	127	591917-2
			RN65C1270F	±1°	1/2	127	591917-1

THIS DRAWING IS A CONTROLLED DOCUMENT.		DWN T. THOMPSON 08NOV2001	TE TE Connectivity	
DIMENSIONS: INCHES		CHK C. CHEHOVIN 03-10-96		
TOLERANCES UNLESS OTHERWISE SPECIFIED:		APVD C. CHEHOVIN 03-10-96	NAME WIRE SPLICE, SINGLE SIZE 20	
0 PLC ± -		PRODUCT SPEC -	SIZE CAGE CODE DRAWING NO RESTRICTED TO	
1 PLC ± -		APPLICATION SPEC -	A2 00779 C-591917	
2 PLC ± .01		WEIGHT -	SCALE 1:1 SHEET 1 OF 1 REV K	
3 PLC ± .005		CUSTOMER DRAWING		
4 PLC ± -				
ANGLES ± -				
FINISH -				