

HDTV CLOCK SYNTHESIZER

MK2716

Description

The MK2716 is a low-cost, low jitter, high-performance PLL clock synthesizer designed to produce the 74.176 MHz and 74.25 MHz clocks necessary for HDTV systems. Using IDT's patented analog Phase-Locked Loop (PLL) techniques, the device accepts a 27 MHz crystal or clock input. The zero ppm synthesis error exactly locks the display to the digital stream.

IDT manufactures the largest variety multimedia clock synthesizers for all applications. Consult IDT to eliminate crystals and oscillators from your board.

For applications that require lower jitter, such as SDI and pixel clocks, use the ICS664.

Features

- Packaged in 8-pin SOIC
- Available in Pb (lead) free package
- Input frequency of 27 MHz
- Zero ppm synthesis error in output clock
- 3.3 V or 5 V $\pm 10\%$ operating supply
- Ideal for HDTV applications and oscillator manufacturers
- 25 mA output drive capability at TTL levels
- Advanced, low power, sub-micron CMOS process
- Operating voltage of 3.3 V or 5 V

NOTE: EOL for non-green parts to occur on 5/13/10 per PDN U-09-01

Block Diagram

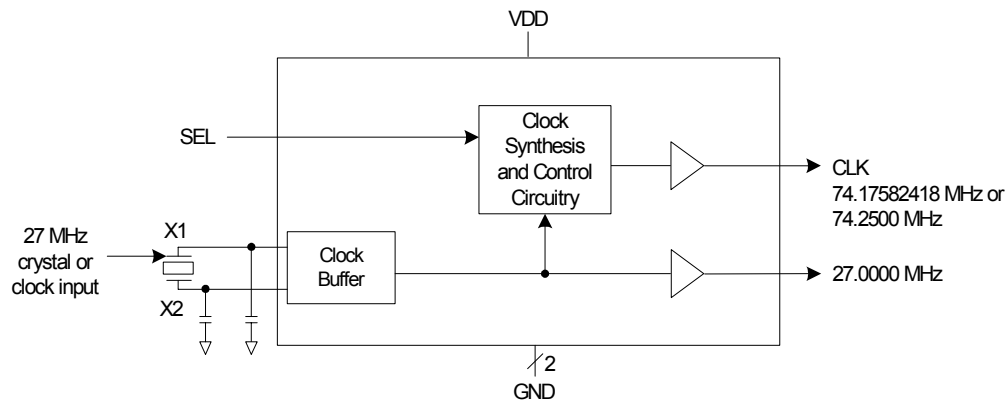

Pin Assignment

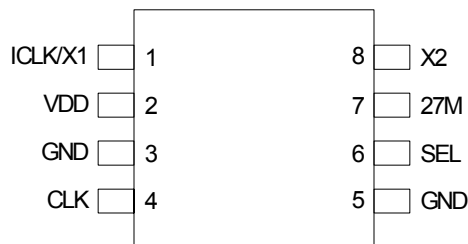

FREQUENCY SELECT TABLE

SEL	CLK (MHz)
0	74.17582418
1	74.25

Pin Descriptions

Pin Number	Pin Name	Pin Type	Pin Description
1	ICLK/X1	XI	Crystal connection. Connect to a 27 MHz fundamental crystal or clock.
2	VDD	Power	Connect to +3.3 V or +5 V.
3	GND	Power	Connect to ground.
4	27M	Output	74.17582418 MHz or 74.25 MHz clock output (see table above).
5	GND	Power	Connect to ground.
6	SEL	Input	Select pin determines value of CLK per table above.
7	27M	Output	27 MHz buffered clock or crystal oscillator output.
8	X2	XO	Crystal connection. Connect to a 27 MHz crystal, or leave unconnected for clock input.

External Components

Decoupling Capacitor

As with any high performance mixed-signal IC, the MK2716 must be isolated from system power supply noise to perform optimally.

A decoupling capacitor of 0.01 μ F must be connected between VDD and GND on pins 2 and 3. It must be connected close to the MK2716 to minimize lead inductance. Pin 5 can be connected to pin 3. No external power supply filtering is required for the MK2716.

Series Termination Resistor

A 33 Ω terminating resistor can be used next to the clock outputs for trace lengths over one inch.

Crystal Load Capacitors

The total on-chip capacitance is approximately 18 pF. A parallel resonant, fundamental mode, AT cut 27 MHz crystal

should be used. The device crystal connections should include pads for small capacitors from X1 to ground and from X2 to ground. These capacitors are used to adjust the stray capacitance of the board to match the nominally required crystal load capacitance. Because load capacitance can only be increased in this trimming process, it is important to keep stray capacitance to a minimum by using very short PCB traces (and no vias) between the crystal and device. Crystal capacitors, if needed, must be connected from each of the pins X1 and X2 to ground.

The value (in pF) of these crystal caps should equal $(C_L - 16 \text{ pF})^2$. In this equation, C_L = crystal load capacitance in pF. Example: For a crystal with an 18 pF load capacitance, each crystal capacitor would be 4 pF $[(18-16) \times 2] = 4$.

Absolute Maximum Ratings

Stresses above the ratings listed below can cause permanent damage to the MK2716. These ratings, which are standard values for IDT commercially rated parts, are stress ratings only. Functional operation of the device at these or any other conditions above those indicated in the operational sections of the specifications is not implied. Exposure to absolute maximum rating conditions for extended periods can affect product reliability. Electrical parameters are guaranteed only over the recommended operating temperature range.

Item	Rating
Supply Voltage, VDD	7 V
All Inputs and Outputs	-0.5 V to VDD+0.5 V
Ambient Operating Temperature	0 to +70° C
Storage Temperature	-65 to +150° C
Soldering Temperature	260° C

Recommended Operation Conditions

Parameter	Min.	Typ.	Max.	Units
Ambient Operating Temperature	0		+70	°C
Power Supply Voltage (measured in respect to GND)	+3.0		+5.5	V

DC Electrical Characteristics

VDD=5 V unless otherwise noted, Ambient temperature 0 to +70° C

Parameter	Symbol	Conditions	Min.	Typ.	Max.	Units
Operating Voltage	VDD		3.0	5	5.5	V
Input High Voltage	V _{IH}		2.0			V
Input Low Voltage	V _{IL}				0.8	V
Output High Voltage	V _{OH}	I _{OH} = -4 mA	VDD-0.4			V
Output Low Voltage	V _{OL}	I _{OL} = 16 mA			0.4	V
Operating Supply Current	IDD	No load		30		mA
Short Circuit Current		Each output		±50		mA
Input Capacitance	C _{IN}	S0, S1 pins		7		pF

AC Electrical Characteristics

VDD = 5 V unless otherwise noted, Ambient Temperature 0 to +70°C

Parameter	Symbol	Conditions	Min.	Typ.	Max.	Units
Input Frequency	F_{IN}			27		MHz
Frequency Error, Output Clock					0	ppm
Output Clock Rise Time	t_{OR}	0.8 to 2.0 V			1.5	ns
Output Clock Fall Time	t_{OF}	2.0 to 8.0 V			1.5	ns
Output Clock Duty Cycle		at 1.4 V	40	50	60	%
Maximum Absolute Jitter, short term	t_{ja}	Deviation from mean		200		ps

Thermal Characteristics

Parameter	Symbol	Conditions	Min.	Typ.	Max.	Units
Thermal Resistance Junction to Ambient	θ_{JA}	Still air		150		°C/W
	θ_{JA}	1 m/s air flow		140		°C/W
	θ_{JA}	3 m/s air flow		120		°C/W
Thermal Resistance Junction to Case	θ_{JC}			40		°C/W

Marking Diagram

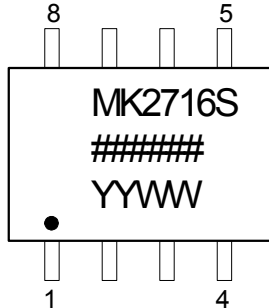

Marking Diagram (Pb free)

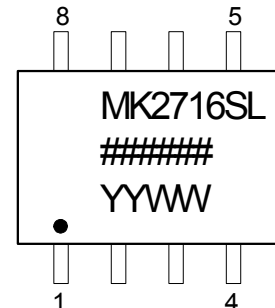

Notes:

1. ##### is the lot number.
2. YYWW is the last two digits of the year and week that the part was assembled.
3. "LF" or "L" denotes Pb (lead) free package.
4. Bottom marking: (origin)
Origin = country of origin if not USA

Package Outline and Package Dimensions (8-pin SOIC, 150 Mil. Narrow Body)

Package dimensions are kept current with JEDEC Publication No. 95

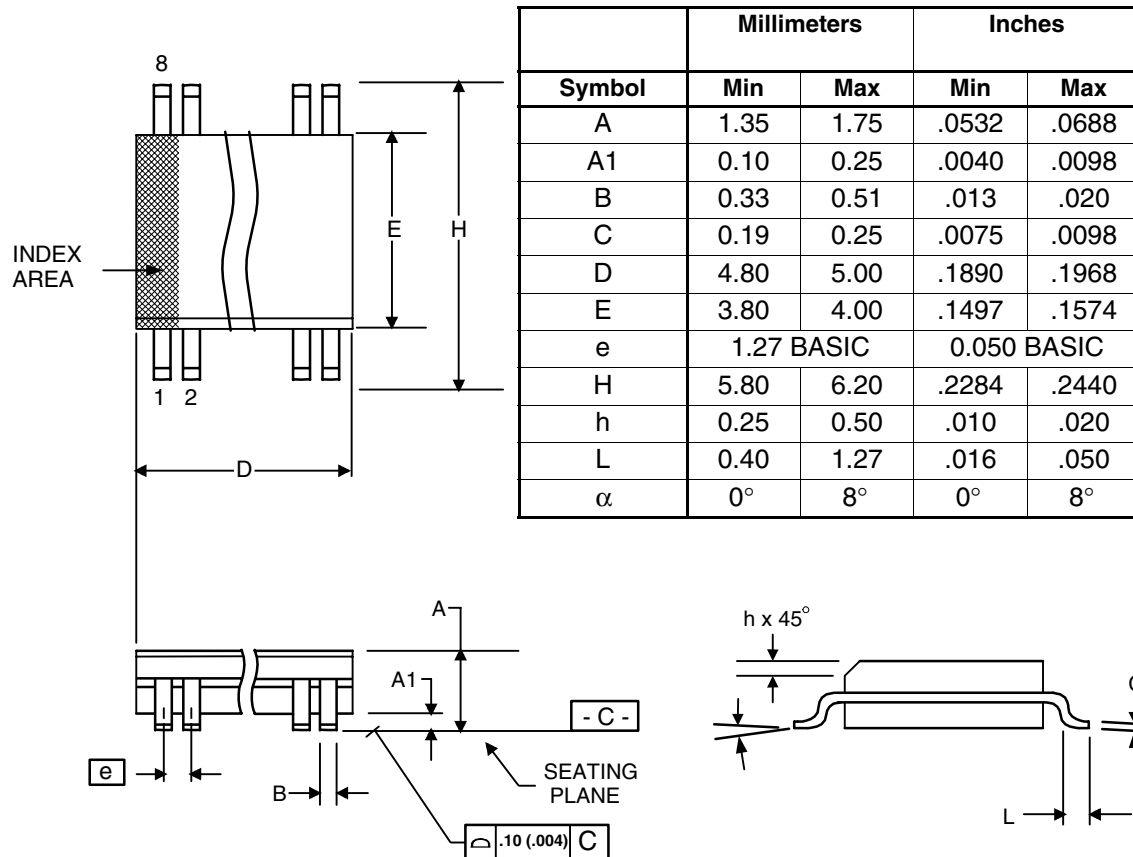

Ordering Information

Part / Order Number	Marking	Shipping Packaging	Package	Temperature
MK2716S*	MK2716S	Tubes	8-pin SOIC	0 to +70° C
MK2716STR*	MK2716S	Tape and Reel	8-pin SOIC	0 to +70° C
MK2716SLF	MK2716SL	Tubes	8-pin SOIC	0 to +70° C
MK2716SLFTR	MK2716SL	Tape and Reel	8-pin SOIC	0 to +70° C

***NOTE: EOL for non-green parts to occur on 5/13/10 per PDN U-09-01**

While the information presented herein has been checked for both accuracy and reliability, Integrated Device Technology (IDT) assumes no responsibility for either its use or for the infringement of any patents or other rights of third parties, which would result from its use. No other circuits, patents, or licenses are implied. This product is intended for use in normal commercial applications. Any other applications such as those requiring extended temperature range, high reliability, or other extraordinary environmental requirements are not recommended without additional processing by IDT. IDT reserves the right to change any circuitry or specifications without notice. IDT does not authorize or warrant any IDT product for use in life support devices or critical medical instruments.

Innovate with IDT and accelerate your future networks. Contact:

www.IDT.com

For Sales

800-345-7015
408-284-8200
Fax: 408-284-2775

For Tech Support

www.idt.com/go/clockhelp

Corporate Headquarters

Integrated Device Technology, Inc.
www.idt.com