

12.5Gbps 4-Channel, SAS3, 10GbE ReDriver with Linear Equalization

Features

- 1-to-12.5Gbps serial link with linear equalizer
- Supports SATA Gen1/Gen2/Gen3, SAS2/3, 10GbE, and XAUI protocol
- Supports 4 differential channels
- Handles up to 34dB channel loss (42" FR4 trace, 10 meters, or SAS3 cable)
- Independent channel configuration of receiver equalization, output swing and flat gain
- Rate and coding agnostic
- Transparent to link training, OOB, Idle
- 260mW per channel power dissipation with 700 mVpp output swing
- Pin strap and I²C selectable device programming
- 4-bit selectable address bit for I²C
- Supply Voltage: 3.3V±0.3V
- Industrial Temperature Range: -40°C to 85°C
- Totally Lead-Free & Fully RoHS Compliant (Notes 1 & 2)
- Halogen and Antimony Free. "Green" Device (Note 3)
- For automotive applications requiring specific change control (i.e. parts qualified to AEC-Q100/101/200, PPAP capable, and manufactured in IATF 16949 certified facilities), please [contact us](https://www.diodes.com/quality/product-definitions/) or your local Diodes representative.
- Packaging (Pb-free & Green):
 - 42-contact TQFN (9mm x3.5mm)

Application

- Rack Server
- JBOD Storage

Description

The PI3EQX1204-C is a 4-differential-channel ReDriver™. The device reduces Inter-symbol interference by providing programmable linear equalization in output swing and flat gain. This is achieved by using the pin strapping option or I²C Control to optimize performance over a variety of physical mediums.

The PI3EQX1204-C supports four 100Ω differential CML data I/O's and extends the signals across other distant data pathways on the user's platform.

The integrated equalization circuitry provides signal integrity flexibility before the ReDriver, whereas the integrated linear amplifier/buffer circuitry provides signal integrity flexibility after the ReDriver.

Block Diagram

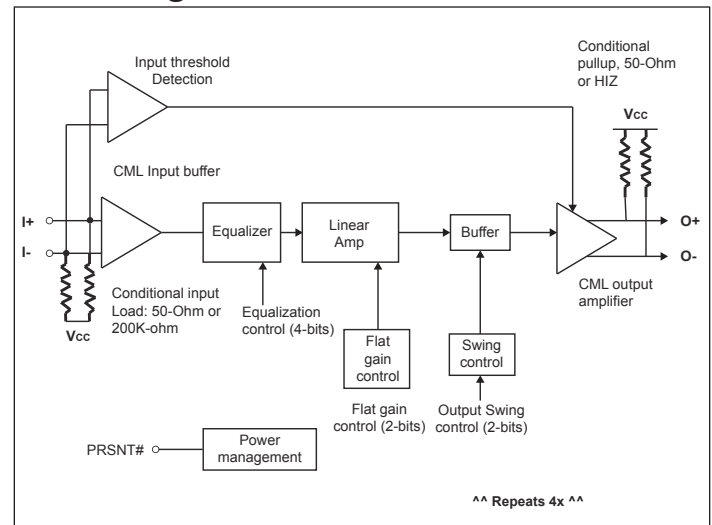

Notes:

1. No purposely added lead. Fully EU Directive 2002/95/EC (RoHS), 2011/65/EU (RoHS 2) & 2015/863/EU (RoHS 3) compliant.
2. See <https://www.diodes.com/quality/lead-free/> for more information about Diodes Incorporated's definitions of Halogen- and Antimony-free, "Green" and Lead-free.
3. Halogen- and Antimony-free "Green" products are defined as those which contain <900ppm bromine, <900ppm chlorine (<1500ppm total Br + Cl) and <1000ppm antimony compounds.

ReDriver is a trademark of Diodes Incorporated.

Pin Configuration (Top-Side View)

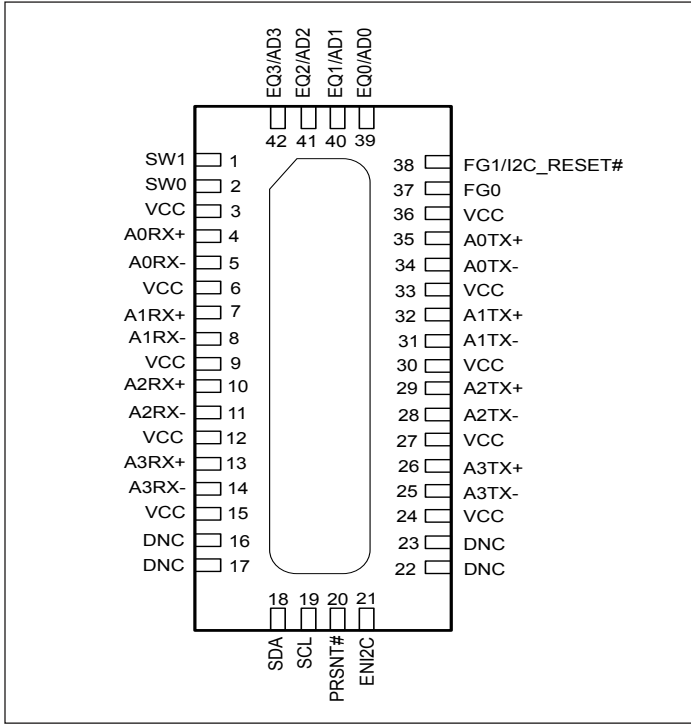

Pin Description

Pin #	Pin Name	Type	Description
Data Signals			
4	A0RX+	I	CML inputs for Channel A0, with internal 50Ω pull-up and ~200KΩ pull-up otherwise.
5	A0RX-	I	
35	A0TX+	O	CML outputs for Channel A0, with internal 50Ω pull-up and high impedance otherwise.
34	A0TX-	O	
7	A1RX+	I	CML inputs for Channel A1, with internal 50Ω pull-up and ~200KΩ otherwise.
8	A1RX-	I	
32	A1TX+	O	CML outputs for Channel A1, with internal 50Ω pull-up and high impedance otherwise.
31	A1TX-	O	
10	A2RX+	I	CML inputs for Channel A2, with internal 50Ω pull-up and ~200KΩ otherwise.
11	A2RX-	I	
29	A2TX+	O	CML outputs for Channel A2, with internal 50Ω pull-up and high impedance otherwise.
28	A2TX-	O	
13	A3RX+	I	CML inputs for Channel A3, with internal 50Ω pull-up and ~200KΩ otherwise.
14	A3RX-	I	
26	A3TX+	O	CML outputs for Channel A3, with internal 50Ω pull-up and high impedance otherwise.
25	A3TX-	O	

Pin Description Cont.

Pin #	Pin Name	Type	Description
Control Signals			
19	SCL	I	I ² C SCL clock input.
18	SDA	I	I ² C SDA data input.
42, 41, 40, 39	AD[3:0]	I	I ² C programmable address bits, with internal 100kΩ pull-up.
20	PRSNT#	I	This pin is active in both PIN mode(ENI2C=LOW) and I ² C mode (ENI2C=HIGH). Cable present detect input. This pin has internal 100KΩ pull-up. When High, a cable is not present, and the device is put in lower power mode. When LOW, the device is enabled and in normal operation.
21	ENI2C	I	When LOW, each channel is programmed by the external pin voltage. When HIGH, each channel is programmed by the data stored in the I2C bus.
42, 41, 40, 39	EQ[3:0]	I	Inputs with internal 100kΩ pull-up. This pins set the amount of Equalizer Boost in all channel when ENI2C is LOW.
1, 2	SW[1:0]	I	Inputs with internal 100kΩ pull-up. This pin sets the output Voltage Level in all channel when ENI2C is LOW.
38, 37	FG[1:0]	I	Inputs with internal 100KΩ pull up resistor. Sets the output flat gain level on all channels when ENI2C is low.
38	I ² C_RESET#	I	Inputs with internal 100KΩ pull up resistor. Reset pin for I ² C. When set low will reset the registers to default state.
16, 17, 22, 23	DNC		Do Not Connect
Power Pins			
3, 6, 9, 12, 15, 24, 27, 30, 33, 36	VCC	PWR	3.3V Supply Voltage
EP	GND	PWR	Exposed pad. Supply Ground

Description of Operation

Power Enable function:

One pin control or I²C control, when PRSNT# is set to HIGH, the IC goes into power down mode, both input and output termination set to 200K and High impedance respectively. Individual Channel Enabling is done through the I²C register programming.

Equalization Setting:

EQ[3:0] are the selection pins for the equalization selection for each channel.

Table 1. Equalization Setting

Equalizer setting							
EQ3	EQ2	EQ1	EQ0	@ 3GHz	@ 4GHz	@ 5GHz	@ 6GHz
0	0	0	0	3.6	4.5	5.5	6.8
0	0	0	1	4	5.1	6.2	7.6
0	0	1	0	4.4	5.6	6.9	8.4
0	0	1	1	4.7	6.1	7.5	9.1
0	1	0	0	5.1	6.6	8.1	9.8
0	1	0	1	5.5	7.1	8.7	10.4
0	1	1	0	5.9	7.6	9.2	11
0	1	1	1	6.2	8	9.7	11.5
1	0	0	0	6.6	8.5	10.2	12
1	0	0	1	6.9	8.9	10.7	12.5
1	0	1	0	7.3	9.3	11.1	12.9
1	0	1	1	7.6	9.7	11.5	13.3
1	1	0	0	8	10.1	11.9	13.7
1	1	0	1	8.2	10.5	12.3	14.1
1	1	1	0	8.6	10.8	12.7	14.4
1	1	1	1	8.9	11.1	13	14.7

Flat Gain Setting:

FG[1:0] are the selection bits for the DC value.

Table 2. Flat Gain Setting

Flat Gain Setting		
FG1	FG0	dB
0	0	-3.5
0	1	-1.5
1	0	0.5
1	1	2.5

Swing Setting:

Swing Setting: SW[1:0] are the selection bits for the output swing value.

Table 3. Swing Setting

SW1	SW0	mVp-p
0	0	700
0	1	800
1	0	900
1	1	1000

I²C Programming

Address assignment							
A6	A5	A4	A3	A2	A1	A0	R/W
1	1	1	AD3	AD2	AD1	AD0	1=R, 0=W

BYTE 0 Reserved							
BYTE 1 Reserved							
BYTE 2							
Bit	Type	Power up condition		Control affected	Comment		
7	R/W	0		A3 Power down	1 = Power down		
6	R/W	0		A2 Power down			
5	R/W	0		A1 Power down			
4	R/W	0		A0 Power down			
3	R/W	0					
2	R/W	0					
1	R/W	0					
0	R/W	0					
BYTE 3							
Bit	Type	Power up condition		Control affected	Comment		
7	R/W	0	Channel A0 configuration	EQ3	Equalizer		
6	R/W	0		EQ2			
5	R/W	0		EQ1			
4	R/W	0		EQ0			
3	R/W	0		FG1	Flat gain		
2	R/W	0		FG0			
1	R/W	0		SW1	Swing		
0	R/W	0		SW0			
BYTE 4							
Bit	Type	Power up condition		Control affected	Comment		
7	R/W	0	Channel A1 configuration	EQ3	Equalizer		
6	R/W	0		EQ2			
5	R/W	0		EQ1			
4	R/W	0		EQ0			
3	R/W	0		FG1	Flat gain		
2	R/W	0		FG0			
1	R/W	0		SW1	Swing		
0	R/W	0		SW0			

I²C Programming cont.

BYTE 5					
Bit	Type	Power up condition		Control affected	Comment
7	R/W	0	Channel A2 configuration	EQ3	Equalizer
6	R/W	0		EQ2	
5	R/W	0		EQ1	
4	R/W	0		EQ0	
3	R/W	0		FG1	Flat gain
2	R/W	0		FG0	
1	R/W	0		SW1	Swing
0	R/W	0		SW0	
BYTE 6					
Bit	Type	Power up condition		Control affected	Comment
7	R/W	0	Channel A3 configuration	EQ3	Equalizer
6	R/W	0		EQ2	
5	R/W	0		EQ1	
4	R/W	0		EQ0	
3	R/W	0		FG1	Flat gain
2	R/W	0		FG0	
1	R/W	0		SW1	Swing
0	R/W	0		SW0	
BYTE 7-15 with '0' power up condition Reserved					

Transferring Data

Every byte put on the SDA line must be 8-bits long. Each byte has to be followed by an acknowledge bit. Data is transferred with the most significant bit (MSB) first (see the I²C Data Transfer diagram).

Acknowledge

Data transfer with acknowledge is required from the master. When the master releases the SDA line (HIGH) during the acknowledge clock pulse, the PI3EQX1204-C will pull down the SDA line during the acknowledge clock pulse so that it remains stable LOW during the HIGH period of this clock pulse as indicated in the I²C Data Transfer diagram. The PI3EQX1204-C will generate an acknowledge after each byte has been received.

Data Transfer

A data transfer cycle begins with the master issuing a start bit. After recognizing a start bit, the PI3EQX1204-C will watch the next byte of information for a match with its address setting. When a match is found it will respond with a read or write of data on the following clocks. Each byte must be followed by an acknowledge bit, except for the last byte of a read cycle which ends with a stop bit. For a write cycle, the first data byte following the address byte is an index byte that is used by the PI3EQX1204-C. Data is transferred with the most significant bit (MSB) first.

I²C Data Transfer

Start & Stop Conditions

A HIGH to LOW transition on the SDA line while SCL is HIGH indicates a START condition. A LOW to HIGH transition on the SDA line while SCL is HIGH defines a STOP condition, as shown in the figure below

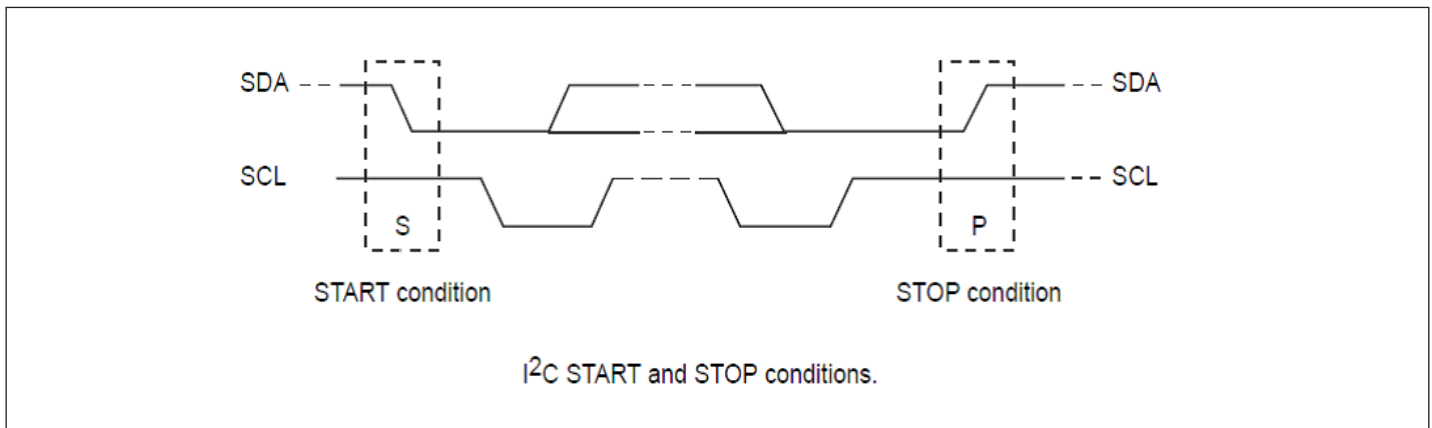

I²C Data Transfer

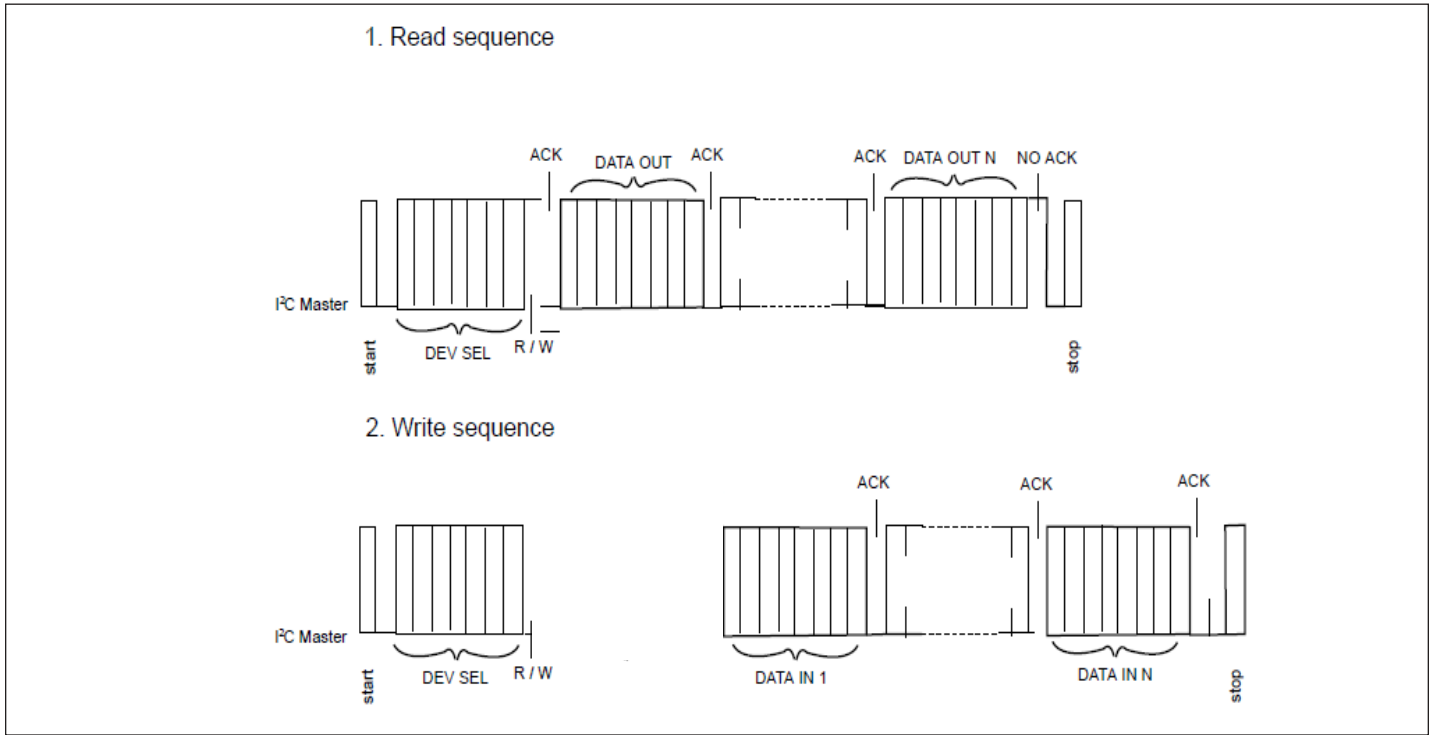

Maximum Ratings

(Above which useful life may be impaired. For user guidelines, not tested.)

Storage Temperature	-65°C to +150°C
Supply Voltage to Ground Potential	-0.5V to +4.6V
DC SIG Voltage	-0.5V to $V_{CC}+0.5V$
Output Current	-25mA to +25mA
Power Dissipation Continuous	2.1W
Junction Temperature T_j	125°C
ESD, HBM	-2kV to +2kV

Note:

Stresses greater than those listed under MAXIMUM RATINGS may cause permanent damage to the device. This is a stress rating only and functional operation of the device at these or any other conditions above those indicated in the operational sections of this specification is not implied. Exposure to absolute maximum rating conditions for extended periods may affect reliability.

Electrical Characteristics:

LVC MOS I/O DC Specifications ($V_{CC} = 3.3 \pm 0.3V$, $T_A = -40$ to $85^\circ C$)

Symbol	Parameter	Conditions	Min.	Typ.	Max	Units
V_{IH}	DC input logic high		$V_{CC}/2 + 0.7$		$V_{CC} + 0.3$	V
V_{IL}	DC input logic low		-0.3		$V_{CC}/2 - 0.7$	V
V_{OH}	At $I_{OH} = -200\mu A$		$V_{CC} + 0.2$			V
V_{OL}	At $I_{OL} = -200\mu A$				0.2	V
V_{hys}	Hysteresis of Schmitt trigger input		0.8			V

SDA and SCL I/O for I2C-bus ($V_{CC} = 3.3 \pm 0.3V$, $T_A = -40$ to $85^\circ C$)

Symbol	Parameter	Conditions	Min.	Typ.	Max.	Units
V_{IH}	DC input logic high		$V_{CC}/2 + 0.7$		$V_{CC} + 0.3$	V
V_{IL}	DC input logic low		-0.3		$V_{CC}/2 - 0.7$	V
V_{OL}	DC output logic low	$I_{OL} = 3mA$			0.4	V
V_{hys}	Hysteresis of Schmitt trigger input		0.8			V
t_{of}	Output fall time from V_{IHmin} to V_{ILmax} with bus cap. 10-400pF				250	ns
f_{SCLK}	SCLK clock frequency				100	kHz

High Speed I/O AC/DC Specifications ($V_{CC} = 3.3 \pm 0.3V$, $T_A = -40$ to $85^\circ C$)

Symbol	Parameter	Conditions	Min.	Typ.	Max.	Units
C_{RX}	RX AC coupling capacitance			220		nF
S_{11}	Input return loss	10MHz to 6GHz differential		11.0		dB
		1GHz to 6GHz common mode		5.0		
S_{22}	Output return loss	10MHz to 6GHz differential		11.5		dB
		1GHz to 6GHz common mode		4.8		
R_{IN}	DC single-ended input impedance			50		Ω
	DC Differential Input Impedance			100		

High Speed I/O AC/DC Specifications Cont.

Symbol	Parameter	Conditions	Min.	Typ.	Max.	Units
R _{OUT}	DC single-ended output impedance			50		Ω
	DC Differential output Impedance			100		
Z _{RX-HIZ}	DC input CM input impedance during reset or power down			200		kΩ
V _{RX-DIFF-PP}	Differential Input Peak-to-peak Voltage	Operational			1.2	V _{ppd}
	Input source common-mode noise	DC – 200MHz			150	mV _{pp}
T _{TX-IDLE-SET-TO-IDLE}	Max time to electrical idle after sending an EIOS			4	8	ns
T _{TX-IDLE-TO-DIFF-DATA}	Max time to valid diff signal after leaving electrical idle			4	8	ns
V _{CC}	Power supply voltage		3	3.3	3.6	V
P _{max}	Max Supply power	PRSNT#=0			1.3	W
I _{max}	Max Supply current				360	mA
P _{idle}	Supply power	PRSNT#=1			14.4	mW
t _{pd}	Latency	From input to output		0.5		ns
G _p	Peaking gain (Compensation at 6GHz, relative to 100MHz, 100mVp-p sine wave input)	EQ<3:0> = 1111		15.4		dB
		EQ<3:0> = 1000		12.5		
		EQ<3:0> = 0000		7.1		
		Variation around typical	-3		+3	dB
G _F	Flat gain (100MHz, EQ<3:0> = 1000, SW<1:0> = 10)	FG<1:0> = 11		2		dB
		FG<1:0> = 10		0		
		FG<1:0> = 01		-2		
		FG<1:0> = 00		-4		
		Variation around typical	-3		+3	dB
V _{1dB_100M}	-1dB compression point of output swing (at 100MHz)	SW<1:0> = 11		1370		mV _{ppd}
		SW<1:0> = 10		1280		
		SW<1:0> = 01		1040		
		SW<1:0> = 00		920		
V _{1dB_6G}	-1dB compression point of output swing (at 6GHz)	SW<1:0> = 11		1000		mV _{ppd}
		SW<1:0> = 10		940		
		SW<1:0> = 01		700		
		SW<1:0> = 00		600		
V _{Coup}	Channel isolation	100MHz to 6GHz ⁽¹⁾ , Figure 1		25		dB

High Speed I/O AC/DC Specifications Cont.

Symbol	Parameter	Conditions	Min.	Typ.	Max.	Units
Vnoise_input	Input-referred noise	100MHz to 6GHz, FG<1:0> = 11, EQ<3:0> = 0000, Figure 2		0.5		mV _{RMS}
		100MHz to 6GHz, FG<1:0> = 11, EQ<3:0> = 1010, Figure 2		0.4		
Vnoise_output	Output-referred noise ⁽²⁾	100MHz to 6GHz, FG<1:0> = 11, EQ<3:0> = 0000, Figure 2		0.7		mV _{RMS}
		100MHz to 6GHz, FG<1:0> = 11, EQ<3:0> = 1010, Figure 2		0.8	1.6	

Note: (1) Measured using a vector-network analyzer (VNA) with -15dBm power level applied to the adjacent input. The VNA detects the signal at the output of the victim channel. All other inputs and outputs are terminated with 50Ω.

(2) Guaranteed by design and characterization.

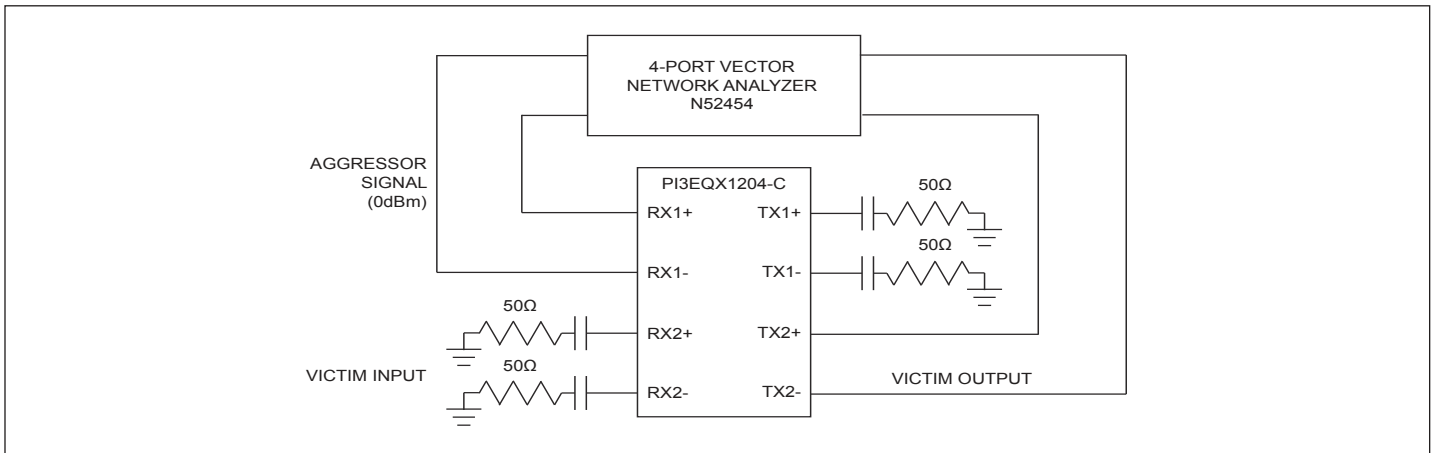

Figure 1. Channel-Isolation Test Configuration

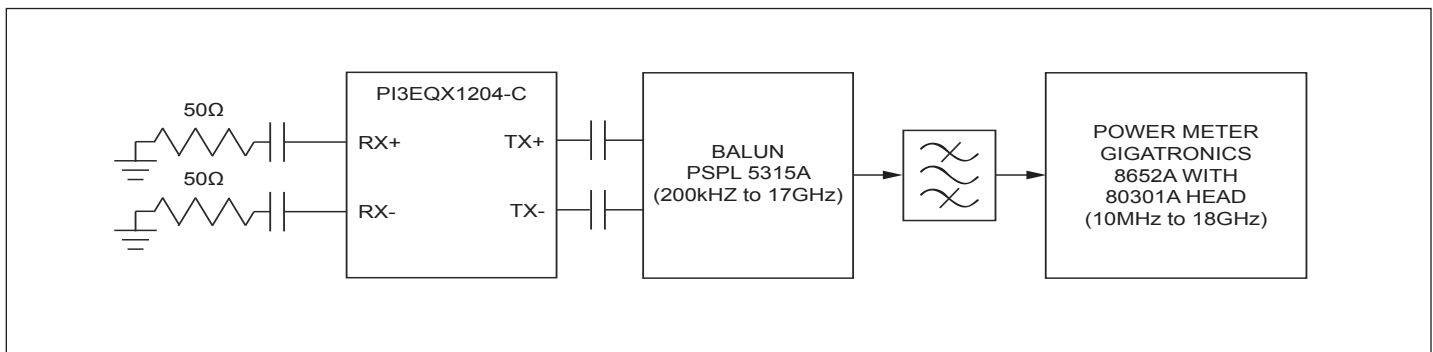
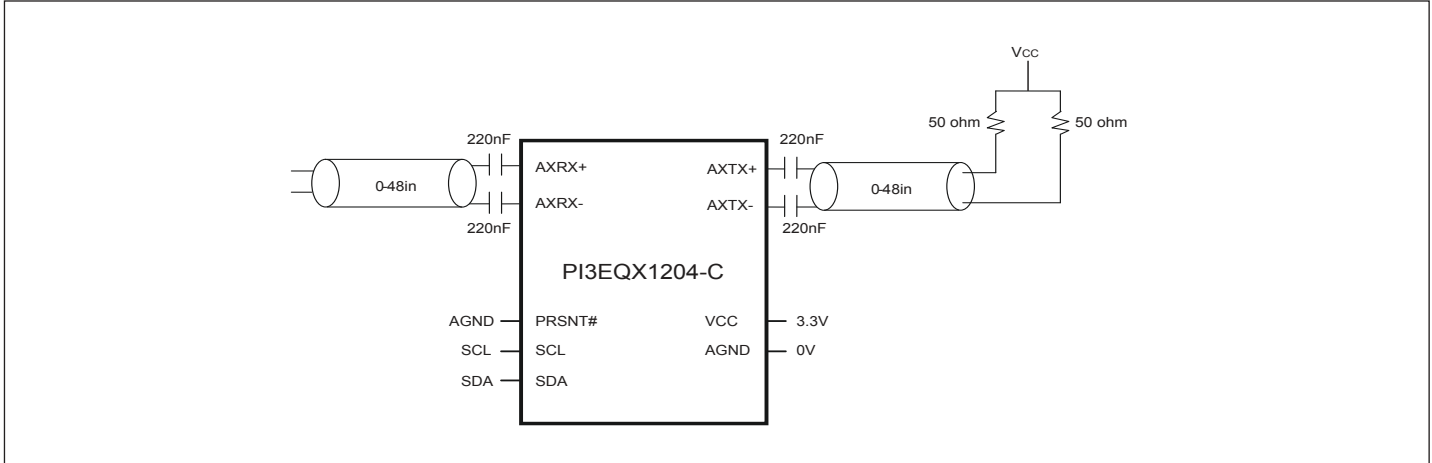

Figure 2. Noise Test Configuration

ESD Specification

- 2000V HBM
- 500V CDM

Application Diagram



AC/DC Specifications - SCL/SDA for I²C BUS

Symbol	Parameter	Conditions	Min.	Typ.	Max	Units
V _{IH}	DC input logic high		V _{CC} /2 + 0.7		V _{CC} + 0.3	V
V _{IL}	DC input logic low		-0.3		V _{CC} /2 - 0.7	V
V _{OL}	DC output logic low	I _{OL} = 3mA			0.4	V
I _{pullup}	Current Through Pull-Up Resistor or Current Source	High Power specification	3.0		3.6	mA
V _{DD}	Nominal Bus Voltage		3.0		3.6	V
I _{leak-bus}	Input leakage per bus segment		-200		200	uA
I _{leak-pin}	Input leakage per device pin			-15		uA
CI	Capacitance for SDA/SCL				10	pF
Freq	Bus Operation Frequency				100k	Hz
T _{BUF}	"Bus Free Time Between Stop and Start condition"		1.3			us
T _{HD:STA}	Hold time after (Repeated) Start condition. After this period, the first clock is generated.	At I _{pull-up} , Max	0.6			us
T _{SU:STA}	Repeated start condition setup time		0.6			us
T _{SU:STO}	Stop condition setup time		0.6			us
T _{HD:DAT}	Data hold time		0			ns
T _{SU:DAT}	Data setup time		100			ns
T _{low}	Clock low period		1.3			us
T _{high}	Clock high period		0.6		50	us
t _F	Clock/Data fall time				300	ns
t _R	Clock/Data rise time				300	ns
t _{por}	"Time in which a device must be operation after power-on reset"				500	ms

Note: (1) Recommended value.

(2) Recommended maximum capacitance load per bus segment is 400pF.

(3) Compliant to I²C physical layer specification.

(4) Ensured by Design. Parameter not tested in production.

Part Marking

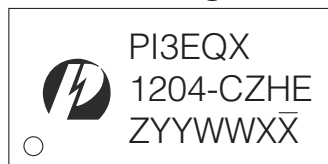

Z: Die Rev

YY: Year

WW: Workweek

1st X: Assembly Code

2nd X: Fab Code

Package Mechanical: 42-TQFN (ZH)

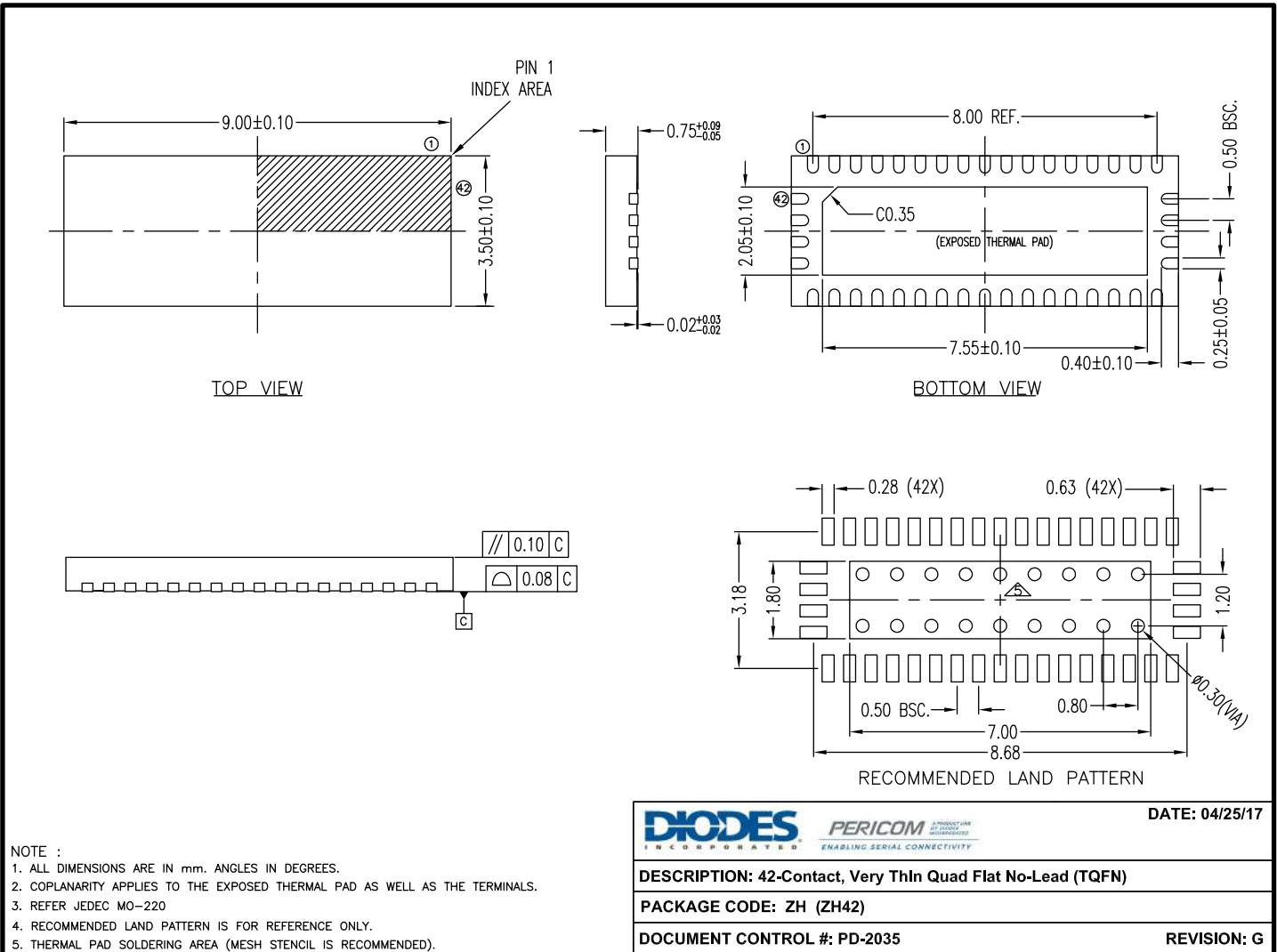

17-0266

For latest package info.

please check: <http://www.diodes.com/design/support/packaging/pericom-packaging/packaging-mechanicals-and-thermal-characteristics/>

Ordering Information

Ordering Number	Package Code	Package Description
PI3EQX1204-CZHEX	ZH	42-Contact, Very Thin Quad Flat No-Lead (TQFN)

Notes:

1. No purposely added lead. Fully EU Directive 2002/95/EC (RoHS), 2011/65/EU (RoHS 2) & 2015/863/EU (RoHS 3) compliant.
2. See <https://www.diodes.com/quality/lead-free/> for more information about Diodes Incorporated's definitions of Halogen- and Antimony-free, "Green" and Lead-free.
3. Halogen- and Antimony-free "Green" products are defined as those which contain <900ppm bromine, <900ppm chlorine (<1500ppm total Br + Cl) and <1000ppm antimony compounds.
4. E = Pb-free and Green
5. X suffix = Tape/Reel

IMPORTANT NOTICE

1. DIODES INCORPORATED AND ITS SUBSIDIARIES (“DIODES”) MAKE NO WARRANTY OF ANY KIND, EXPRESS OR IMPLIED, WITH REGARDS TO ANY INFORMATION CONTAINED IN THIS DOCUMENT, INCLUDING, BUT NOT LIMITED TO, THE IMPLIED WARRANTIES OF MERCHANTABILITY, FITNESS FOR A PARTICULAR PURPOSE OR NON-INFRINGEMENT OF THIRD PARTY INTELLECTUAL PROPERTY RIGHTS (AND THEIR EQUIVALENTS UNDER THE LAWS OF ANY JURISDICTION).

2. The Information contained herein is for informational purpose only and is provided only to illustrate the operation of Diodes products described herein and application examples. Diodes does not assume any liability arising out of the application or use of this document or any product described herein. This document is intended for skilled and technically trained engineering customers and users who design with Diodes products. Diodes products may be used to facilitate safety-related applications; however, in all instances customers and users are responsible for (a) selecting the appropriate Diodes products for their applications, (b) evaluating the suitability of the Diodes products for their intended applications, (c) ensuring their applications, which incorporate Diodes products, comply the applicable legal and regulatory requirements as well as safety and functional-safety related standards, and (d) ensuring they design with appropriate safeguards (including testing, validation, quality control techniques, redundancy, malfunction prevention, and appropriate treatment for aging degradation) to minimize the risks associated with their applications.

3. Diodes assumes no liability for any application-related information, support, assistance or feedback that may be provided by Diodes from time to time. Any customer or user of this document or products described herein will assume all risks and liabilities associated with such use, and will hold Diodes and all companies whose products are represented herein or on Diodes' websites, harmless against all damages and liabilities.

4. Products described herein may be covered by one or more United States, international or foreign patents and pending patent applications. Product names and markings noted herein may also be covered by one or more United States, international or foreign trademarks and trademark applications. Diodes does not convey any license under any of its intellectual property rights or the rights of any third parties (including third parties whose products and services may be described in this document or on Diodes' website) under this document.

5. Diodes products are provided subject to Diodes' Standard Terms and Conditions of Sale (<https://www.diodes.com/about/company/terms-and-conditions/terms-and-conditions-of-sales/>) or other applicable terms. This document does not alter or expand the applicable warranties provided by Diodes. Diodes does not warrant or accept any liability whatsoever in respect of any products purchased through unauthorized sales channel.

6. Diodes products and technology may not be used for or incorporated into any products or systems whose manufacture, use or sale is prohibited under any applicable laws and regulations. Should customers or users use Diodes products in contravention of any applicable laws or regulations, or for any unintended or unauthorized application, customers and users will (a) be solely responsible for any damages, losses or penalties arising in connection therewith or as a result thereof, and (b) indemnify and hold Diodes and its representatives and agents harmless against any and all claims, damages, expenses, and attorney fees arising out of, directly or indirectly, any claim relating to any noncompliance with the applicable laws and regulations, as well as any unintended or unauthorized application.

7. While efforts have been made to ensure the information contained in this document is accurate, complete and current, it may contain technical inaccuracies, omissions and typographical errors. Diodes does not warrant that information contained in this document is error-free and Diodes is under no obligation to update or otherwise correct this information. Notwithstanding the foregoing, Diodes reserves the right to make modifications, enhancements, improvements, corrections or other changes without further notice to this document and any product described herein. This document is written in English but may be translated into multiple languages for reference. Only the English version of this document is the final and determinative format released by Diodes.

8. Any unauthorized copying, modification, distribution, transmission, display or other use of this document (or any portion hereof) is prohibited. Diodes assumes no responsibility for any losses incurred by the customers or users or any third parties arising from any such unauthorized use.

Copyright © 2021 Diodes Incorporated

www.diodes.com