

**molex**

**Mini-Mac  
Applicator  
Air Feed-Mylar Tape**

## Application Tooling Specification Sheet

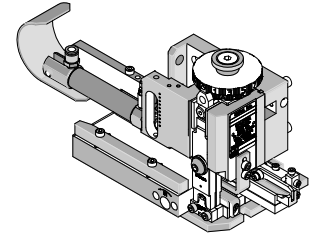

**Order No. 63885-3800**

### FEATURES

Directly adapts to most crimp presses and automatic wire processors  
 Applicator designed to industry-standard mounting and shut height of 135.80mm (5.346")  
 Conductor and insulation rings allow quick adjustment for conductor and insulation crimp height change  
 Quick set-up time; plus the crimp height, track and feed adjustments can be set without removing the applicator from the crimp press

### SCOPE

Products: Krimptite™ / Versakrimp™ Ring, Spade, Rectangular, Hook, Flanged, and Wire Pin Terminals  
 18-22 AWG.

#### Testing

##### Mechanical

The tensile test, or pull test, is a means of evaluating the mechanical properties of the crimped connections. The following chart shows the UL and government specifications (MIL-T-7928) for various wire sizes. The tensile strength is shown in pounds and indicates the minimum acceptable force to break or separate the terminal from the conductor.

Color Code	Wire Size (AWG)	*UL - 486 A	*UL - 486 C	*UL - 310	*Military Class 2
Red	22	8	8	8	15
Red	20	13	10	13	19
Red	18	20	10	20	38

\*UL - 486 A - Terminals (Copper conductors only)

\*UL - 486 C - Butt Splices, Parallel Splices, Closed End Connectors, and Wire Nuts

\*UL - 310 - Quick Disconnects, Flag and Couplers

\*Military Class 2- Military Approved Terminals only as listed

## Product List

The following is a partial list of the product order numbers and their specifications that this tool is designed to run. Updates to this list are available on [www.molex.com](http://www.molex.com).

Terminal Order No.	Terminal Eng. No.	Wire Size		Insulation Diameter Maximum		Strip Length	
		AWG	mm <sup>2</sup>	mm	In	mm	In
19069-0026	AA-1111-04T	18-22	0.80-0.35	N/A	N/A	4.76	.187
19069-0028	AA-120-02T	18-22	0.80-0.35	N/A	N/A	4.76	.187
19069-0030	AA-120-04T	18-22	0.80-0.35	N/A	N/A	4.76	.187
19069-0032	AA-120-06T	18-22	0.80-0.35	N/A	N/A	4.76	.187
19069-0034	AA-121-06T	18-22	0.80-0.35	N/A	N/A	4.76	.187
19069-0036	AA-121-08T	18-22	0.80-0.35	N/A	N/A	4.76	.187
19069-0038	AA-121-10T	18-22	0.80-0.35	N/A	N/A	4.76	.187
19069-0041	AA-122-10T	18-22	0.80-0.35	N/A	N/A	4.76	.187
19069-0044	AA-122-14T	18-22	0.80-0.35	N/A	N/A	4.76	.187
19069-0046	AA-122-56T	18-22	0.80-0.35	N/A	N/A	4.76	.187
19069-0050	AA-126-38T	18-22	0.80-0.35	N/A	N/A	4.76	.187
19069-0053	AA-132-04T	18-22	0.80-0.35	N/A	N/A	4.76	.187
19069-0055	AA-132-06T	18-22	0.80-0.35	N/A	N/A	4.76	.187
19069-0057	AA-132-08T	18-22	0.80-0.35	N/A	N/A	4.76	.187
19069-0062	AA-133-10T	18-22	0.80-0.35	N/A	N/A	4.76	.187
19069-0127	AA-126-10T	18-22	0.80-0.35	N/A	N/A	4.76	.187
19069-0128	AA-126-14T	18-22	0.80-0.35	N/A	N/A	4.76	.187
19069-0129	AA-126-56T	18-22	0.80-0.35	N/A	N/A	4.76	.187
19069-0130	AA-132-10T	18-22	0.80-0.35	N/A	N/A	4.76	.187
19069-0191	AA-1111-02T	18-22	0.80-0.35	N/A	N/A	4.76	.187
19087-0030	AA-105-04T	18-22	0.80-0.35	N/A	N/A	4.76	.187
19087-0032	AA-105-06T	18-22	0.80-0.35	N/A	N/A	4.76	.187
19087-0038	AA-1110-02T	18-22	0.80-0.35	N/A	N/A	4.76	.187
19087-0040	AA-1110-04T	18-22	0.80-0.35	N/A	N/A	4.76	.187
19087-0042	AA-114-04T	18-22	0.80-0.35	N/A	N/A	4.76	.187
19087-0044	AA-114-06T	18-22	0.80-0.35	N/A	N/A	4.76	.187
19087-0046	AA-114-08T	18-22	0.80-0.35	N/A	N/A	4.76	.187
19087-0055	AA-192-06T	18-22	0.80-0.35	N/A	N/A	4.76	.187
19087-0057	AA-192-08T	18-22	0.80-0.35	N/A	N/A	4.76	.187
19087-0059	AA-192-10T	18-22	0.80-0.35	N/A	N/A	4.76	.187
19087-0061	AA-195-06T	18-22	0.80-0.35	N/A	N/A	4.76	.187
19087-0063	AA-195-08T	18-22	0.80-0.35	N/A	N/A	4.76	.187
19087-0065	AA-195-10T	18-22	0.80-0.35	N/A	N/A	4.76	.187
19087-0067	AA-198-04T	18-22	0.80-0.35	N/A	N/A	4.76	.187
19087-0069	AA-198-06T	18-22	0.80-0.35	N/A	N/A	4.76	.187
19087-0071	AA-198-08T	18-22	0.80-0.35	N/A	N/A	4.76	.187
19087-0073	AA-198-10T	18-22	0.80-0.35	N/A	N/A	4.76	.187
19093-0002	AA-305-04T	18-22	0.80-0.35	N/A	N/A	4.76	.187
19093-0004	AA-305-06T	18-22	0.80-0.35	N/A	N/A	4.76	.187
19093-0010	AA-3110-02T	18-22	0.80-0.35	N/A	N/A	4.76	.187
19093-0012	AA-3110-04T	18-22	0.80-0.35	N/A	N/A	4.76	.187
19093-0014	AA-314-04T	18-22	0.80-0.35	N/A	N/A	4.76	.187
19093-0016	AA-314-06T	18-22	0.80-0.35	N/A	N/A	4.76	.187
19093-0018	AA-314-08T	18-22	0.80-0.35	N/A	N/A	4.76	.187
19093-0020	AA-392-06T	18-22	0.80-0.35	N/A	N/A	4.76	.187
19093-0022	AA-392-08T	18-22	0.80-0.35	N/A	N/A	4.76	.187
19093-0024	AA-392-10T	18-22	0.80-0.35	N/A	N/A	4.76	.187
19093-0026	AA-395-06T	18-22	0.80-0.35	N/A	N/A	4.76	.187
19093-0028	AA-395-08T	18-22	0.80-0.35	N/A	N/A	4.76	.187
19093-0030	AA-395-10T	18-22	0.80-0.35	N/A	N/A	4.76	.187
19093-0032	AA-398-04T	18-22	0.80-0.35	N/A	N/A	4.76	.187
19093-0034	AA-398-06T	18-22	0.80-0.35	N/A	N/A	4.76	.187
19093-0036	AA-398-08T	18-22	0.80-0.35	N/A	N/A	4.76	.187
19093-0038	AA-398-10T	18-22	0.80-0.35	N/A	N/A	4.76	.187
19098-0012	AA-1190-06T	18-22	0.80-0.35	N/A	N/A	4.76	.187
19098-0014	AA-1191-08T	18-22	0.80-0.35	N/A	N/A	4.76	.187
19098-0016	AA-1192-10T	18-22	0.80-0.35	N/A	N/A	4.76	.187

Terminal Order No.	Terminal Eng. No.	Wire Size		Insulation Diameter Maximum		Strip Length	
		AWG	mm <sup>2</sup>	mm	In	mm	In
19098-0019	AA-1704-06T	18-22	0.80-0.35	N/A	N/A	4.76	.187
19098-0076	AA-1704-04T	18-22	0.80-0.35	N/A	N/A	4.76	.187
19098-0077	AA-1704-05T	18-22	0.80-0.35	N/A	N/A	4.76	.187
19098-0078	AA-1705-08T	18-22	0.80-0.35	N/A	N/A	4.76	.187
19098-0079	AA-1706-10T	18-22	0.80-0.35	N/A	N/A	4.76	.187
19098-0080	AA-1714-08T	18-22	0.80-0.35	N/A	N/A	4.76	.187
19098-0081	AA-1715-10T	18-22	0.80-0.35	N/A	N/A	4.76	.187
19118-0022	AA-115-06T	18-22	0.80-0.35	N/A	N/A	4.76	.187
19118-0024	AA-115-08T	18-22	0.80-0.35	N/A	N/A	4.76	.187
19118-0036	AA-193-10T	18-22	0.80-0.35	N/A	N/A	4.76	.187
19118-0095	AA-1108-02T	18-22	0.80-0.35	N/A	N/A	4.76	.187
19118-0096	AA-1108-04T	18-22	0.80-0.35	N/A	N/A	4.76	.187
19118-0097	AA-115-02T	18-22	0.80-0.35	N/A	N/A	4.76	.187
19118-0098	AA-115-04T	18-22	0.80-0.35	N/A	N/A	4.76	.187
19118-0099	AA-115-10T	18-22	0.80-0.35	N/A	N/A	4.76	.187
19118-0100	AA-1461-06T	18-22	0.80-0.35	N/A	N/A	4.76	.187
19118-0101	AA-1461-08T	18-22	0.80-0.35	N/A	N/A	4.76	.187
19118-0103	AA-190-06T	18-22	0.80-0.35	N/A	N/A	4.76	.187
19118-0104	AA-190-08T	18-22	0.80-0.35	N/A	N/A	4.76	.187
19118-0105	AA-190-10T	18-22	0.80-0.35	N/A	N/A	4.76	.187
19118-0106	AA-193-06T	18-22	0.80-0.35	N/A	N/A	4.76	.187
19118-0107	AA-193-08T	18-22	0.80-0.35	N/A	N/A	4.76	.187
19118-0108	AA-196-04T	18-22	0.80-0.35	N/A	N/A	4.76	.187
19118-0109	AA-196-06T	18-22	0.80-0.35	N/A	N/A	4.76	.187
19118-0110	AA-196-08T	18-22	0.80-0.35	N/A	N/A	4.76	.187
19124-0002	AA-3108-02T	18-22	0.80-0.35	N/A	N/A	4.76	.187
19124-0004	AA-3108-04T	18-22	0.80-0.35	N/A	N/A	4.76	.187
19124-0006	AA-315-04T	18-22	0.80-0.35	N/A	N/A	4.76	.187
19124-0008	AA-315-06T	18-22	0.80-0.35	N/A	N/A	4.76	.187
19124-0010	AA-315-08T	18-22	0.80-0.35	N/A	N/A	4.76	.187
19124-0016	AA-390-06T	18-22	0.80-0.35	N/A	N/A	4.76	.187
19124-0018	AA-390-08T	18-22	0.80-0.35	N/A	N/A	4.76	.187
19124-0020	AA-390-10T	18-22	0.80-0.35	N/A	N/A	4.76	.187
19124-0022	AA-393-06T	18-22	0.80-0.35	N/A	N/A	4.76	.187
19124-0024	AA-393-08T	18-22	0.80-0.35	N/A	N/A	4.76	.187
19124-0026	AA-393-10T	18-22	0.80-0.35	N/A	N/A	4.76	.187
19124-0028	AA-396-04T	18-22	0.80-0.35	N/A	N/A	4.76	.187
19124-0030	AA-396-06T	18-22	0.80-0.35	N/A	N/A	4.76	.187
19124-0032	AA-396-08T	18-22	0.80-0.35	N/A	N/A	4.76	.187
19129-0034	AA-194-10T	18-22	0.80-0.35	N/A	N/A	4.76	.187
19129-0038	AA-138-06T	18-22	0.80-0.35	N/A	N/A	4.76	.187
19129-0040	AA-138-04T	18-22	0.80-0.35	N/A	N/A	4.76	.187
19129-0042	AA-134-10T	18-22	0.80-0.35	N/A	N/A	4.76	.187
19129-0044	AA-134-08T	18-22	0.80-0.35	N/A	N/A	4.76	.187
19129-0046	AA-134-06T	18-22	0.80-0.35	N/A	N/A	4.76	.187
19129-0050	AA-1118-06T	18-22	0.80-0.35	N/A	N/A	4.76	.187
19129-0052	AA-1109-04T	18-22	0.80-0.35	N/A	N/A	4.76	.187
19129-0054	AA-1109-02T	18-22	0.80-0.35	N/A	N/A	4.76	.187
19129-0060	AA-1118-08T	18-22	0.80-0.35	N/A	N/A	4.76	.187
19129-0061	AA-134-04T	18-22	0.80-0.35	N/A	N/A	4.76	.187
19129-0062	AA-191-06T	18-22	0.80-0.35	N/A	N/A	4.76	.187
19129-0063	AA-191-08T	18-22	0.80-0.35	N/A	N/A	4.76	.187
19129-0064	AA-191-10T	18-22	0.80-0.35	N/A	N/A	4.76	.187
19129-0065	AA-194-06T	18-22	0.80-0.35	N/A	N/A	4.76	.187
19129-0066	AA-194-08T	18-22	0.80-0.35	N/A	N/A	4.76	.187
19129-0067	AA-197-04T	18-22	0.80-0.35	N/A	N/A	4.76	.187
19129-0068	AA-197-08T	18-22	0.80-0.35	N/A	N/A	4.76	.187

Terminal Order No.	Terminal Eng. No.	Wire Size		Insulation Diameter Maximum		Strip Length	
		AWG	mm <sup>2</sup>	mm	In	mm	In
19135-0003	AA-3109-04T	18-22	0.80-0.35	N/A	N/A	4.76	.187
19135-0004	AA-334-10T	18-22	0.80-0.35	N/A	N/A	4.76	.187
19135-0005	AA-3109-02T	18-22	0.80-0.35	N/A	N/A	4.76	.187
19141-0021	AA-135-06T	18-22	0.80-0.35	N/A	N/A	4.76	.187
19141-0023	AA-135-08T	18-22	0.80-0.35	N/A	N/A	4.76	.187
19141-0025	AA-135-10T	18-22	0.80-0.35	N/A	N/A	4.76	.187
19141-0026	AA-138-08T	18-22	0.80-0.35	N/A	N/A	4.76	.187
19147-0005	AA-334-04T	18-22	0.80-0.35	N/A	N/A	4.76	.187
19147-0007	AA-334-06T	18-22	0.80-0.35	N/A	N/A	4.76	.187
19147-0009	AA-334-08T	18-22	0.80-0.35	N/A	N/A	4.76	.187
19147-0012	AA-335-06T	18-22	0.80-0.35	N/A	N/A	4.76	.187
19147-0014	AA-335-08T	18-22	0.80-0.35	N/A	N/A	4.76	.187
19147-0016	AA-335-10T	18-22	0.80-0.35	N/A	N/A	4.76	.187
19147-0018	AA-338-04T	18-22	0.80-0.35	N/A	N/A	4.76	.187
19147-0020	AA-338-06T	18-22	0.80-0.35	N/A	N/A	4.76	.187
19147-0021	AA-338-08T	18-22	0.80-0.35	N/A	N/A	4.76	.187
19147-0023	AA-391-06T	18-22	0.80-0.35	N/A	N/A	4.76	.187
19147-0025	AA-391-08T	18-22	0.80-0.35	N/A	N/A	4.76	.187
19147-0027	AA-391-10T	18-22	0.80-0.35	N/A	N/A	4.76	.187
19147-0029	AA-394-06T	18-22	0.80-0.35	N/A	N/A	4.76	.187
19147-0031	AA-394-08T	18-22	0.80-0.35	N/A	N/A	4.76	.187
19147-0033	AA-394-10T	18-22	0.80-0.35	N/A	N/A	4.76	.187
19147-0035	AA-397-04T	18-22	0.80-0.35	N/A	N/A	4.76	.187
19147-0037	AA-397-06T	18-22	0.80-0.35	N/A	N/A	4.76	.187
19147-0039	AA-397-08T	18-22	0.80-0.35	N/A	N/A	4.76	.187
19178-0001	AA-110-04T	18-22	0.80-0.35	N/A	N/A	4.76	.187
19178-0003	AA-110-06T	18-22	0.80-0.35	N/A	N/A	4.76	.187
19178-0005	AA-110-08T	18-22	0.80-0.35	N/A	N/A	4.76	.187
19178-0007	AA-110-10T	18-22	0.80-0.35	N/A	N/A	4.76	.187
19180-0002	AA-310-06T	18-22	0.80-0.35	N/A	N/A	4.76	.187
19180-0004	AA-310-08T	18-22	0.80-0.35	N/A	N/A	4.76	.187
19180-0006	AA-310-10T	18-22	0.80-0.35	N/A	N/A	4.76	.187
19193-0008	AA-320-04T	18-22	0.80-0.35	N/A	N/A	4.76	.187
19193-0011	AA-320-06T	18-22	0.80-0.35	N/A	N/A	4.76	.187
19193-0013	AA-321-06T	18-22	0.80-0.35	N/A	N/A	4.76	.187

Terminal Order No.	Terminal Eng. No.	Wire Size		Insulation Diameter Maximum		Strip Length	
		AWG	mm <sup>2</sup>	mm	In	mm	In
19193-0015	AA-321-08T	18-22	0.80-0.35	N/A	N/A	4.76	.187
19193-0017	AA-321-10T	18-22	0.80-0.35	N/A	N/A	4.76	.187
19193-0018	AA-321-209	18-22	0.80-0.35	N/A	N/A	4.76	.187
19193-0020	AA-322-10T	18-22	0.80-0.35	N/A	N/A	4.76	.187
19193-0022	AA-322-14T	18-22	0.80-0.35	N/A	N/A	4.76	.187
19193-0024	AA-322-56T	18-22	0.80-0.35	N/A	N/A	4.76	.187
19193-0027	AA-326-14T	18-22	0.80-0.35	N/A	N/A	4.76	.187
19193-0029	AA-326-38T	18-22	0.80-0.35	N/A	N/A	4.76	.187
19193-0031	AA-326-56T	18-22	0.80-0.35	N/A	N/A	4.76	.187
19193-0033	AA-332-04T	18-22	0.80-0.35	N/A	N/A	4.76	.187
19193-0035	AA-332-06T	18-22	0.80-0.35	N/A	N/A	4.76	.187
19193-0037	AA-332-08T	18-22	0.80-0.35	N/A	N/A	4.76	.187
19193-0042	AA-T-320-04T	18-22	0.80-0.35	N/A	N/A	4.76	.187
19193-0045	AA-T-320-06T	18-22	0.80-0.35	N/A	N/A	4.76	.187
19193-0046	AA-T-322-14T	18-22	0.80-0.35	N/A	N/A	4.76	.187
19193-0047	AA-T-322-56T	18-22	0.80-0.35	N/A	N/A	4.76	.187
19193-0048	AA-T-326-38T	18-22	0.80-0.35	N/A	N/A	4.76	.187
19193-0050	AA-T-332-06T	18-22	0.80-0.35	N/A	N/A	4.76	.187
19193-0051	AA-T-332-08T	18-22	0.80-0.35	N/A	N/A	4.76	.187
19193-0052	AA-T-333-10T	18-22	0.80-0.35	N/A	N/A	4.76	.187
19193-0395	AA-3111-02T	18-22	0.80-0.35	N/A	N/A	4.76	.187
19193-0397	AA-3111-04T	18-22	0.80-0.35	N/A	N/A	4.76	.187
19193-0399	AA-320-02T	18-22	0.80-0.35	N/A	N/A	4.76	.187
19203-0026	AA-U-121-08T	18-22	0.80-0.35	N/A	N/A	4.76	.187
19203-0027	AA-U-122-14T	18-22	0.80-0.35	N/A	N/A	4.76	.187
19203-0028	AA-U-122-56T	18-22	0.80-0.35	N/A	N/A	4.76	.187
19203-0029	AA-U-126-38T	18-22	0.80-0.35	N/A	N/A	4.76	.187
19203-0031	AA-U-132-06T	18-22	0.80-0.35	N/A	N/A	4.76	.187
19203-0033	AA-U-132-08T	18-22	0.80-0.35	N/A	N/A	4.76	.187
19203-0035	AA-U-133-10T	18-22	0.80-0.35	N/A	N/A	4.76	.187
19203-0056	BB-T-318-38T	18-22	0.80-0.35	N/A	N/A	4.76	.187
19203-0059	BB-T-325-56T	18-22	0.80-0.35	N/A	N/A	4.76	.187
19211-0004	WP-1218T	18-22	0.80-0.35	N/A	N/A	4.76	.187

### DEFINITION OF TERMS

The following illustrations are a generic terminal representation and not an exact image of any terminal listed in the scope.

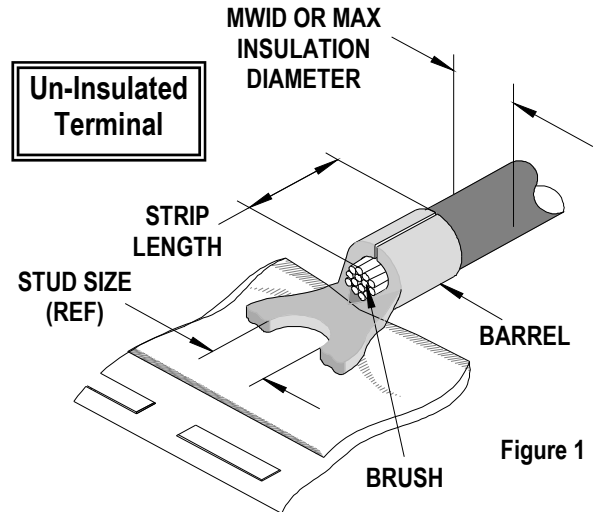
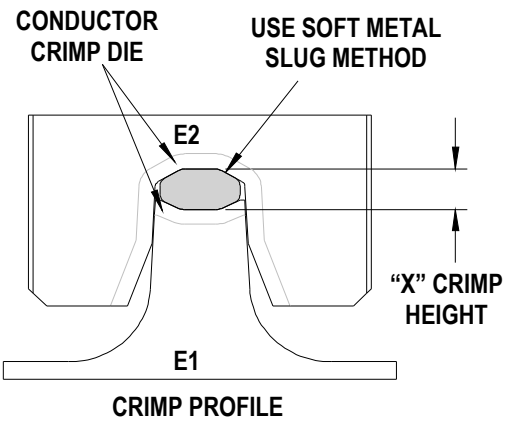

Figure 1

### Tool Calibration

To recalibrate this Applicator, make sure the power is completely shut off on the press.

1. The Mini-Mac applicator must be properly installed in the press.
2. Crimping dies must be properly installed in the Mini-Mac applicator.
3. The recommended method of measuring the crimp height of the conductor dies is the soft metal slug method, (See Figure 4).
4. The slug must have a diameter 0.51mm (.020") larger than the "X" No Go dimension before crimping.
5. Place the soft metal slug (solder) into the nest of the bottom die and crimp (by hand cycling the press) similar to a terminal. The crimp height can be measured with a blade type micrometer or dial caliper, (Dimension "X").
6. Adjustment of the crimp height can be accomplished by indexing the conductor cam. The letter "A" gives the loosest position and "K" gives the tightest position. A total adjustment of 0.50mm (.020") can be achieved by adjusting the conductor cam.



Use soft metal slug (solder) method to measure the "X" dimension. Verify tooling crimp height calibration by referring to the Go/No Go dimensions shown in the chart

Figure 2

**Note:** If the crimp height is too tight on the setting "A", check the shut height of the press. See the Industrial Mini-Mac Applicator Manual Section 2.1 for adjustments.

### CRIMP SPECIFICATIONS

Wire Size		"X" Dimension Conductor Crimp						Pull Force Minimum	
AWG	mm <sup>2</sup>	Mean		Go		No Go		Lbs	N
		In	mm	In	mm	In	mm		
22	0.32	.069	1.75	.066	1.67	.076	1.93	8.0	35.59
20	0.50	.069	1.75	.066	1.67	.076	1.93	13.0	57.83
18	0.80	.069	1.75	.066	1.67	.076	1.93	20.0	88.96

\* Tool Qualification Notes:

1. Pull Force should be measured with no influence from the insulation crimp.
2. The above specifications are guidelines to an optimum crimp.

**PARTS LIST**

<b>Mini-Mac Applicator 63885-3800</b>				
<b>Item</b>	<b>Order No</b>	<b>Engineering No.</b>	<b>Description</b>	<b>Quantity</b>
<b>Perishable Tooling</b>				
	63885-3870	63885-3870	Tool Kit (All "Y" Items)	REF
1	63465-0052	63465-0052	Conductor Punch	1 Y
2	63464-0052	63464-0052	Conductor Anvil	1 Y
<b>Other Components</b>				
3	63443-0021	63443-0021	Lower Tooling Key	1
4	63466-0912	63466-0912	Anvil Mount	1
5	63466-0913	63466-0913	Terminal Support	1
6	63466-0921	63466-0921	Terminal Stripping Blade	1
7	63600-1290	63600-1290	Washer	1
8	63890-0866	63890-0866	Collar-6.4mm Long	1
9	63890-0867	63890-0867	Collar-7.7mm Long	1
<b>Frame</b>				
10	63801-3301	63801-3301	Air Feed Applicator Frame Head	1
11	63801-3281	63801-3281	Base	1
12	63801-5850	63801-5850	Track Assembly	1
13	63801-3390	63801-3390	Air Kit	1
<b>Hardware</b>				
14	N/A	N/A	M3 by 12 Long SHCS	1**
15	N/A	N/A	M4 by 10 Long SHCS	2**
16	N/A	N/A	M4 by 16 Long SHCS	1**
17	N/A	N/A	M4 by 45 Long SHCS	1**
18	N/A	N/A	M8 by 30 Long BHCS	1**
19	N/A	N/A	3mm by 6 Long Roll Pin	1**

\*\* Available from an industrial supply company such as MSC (1-800-645-7270).

**Note:** Crimp profiles used in 63885-3800 are equivalent to 19027-0034 / ATP-AA-110 (UL file number E32244).

### Assembly Drawing

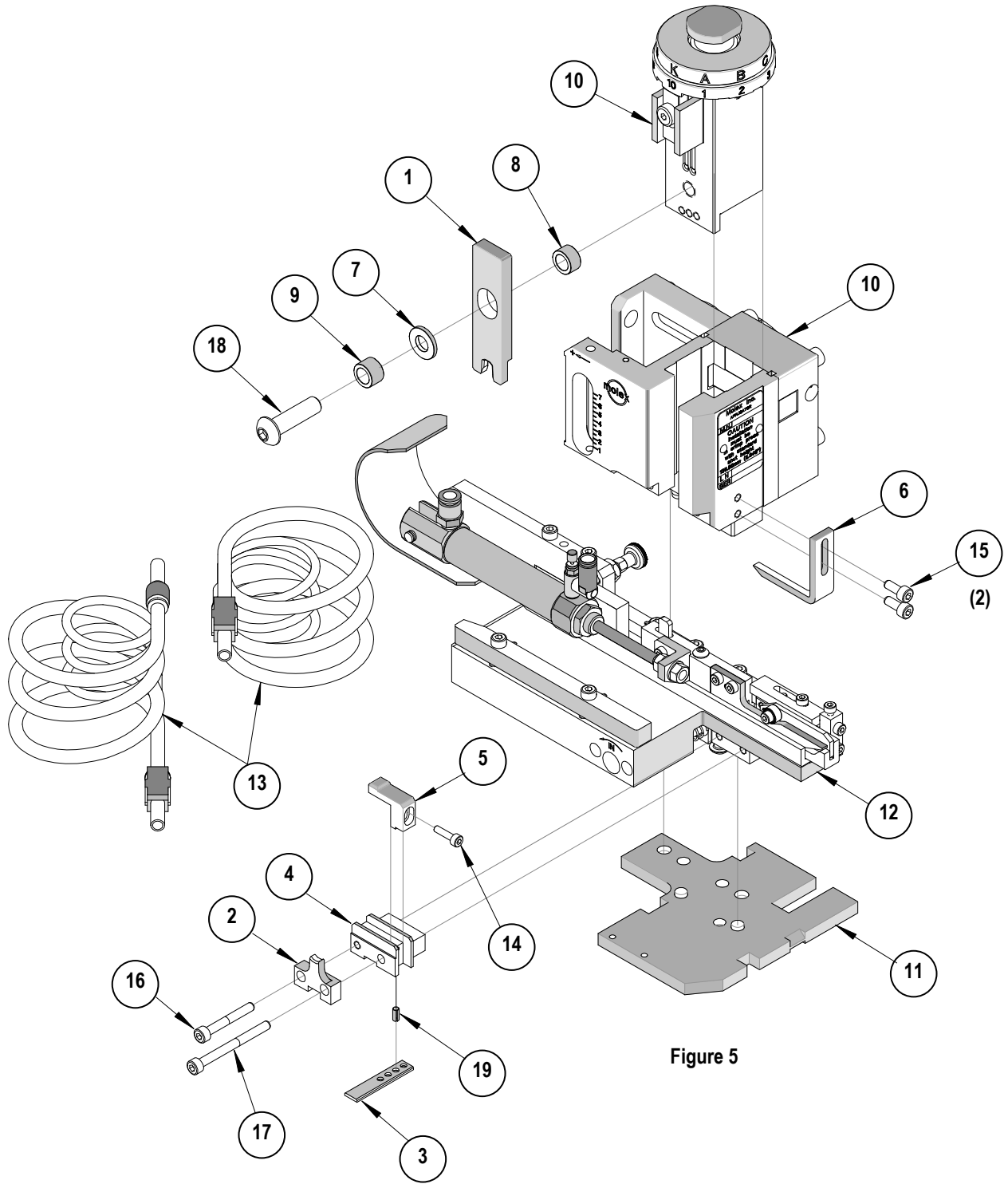

Figure 5

## NOTES

1. Molex recommends an extra perishable tooling kit be maintained at your facility.
2. Verify tooling alignment by manually cycling the press with applicator before crimping under power. Check that all screws are tight.
3. Slugs, terminals, dirt, and oil should be kept clear of work area.
4. Wear safety glasses at all times.
5. For recommended maintenance refer to the Mini-Mac Applicator Manual (Document no. 63880-0000).

**CAUTION:** This applicator should only be used in a press with a shut height of 135.80 mm (5.346"). Tooling damage could result at a lower setting.

**CAUTION:** To prevent injury, never operate this applicator without the guards supplied with the press or wire-processing machine in place. Reference the press or wire processing manufacturer's instruction manual.

**CAUTION:** Molex crimp specifications are valid only when used with Molex terminals, applicators and tooling.

## Contact Information

For more information on Molex application tooling please contact Molex at 1-800-786-6539.

<http://www.molex.com>