

LOC	DIST	REV	DESCRIPTION	DATE	OWN	APPD
DF	FO	C	REV & REDRAWN; 0600-4803-95	4-96	CT	DM
		D	REV PER 0600-5641-96 TT	09-97		DM

- 1 AMP, DATE CODE AND AMP PART NO. MARKED THIS APPROX AREA.
- 2 NUMBERS (SEE TABLE) INDICATING END CAVITIES MARKED ON MATING FACE. NUMBERS INDICATING EVERY 5 CAVITIES MARKED ON SIDE.
- 3 KEY POSITION IDENTIFICATION MOLDED ON SURFACE SHOWN.
- 4. PART HAS BEEN SEALED WITH AN EPOXY SEALANT.

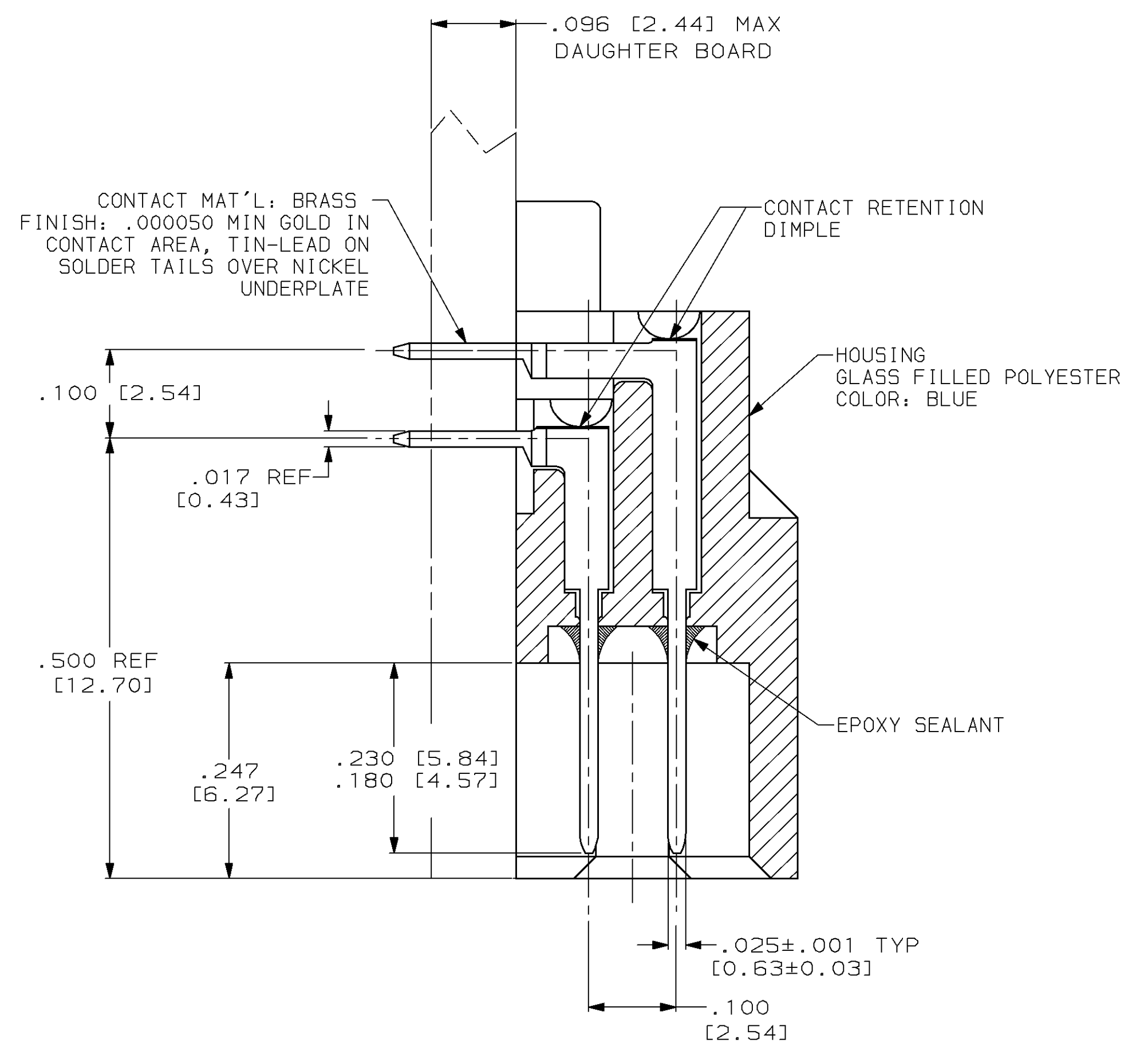

SECTION Y-Y
SCALE 8:1

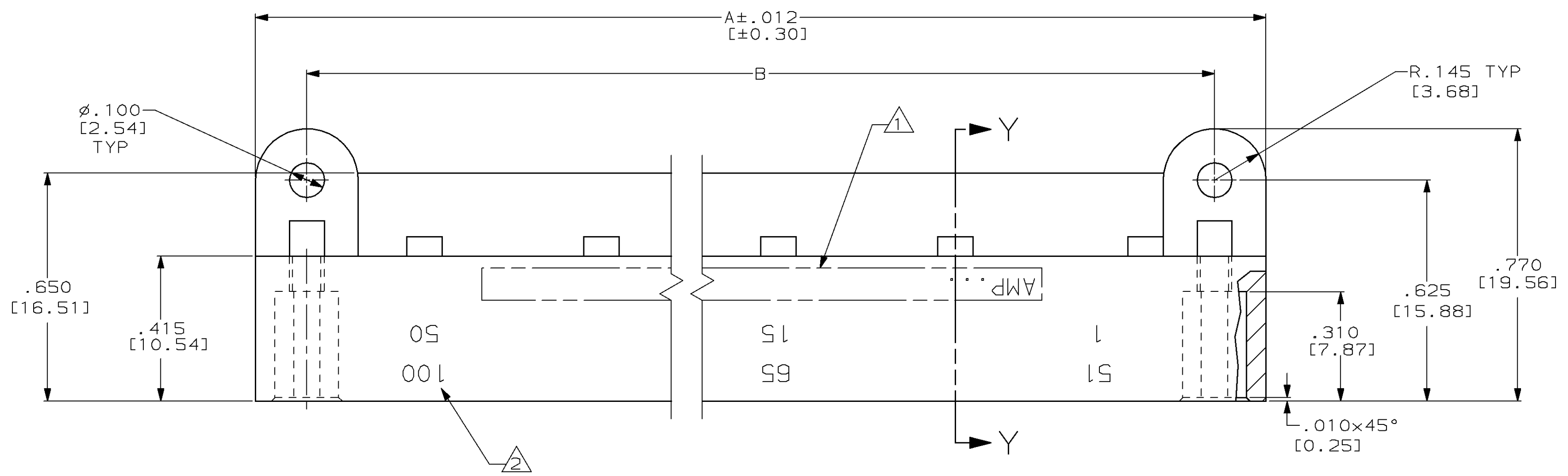
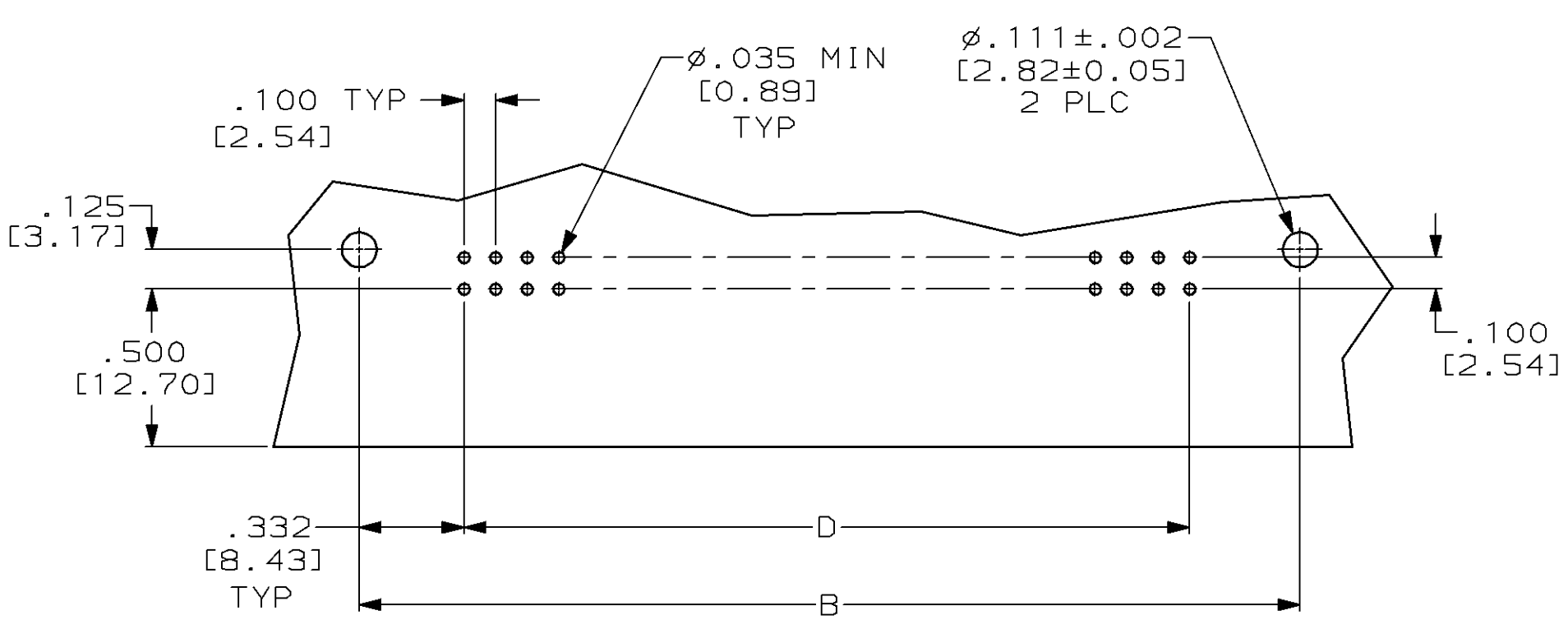
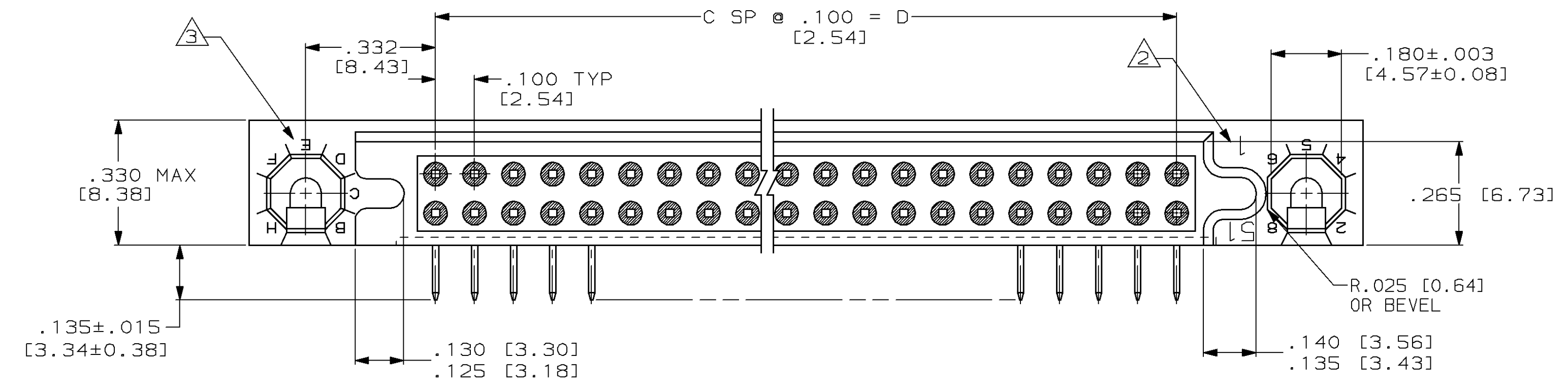

RECOMMENDED P.C. BOARD LAYOUT
SCALE 2:1

OBSOLETE	1	71	6.900 [175.26]	69	7.565 [192.15]	7.855 [199.52]	140	1-532795-3
OBSOLETE	1	68	6.600 [167.64]	66	7.265 [184.53]	7.555 [191.90]	134	1-532795-2
	1	66	6.400 [162.56]	64	7.065 [179.45]	7.355 [186.82]	130	1-532795-1
OBSOLETE	1	61	5.900 [149.86]	59	6.565 [141.35]	6.855 [174.12]	120	1-532795-0
OBSOLETE	1	51	4.900 [124.46]	49	5.565 [141.35]	5.855 [148.72]	100	532795-9
	1	46	4.400 [111.76]	44	5.065 [128.65]	5.355 [136.02]	90	532795-8
OBSOLETE	1	41	3.900 [99.06]	39	4.565 [115.95]	4.855 [123.32]	80	532795-7
OBSOLETE	1	36	3.400 [86.36]	34	4.065 [103.25]	4.355 [110.62]	70	532795-6
OBSOLETE	1	31	2.900 [73.66]	29	3.565 [90.55]	3.855 [97.92]	60	532795-5
	1	16	1.400 [35.56]	14	2.065 [52.45]	2.355 [59.82]	30	532795-4
	1	56	5.400 [137.16]	54	6.065 [154.05]	6.355 [161.42]	110	532795-3
OBSOLETE	1	26	2.400 [60.96]	24	3.065 [77.85]	3.355 [85.22]	50	532795-2
OBSOLETE	1	21	1.900 [48.26]	19	2.565 [65.15]	2.855 [72.51]	40	532795-1

CAVITY IDENT	D	C	B	A	NO OF POSN	PART NUMBER

THIS DRAWING IS A CONTROLLED DOCUMENT.

DIMENSIONS: (INCHES [mm])

TOLERANCES UNLESS OTHERWISE SPECIFIED:

0 PLC	±
1 PLC	±
2 PLC	±
3 PLC	±.010 [0.25]
4 PLC	±

ANGLES: ±

MATERIAL: SEE CALLOUTS

FINISH: SEE CALLOUTS

WEIGHT: -

CUSTOMER DRAWING

AMP Incorporated
Harrisburg, PA 17105-3608

AMP BOX PIN HDR ASSY, RT ANGLE
.100x.100. 1001 SERIES, SEALED

SIZE: A1
CAGE CODE: 00779
DRAWING NO: C-532795

SCALE: 4:1
SHEET: 1 of 1
REV: D