

4

3

2

DWG NO. GE-2158 SH 1 REV D

1

PROPRIETARY NOTICE: THE INFORMATION CONTAINED IN THIS DOCUMENT IS PROPRIETARY TO AMPHENOL AND SHALL NOT BE DISCLOSED IN WHOLE OR IN PART IN ANY FORM OR FOR ANY REASON EXCEPT AS EXPRESSLY STATED IN WRITING BY AMPHENOL.

NOTES:

- 1. CONTINUOUS OPERATING TEMPERATURE -40°C TO 150°C
- 2. CONNECTOR: METRI-PACK 150.2 OR GT150 3.5 mm MATING APTIV(DEPLHI) NUMBER: 12162193,15336004, OR EQUIVILANT
- 3. VOLTAGE: 5V
- 4. LOCTITE 503 , 516 OR 517 THREAD SEALANT APPLIED TO THE THREADS

TEMP (°C)	RESISTANCE (OHMS)	RES TOL (±%)
-40	100865	4.87
25	2795	2.50
50	980.3	2.27
85	283.5	2.00
125	88.3	2.75
128	81.7	2.77
150	47.5	2.90

REVISIONS				
REV	REVISION HISTORY	DATE	DWN	APVD
A	INITIAL RELEASE	6/04/18	MED	JD
B	85°C WAS 80°C ADDED 128°C ROW	11/01/18	MED	JD
C	ADDED NOTE # 4 ...THREAD SEALANT	11/29/18	MED	JD
D	UP-DATED NOTES & RES TBL, 28.6+/- .13 WAS 28.60, ULTEM 2300-BLACK WAS NYLON 66 GF 33%	5/31/19	MED	STS

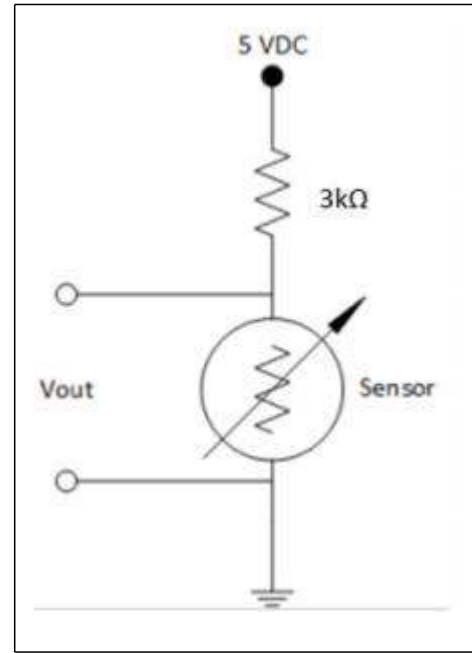

TYPICAL, 25°C CIRCUIT

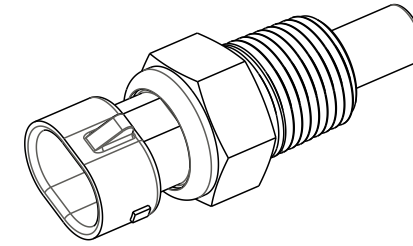
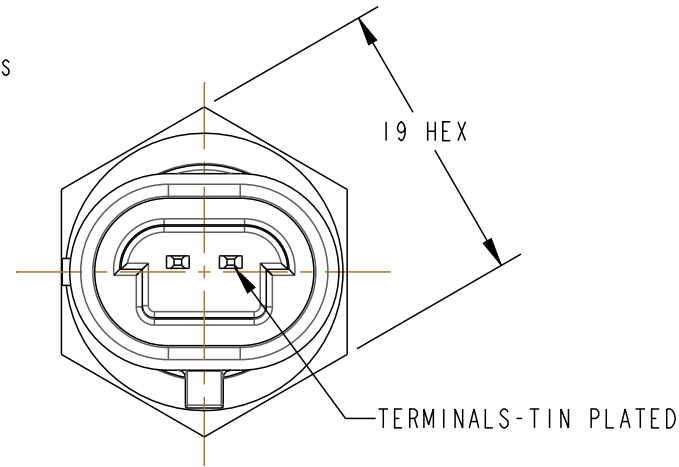

SCALE 1:1

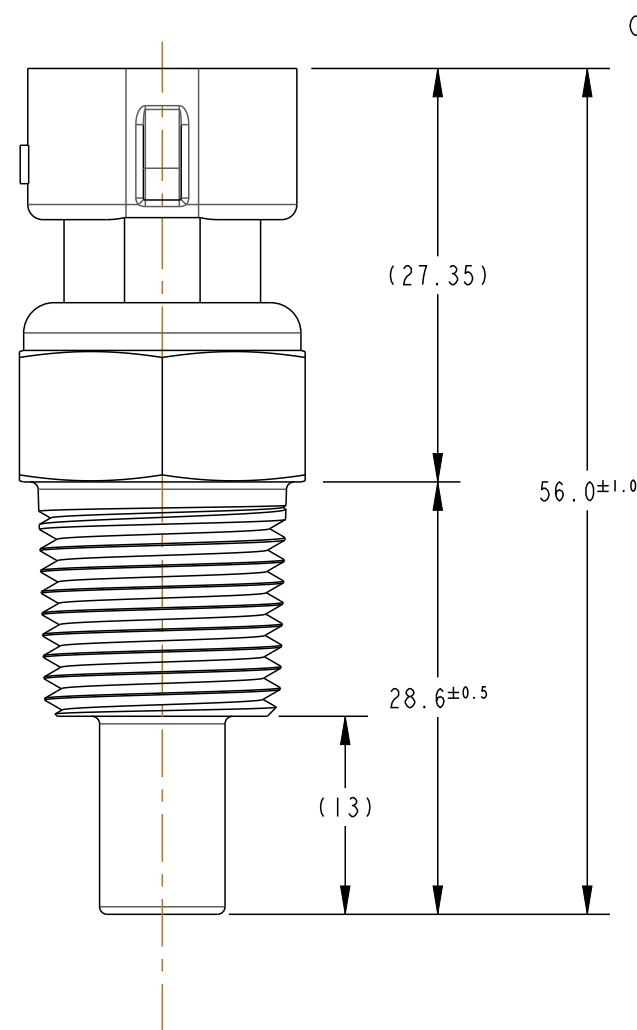

CONNECTOR: ULTEM 2300-BLACK

HOUSING: BRASS CDA 345

3/8-18 NPTF THREAD

∅8.30±0.13

Amphenol
Advanced Sensors St. Marys, PA 15857

TITLE: FLUID TEMPERATURE SENSOR

UNLESS OTHERWISE SPECIFIED DIMENSIONS ARE IN MM TOLERANCES ARE: .X ± 0.5 .XX ± 0.25	APPROVALS		DATE
	DRAWN	DAM/MED	06/04/18
ANGLES ± 2°	CHECKED	STS	06/04/18
	ENGR	JD	06/04/18
THIRD ANGLE PROJECTION	OC		
INTERPRET DRAWING IAW ASME Y14.5	MFG		
MATERIAL SEE DRAWING			
SIZE B	DWG NO. GE-2158	REV D	
SCALE 2:1	SHEET 1 OF 1		

LEGAL NOTICE - THIS DRAWING AND ANY INTELLECTUAL PROPERTY RIGHTS THERE IN ARE PROPERTY OF AMPHENOL AND NO LICENSES ARE GRANTED UNDER THOSE RIGHTS.

4

3

2

1