



**MICROCHIP**

---

**MiWi™ Protocol to Wi-Fi®  
Wireless Demo Kit  
User's Guide**

---

---

**Note the following details of the code protection feature on Microchip devices:**

- Microchip products meet the specification contained in their particular Microchip Data Sheet.
- Microchip believes that its family of products is one of the most secure families of its kind on the market today, when used in the intended manner and under normal conditions.
- There are dishonest and possibly illegal methods used to breach the code protection feature. All of these methods, to our knowledge, require using the Microchip products in a manner outside the operating specifications contained in Microchip's Data Sheets. Most likely, the person doing so is engaged in theft of intellectual property.
- Microchip is willing to work with the customer who is concerned about the integrity of their code.
- Neither Microchip nor any other semiconductor manufacturer can guarantee the security of their code. Code protection does not mean that we are guaranteeing the product as "unbreakable."

Code protection is constantly evolving. We at Microchip are committed to continuously improving the code protection features of our products. Attempts to break Microchip's code protection feature may be a violation of the Digital Millennium Copyright Act. If such acts allow unauthorized access to your software or other copyrighted work, you may have a right to sue for relief under that Act.

---

Information contained in this publication regarding device applications and the like is provided only for your convenience and may be superseded by updates. It is your responsibility to ensure that your application meets with your specifications. MICROCHIP MAKES NO REPRESENTATIONS OR WARRANTIES OF ANY KIND WHETHER EXPRESS OR IMPLIED, WRITTEN OR ORAL, STATUTORY OR OTHERWISE, RELATED TO THE INFORMATION, INCLUDING BUT NOT LIMITED TO ITS CONDITION, QUALITY, PERFORMANCE, MERCHANTABILITY OR FITNESS FOR PURPOSE. Microchip disclaims all liability arising from this information and its use. Use of Microchip devices in life support and/or safety applications is entirely at the buyer's risk, and the buyer agrees to defend, indemnify and hold harmless Microchip from any and all damages, claims, suits, or expenses resulting from such use. No licenses are conveyed, implicitly or otherwise, under any Microchip intellectual property rights.

### Trademarks

The Microchip name and logo, the Microchip logo, dsPIC, FlashFlex, KEELOQ, KEELOQ logo, MPLAB, PIC, PICmicro, PICSTART, PIC<sup>32</sup> logo, rPIC, SST, SST Logo, SuperFlash and UNI/O are registered trademarks of Microchip Technology Incorporated in the U.S.A. and other countries.

FilterLab, Hampshire, HI-TECH C, Linear Active Thermistor, MTP, SEEVAL and The Embedded Control Solutions Company are registered trademarks of Microchip Technology Incorporated in the U.S.A.

Silicon Storage Technology is a registered trademark of Microchip Technology Inc. in other countries.

Analog-for-the-Digital Age, Application Maestro, BodyCom, chipKIT, chipKIT logo, CodeGuard, dsPICDEM, dsPICDEM.net, dsPICworks, dsSPEAK, ECAN, ECONOMONITOR, FanSense, HI-TIDE, In-Circuit Serial Programming, ICSP, Mindi, MiWi, MPASM, MPF, MPLAB Certified logo, MPLIB, MPLINK, mTouch, Omniscient Code Generation, PICC, PICC-18, PICDEM, PICDEM.net, PICkit, PICtail, REAL ICE, rLAB, Select Mode, SQI, Serial Quad I/O, Total Endurance, TSHARC, UniWinDriver, WiperLock, ZENA and Z-Scale are trademarks of Microchip Technology Incorporated in the U.S.A. and other countries.

SQTP is a service mark of Microchip Technology Incorporated in the U.S.A.

GestIC and ULPP are registered trademarks of Microchip Technology Germany II GmbH & Co. KG, a subsidiary of Microchip Technology Inc., in other countries.

All other trademarks mentioned herein are property of their respective companies.

© 2013, Microchip Technology Incorporated, Printed in the U.S.A., All Rights Reserved.

 Printed on recycled paper.

ISBN: 978-1-62077-323-9

**QUALITY MANAGEMENT SYSTEM  
CERTIFIED BY DNV  
= ISO/TS 16949 =**

*Microchip received ISO/TS-16949:2009 certification for its worldwide headquarters, design and wafer fabrication facilities in Chandler and Tempe, Arizona; Gresham, Oregon and design centers in California and India. The Company's quality system processes and procedures are for its PIC<sup>®</sup> MCUs and dsPIC<sup>®</sup> DSCs, KEELOQ<sup>®</sup> code hopping devices, Serial EEPROMs, microperipherals, nonvolatile memory and analog products. In addition, Microchip's quality system for the design and manufacture of development systems is ISO 9001:2000 certified.*

**Object of Declaration: MiWi™ Protocol to Wi-Fi® Wireless Demo Kit**

EU Declaration of Conformity

This declaration of conformity is issued by the manufacturer.

The development/evaluation tool is designed to be used for research and development in a laboratory environment. This development/evaluation tool is not a Finished Appliance, nor is it intended for incorporation into Finished Appliances that are made commercially available as single functional units to end users under EU EMC Directive 2004/108/EC and as supported by the European Commission's Guide for the EMC Directive 2004/108/EC (8<sup>th</sup> February 2010).

This development/evaluation tool complies with EU RoHS2 Directive 2011/65/EU.

For information regarding the exclusive, limited warranties applicable to Microchip products, please see Microchip's standard terms and conditions of sale, which are printed on our sales documentation and available at [www.microchip.com](http://www.microchip.com).

Signed for and on behalf of Microchip Technology Inc. at Chandler, Arizona, USA



Derek Carlson  
VP Development Tools

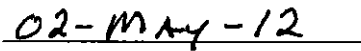

Date

# MiWi™ Protocol to Wi-Fi® Wireless Demo Kit User's Guide

---

---

NOTES:



# MIWI™ PROTOCOL TO WI-FI® WIRELESS DEMO KIT USER'S GUIDE

## Table of Contents

<b>Preface</b> .....	<b>7</b>
<b>Chapter 1. Overview</b>	
1.1 MiWi Protocol to Wi-Fi Wireless Demo Kit Contents .....	13
1.2 MiWi Protocol to Wi-Fi Wireless Demo Kit Features .....	13
<b>Chapter 2. Hardware</b>	
2.1 Wireless Evaluation Board Layout and Features .....	15
2.2 MiWi Demo Board Layout and Features .....	17
2.3 Hardware Details .....	19
<b>Chapter 3. Getting Started</b>	
3.1 Hardware Requirements .....	23
3.2 Setting up the Demo .....	24
3.3 Demonstration .....	25
3.4 Firmware Update .....	35
<b>Chapter 4. Self-Test Procedure</b>	
4.1 Self-Test Procedure .....	37
<b>Appendix A. Wireless Evaluation Board Schematic</b>	
A.1 Introduction .....	39
A.2 Wireless Evaluation Board Schematics .....	39
A.3 Wireless Evaluation Board PCB Layout .....	42
A.4 Wireless Evaluation Board Bill of Materials .....	43
<b>Appendix B. MiWi Demo Board Schematic</b>	
B.1 Introduction .....	47
B.2 MiWi Demo Board Schematics .....	47
B.3 MiWi Demo Board PCB Layout .....	51
B.4 MiWi Demo Board Bill of Materials (BOM) .....	57
<b>Index</b> .....	<b>59</b>
<b>Worldwide Sales and Service</b> .....	<b>60</b>

# MiWi™ Protocol to Wi-Fi® Wireless Demo Kit User's Guide

---

---

NOTES:



# MiWi™ PROTOCOL TO Wi-Fi® WIRELESS DEMO KIT USER'S GUIDE

## Preface

### NOTICE TO CUSTOMERS

All documentation becomes dated, and this manual is no exception. Microchip tools and documentation are constantly evolving to meet customer needs, so some actual dialogs and/or tool descriptions may differ from those in this document. Please refer to our web site ([www.microchip.com](http://www.microchip.com)) to obtain the latest documentation available.

Documents are identified with a “DS” number. This number is located on the bottom of each page, in front of the page number. The numbering convention for the DS number is “DSXXXXXXXXA”, where “XXXXXXXX” is the document number and “A” is the revision level of the document.

For the most up-to-date information on development tools, see the MPLAB® X IDE online help. Select the Help menu, and then Topics to open a list of available online help files.

### INTRODUCTION

This chapter contains general information that will be useful to know before using the MiWi™ Protocol to Wi-Fi® Wireless Demo Kit User's Guide. Items discussed in this chapter include:

- [Document Layout](#)
- [Conventions Used in this Guide](#)
- [Warranty Registration](#)
- [Recommended Reading](#)
- [The Microchip Web Site](#)
- [Development Systems Customer Change Notification Service](#)
- [Customer Support](#)
- [Document Revision History](#)

### DOCUMENT LAYOUT

This document describes how to use the MiWi Protocol to Wi-Fi Wireless Demo Kit to evaluate and experiment the Microchip Wireless Solutions. The document layout is as follows:

- **Chapter 1. “Overview”** – This chapter describes the MiWi™ Protocol to Wi-Fi® Wireless Demo Kit contents.
- **Chapter 2. “Hardware”** – This chapter details the hardware information of the Wireless Evaluation Board and MiWi Demo Board.
- **Chapter 3. “Getting Started”** – This chapter describes what you need to know to start using the MiWi Protocol to Wi-Fi Wireless Demo Kit.
- **Chapter 4. “Self-Test Procedure”** – This chapter describes the self test procedure that can be used to check the sanity of the Wireless Evaluation Board and MiWi Demo Board.

# MiWi™ Protocol to Wi-Fi® Wireless Demo Kit User's Guide

- **Appendix A. “Wireless Evaluation Board Schematic”** – This appendix illustrates the PCB layout and BOM for Wireless Evaluation Board. It also includes complete Wireless Evaluation Board schematics.
- **Appendix B. “MiWi™ Demo Board Schematic”** – This appendix illustrates the PCB layout and BOM for MiWi Demo Board. It also includes complete MiWi Demo Board schematics.

## CONVENTIONS USED IN THIS GUIDE

This manual uses the following documentation conventions:

### DOCUMENTATION CONVENTIONS

Description	Represents	Examples
<b>Arial font:</b>		
Italic characters	Referenced books	<i>MPLAB® IDE User's Guide</i>
	Emphasized text	...is the <i>only</i> compiler...
Initial caps	A window	the Output window
	A dialog	the Settings dialog
	A menu selection	select Enable Programmer
Quotes	A field name in a window or dialog	“Save project before build”
Underlined, italic text with right angle bracket	A menu path	<u><i>File&gt;Save</i></u>
Bold characters	A dialog button	Click <b>OK</b>
	A tab	Click the <b>Power</b> tab
Text in angle brackets < >	A key on the keyboard	Press <Enter>, <F1>
Plain Courier New	Sample source code	#define START
	Filenames	autoexec.bat
	File paths	c:\mcc18\h
	Keywords	_asm, _endasm, static
	Command-line options	-Opa+, -Opa-
	Bit values	0, 1
	Constants	0xFF, 'A'
<i>Italic Courier New</i>	A variable argument	<i>file.o</i> , where <i>file</i> can be any valid filename
Square brackets [ ]	Optional arguments	mcc18 [options] <i>file</i> [options]
Curly brackets and pipe character: {   }	Choice of mutually exclusive arguments; an OR selection	errorlevel {0 1}
Ellipses...	Replaces repeated text	var_name [, var_name...]
	Represents code supplied by user	void main (void) { ... }
Notes	A Note presents information that we want to re-emphasize, either to help you avoid a common pitfall or to make you aware of operating differences between some device family members. A Note can be in a box, or when used in a table or figure, it is located at the bottom of the table or figure.	<b>Note:</b> This is a standard note box.
		<b>CAUTION</b>
		<b>This is a caution note.</b>
		<b>Note 1:</b> This is a note used in a table.



## WARRANTY REGISTRATION

Please complete the enclosed Warranty Registration Card and mail it promptly. Sending in the Warranty Registration Card entitles you to receive new product updates. Interim software releases are available at the Microchip web site.

## RECOMMENDED READING

This user's guide describes how to use the MiWi Protocol to Wi-Fi Wireless Demo Kit. The following Microchip documents are available from the Microchip web site ([www.microchip.com](http://www.microchip.com)), and are recommended as supplemental reference resources:

- **PIC32MX5XX/6XX/7XX Family Data Sheet (DS60001156)**  
Refer to this document for detailed information on PIC32 devices. References information found in this data sheet include: device memory maps, device pinout and packaging details, device electrical specifications, and list of peripherals included on the devices.
- **PIC18F46J50 Data Sheet (DS39931)**  
Refer to this document for detailed information on PIC18 device operation. References information found in this data sheet include: device memory maps, device pinout and packaging details, device electrical specifications, and list of peripherals included on the devices.
- **MRF24WG0MA/MB Data Sheet 2.4 GHz IEEE 802.11b/g™ (DS70686)**  
Refer to this document for more information on the features and specifications of IEEE 802.11b/g MRF24WG0MA/MB transceiver.
- **MRF24J40MA 2.4 GHz IEEE Std. 802.15.4™ RF Transceiver Module (DS70329)**  
Refer to this document for more information on the features and specification of IEEE 802.15.4 MRF24J40MA 2.4GHz RF transceiver.
- **2K SPI Bus Serial EEPROMs with EUI-48™ or EUI-64™ Node Identity (DS20002123)**  
Refer to this document for more information about how to use EUI-48™ Serial EEPROM.
- **25AA256/25LC256 256K SPI Bus Serial EEPROM (DS21822)**  
Refer to this document for more information about how to use 25AA256/25LC256 SPI Serial EEPROM.
- **4 Mbit SPI Serial Flash SST25VF040B Data Sheet (DS25051)**  
Refer to this document for more information about how to use serial Flash that is on the Wireless Evaluation Board.
- **1 Mbit SPI Serial Flash SST25VF010A Data Sheet (S725081)**  
Refer to this document for more information about how to use serial Flash that is on the MiWi Demo Board.
- **MCP9700/9700A MCP9701/9701A - Low Power Linear Active Thermistor® ICs (DS21942)**  
Refer to this document for more information about how to use MCP9700/01 temperature sensor.
- **USB 2.0 to UART Protocol Converter with GPIO MCP2200 Data Sheet (DS22228)**  
Refer to this document for more information about how to use MCP2200 as serial port.

## THE MICROCHIP WEB SITE

Microchip provides online support through our web site at [www.microchip.com](http://www.microchip.com). This web site is used as a means to make files and information easily available to customers. Accessible by using your favorite Internet browser, the web site contains the following information:

- **Product Support** – Data sheets and errata, application notes and sample programs, design resources, user's guides and hardware support documents, latest software releases and archived software
- **General Technical Support** – Frequently Asked Questions (FAQs), technical support requests, online discussion groups, Microchip consultant program member listing
- **Business of Microchip** – Product selector and ordering guides, latest Microchip press releases, listing of seminars and events, listings of Microchip sales offices, distributors and factory representatives.

## DEVELOPMENT SYSTEMS CUSTOMER CHANGE NOTIFICATION SERVICE

Microchip's customer notification service helps keep customers current on Microchip products. Subscribers will receive e-mail notification whenever there are changes, updates, revisions or errata related to a specified product family or development tool of interest.

To register, access the Microchip web site at <http://www.microchip.com>, click **Customer Change Notification** and follow the registration instructions.

The Development Systems product group categories are:

- **Compilers** – The latest information on Microchip C compilers and other language tools
- **Emulators** – The latest information on the Microchip in-circuit emulator, MPLAB REAL ICE™ In-Circuit Emulator
- **In-Circuit Debuggers** – The latest information on the Microchip in-circuit debugger, MPLAB ICD 3
- **MPLAB® X IDE** – The latest information on Microchip MPLAB X IDE, the Windows® Integrated Development Environment for development systems tools
- **Programmers** – The latest information on Microchip programmers including the PICkit™ 3 development programmer

## CUSTOMER SUPPORT

Users of Microchip products can receive assistance through several channels:

- Distributor or Representative
- Local Sales Office
- Field Application Engineer (FAE)
- Technical Support

Customers should contact their distributor, representative or FAE for support. Local sales offices are also available to help customers. A listing of sales offices and locations is included in the back of this document.

Technical support is available through our web site at: <http://support.microchip.com>

## DOCUMENT REVISION HISTORY

### **Revision A (July 2013)**

This is the initial release of the document

# MiWi™ Protocol to Wi-Fi® Wireless Demo Kit User's Guide

---

---

NOTES:



# MiWi™ PROTOCOL TO Wi-Fi® WIRELESS DEMO KIT USER'S GUIDE

## Chapter 1. Overview

This chapter introduces the MiWi™ Protocol to Wi-Fi® Wireless Demo Kit features. Topics included in this chapter are:

- [MiWi Protocol to Wi-Fi Wireless Demo Kit Contents](#)
- [MiWi Protocol to Wi-Fi Wireless Demo Kit Features](#)

### 1.1 MiWi PROTOCOL TO Wi-Fi WIRELESS DEMO KIT CONTENTS

The MiWi Protocol to Wi-Fi Wireless Demo Kit contains the following items:

- One Wireless Evaluation Board with a PIC32MX695F512H microcontroller, and MRF24WG0MA and MRF24J40MA transceivers. The Wireless Evaluation Board acts as a gateway device (bridge) between the MiWi™ and Wi-Fi® networks
- Two MiWi Demo Boards with a PIC18F46J50 XLP microcontroller and an MRF24J40MA transceiver to create a MiWi network
- One mini-B USB cable to supply power to the Wireless Evaluation Board
- Four AAA batteries to power-up the MiWi Demo Boards
- 6-pin In-Circuit Serial Programming™ (ICSP™) adaptor to use with MPLAB ICD 3/MPLAB REAL ICE™ In-Circuit Emulator/PICkit™ 3 programmer for programming the Wireless Evaluation Board and MiWi Demo Board

**Note:** The Wireless Evaluation Board requires approximately 400 mA power at 3.3V and it is not always guaranteed with a USB power source. Use a 9V external power supply if you encounter this issue.

### 1.2 MiWi PROTOCOL TO Wi-Fi WIRELESS DEMO KIT FEATURES

The MiWi Protocol to Wi-Fi Wireless Demo Kit enables developers to extend a simple MiWi network to an internet web server/Cloud for gathering information and controlling the network. The Wireless Evaluation Board contains the MiWi 2.4 GHz MRF24J40MA and the Wi-Fi 2.4 GHz MRF24WG0MA transceivers. The information that flows between the MiWi nodes and the gateway device controls the nature of the application with which the customer intends to experiment.

The MiWi Protocol to Wi-Fi Wireless Demo Kit is preprogrammed with a wireless demo program, which demonstrates the idea of commissioning and controlling the MiWi P2P network from the web browser.

# MiWi™ Protocol to Wi-Fi® Wireless Demo Kit User's Guide

---

---

NOTES:



---

---

## Chapter 2. Hardware

---

---

This chapter describes the board layout and features of the Wireless Evaluation Board and the MiWi™ Demo Board. Topics included in this chapter are:

- [Wireless Evaluation Board Layout and Features](#)
- [MiWi Demo Board Layout and Features](#)
- [Hardware Details](#)

### 2.1 WIRELESS EVALUATION BOARD LAYOUT AND FEATURES

This section describes the Wireless Evaluation Board hardware and its key components. The following key features are indicated in [Figure 2-1](#) and [Figure 2-2](#):

1. PIC32MX695F512L 32-bit PIC® Microcontroller
2. IEEE 802.15.4 MRF24J40MA transceiver
3. 8 MHz on-board crystal
4. Three status indicators, LEDs: LED0 (green), LED1 (yellow), and LED2 (red)
5. Three push buttons for user input: SW0, SW1, and SW2
6. 2x16 LCD
7. MCP9700 temperature sensor (TEMP/AN10)
8. 256K SPI serial EEPROM
9. 4 Mb SPI serial Flash memory
10. 32 kHz sleep crystal
11. +9V DC power supply connector
12. PICtail™ Expansion Interface
13. PICKIT 2 style programming header
14. Analog potentiometer (POT/AN10)
15. MRF24WG0MA 2.4 GHz 802.11g Wi-Fi® transceiver
16. MCP2200 with mini-B USB

# MiWi™ Protocol to Wi-Fi® Wireless Demo Kit User's Guide

FIGURE 2-1: WIRELESS EVALUATION BOARD (FRONT VIEW)

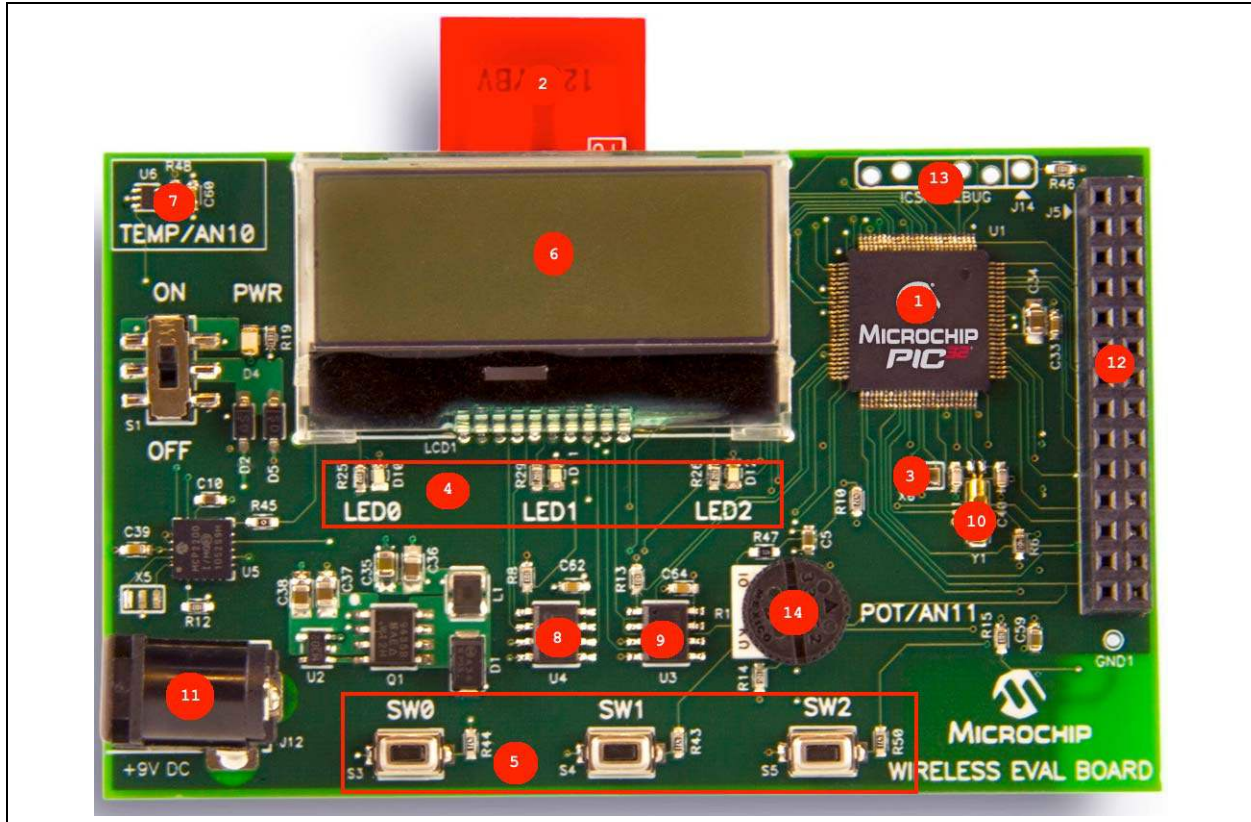
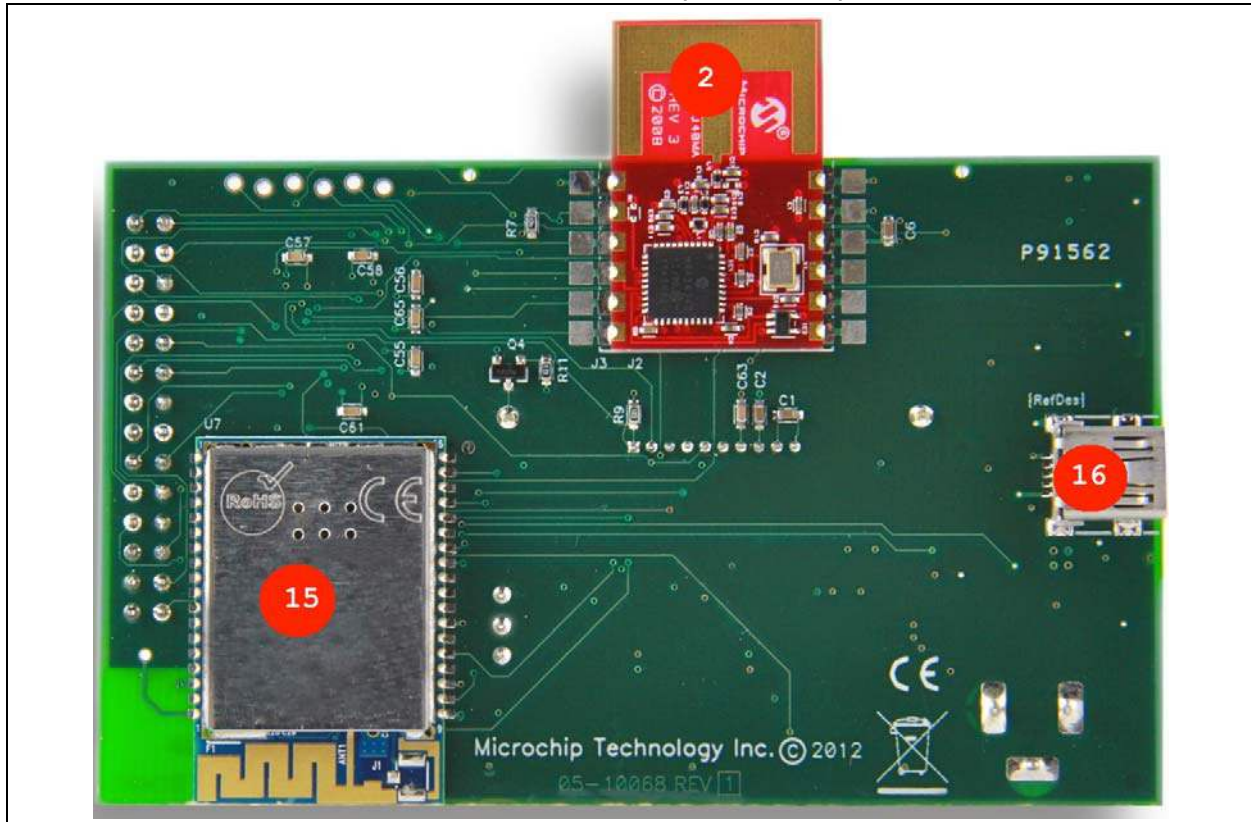

FIGURE 2-2: WIRELESS EVALUATION BOARD (REAR VIEW)





## 2.2 MiWi DEMO BOARD LAYOUT AND FEATURES

This section describes the MiWi Demo Board hardware and its key components. The following key features are indicated in [Figure 2-3](#) and [Figure 2-4](#):

1. PIC18F46J50 8-bit XLP microcontroller
2. MRF24J40MA RF transceiver module
3. +3.3V boost regulator (MCP1640)
4. Three status indicators, LEDs: LED1 (green), LED2 (yellow), and LED3 (red)
5. Two push buttons for user input: SW1 and SW2
6. 2x16 LCD
7. MCP9700 temperature sensor
8. 2K SPI EEPROM with a unique MAC address
9. 1 Mb SPI serial Flash memory
10. 32 kHz crystal for Sleep mode

**FIGURE 2-3: MiWi™ DEMO BOARD (FRONT VIEW)**

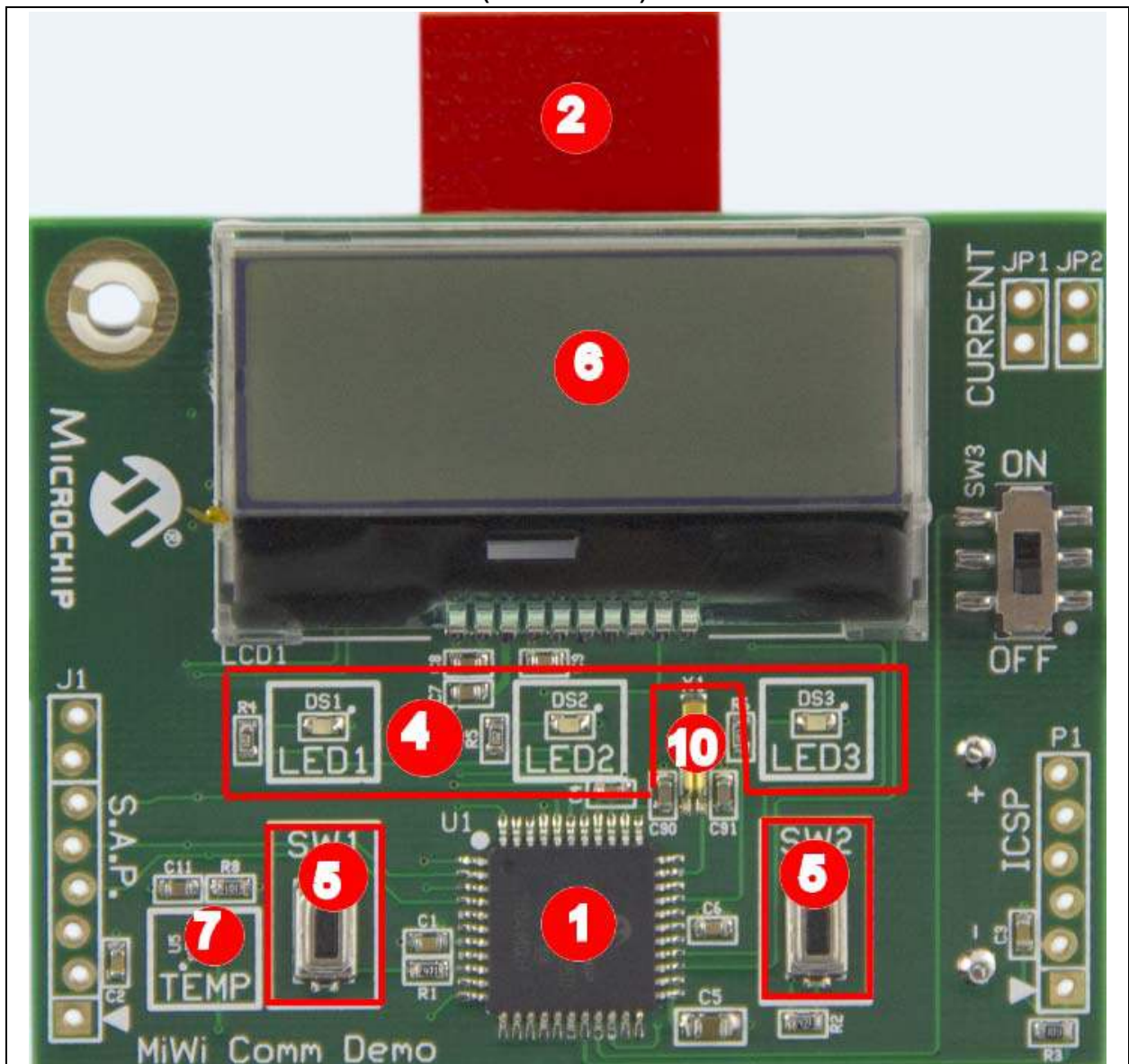
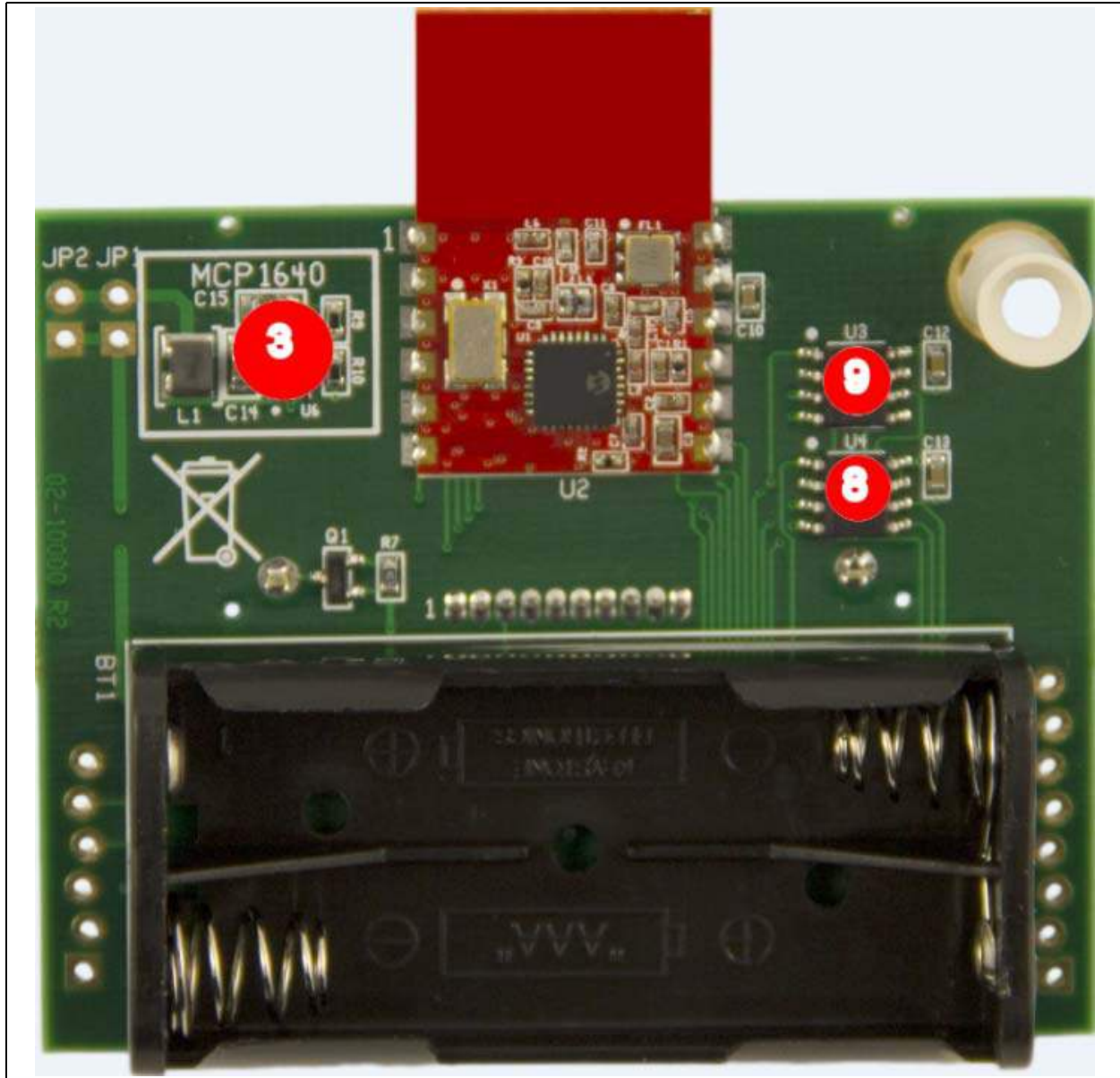

FIGURE 2-4: MiWi™ DEMO BOARD (REAR VIEW)



## 2.3 HARDWARE DETAILS

Detailed information of the hardware blocks is as follows:

### 2.3.1 PIC32MX695F512L Microcontroller on Wireless Evaluation Board

The Wireless Evaluation Board uses a PIC32 microcontroller to support a variety of applications. The larger memory size in the PIC32 enables storing the web pages on the board.

### 2.3.2 PIC18F46J50 Microcontroller on MiWi Demo Board

PIC18F46J50 is an 8-bit XLP 44-pin microcontroller with 64K program memory.

### 2.3.3 MRF24J40MA RF Transceiver Module

The Wireless Evaluation Board and the MiWi Demo Board use the IEEE 802.15.4 MRF24J40MA RF Transceiver module for creating a MiWi network. This module has a dedicated SPI and interrupt lines with the PIC MCU.

### 2.3.4 MRF24WG0MA Wi-Fi Transceiver Module

The Wireless Evaluation Board has an on-board Wi-Fi 2.4 GHz MRF24WG0MA Transceiver module. This module is used for connecting to the B/G Wi-Fi networks at home or office.

### 2.3.5 Status Indicator LEDs

#### 2.3.5.1 MiWi DEMO BOARD

To indicate the status, the MiWi Demo Board has three LEDs: LED1 (green), LED2 (yellow), and LED3 (red).

#### 2.3.5.2 WIRELESS EVALUATION BOARD

To indicate the status, the Wireless Evaluation Board has three LEDs: LED0 (green), LED1 (yellow), and LED2 (red).

## 2.3.6 Push Buttons

### 2.3.6.1 WIRELESS EVALUATION BOARD

This board contains three push buttons for user input: SW0, SW1, and SW2.

### 2.3.6.2 MiWi DEMO BOARD

This board contains two push buttons, SW1 and SW2, which are assigned to the individual interrupt lines of the microcontroller. The user software must enable PORTB pull-ups of the microcontroller before evaluating the state of the push button.

[Example 2-1](#) provides a possible solution to evaluate the state of SW1 push button.

#### EXAMPLE 2-1: CODE EXAMPLE FOR EVALUATING THE STATE OF SW1

```
// Initialize RB1 - SW1
TRISBbits.TRISB2 = 1;// RB1 is an input
ANCON1 = ANCON1 | 0x04;// RB1 is a digital pin
/*
User Code
*/
//Evaluating RB1
INTCON2bits.RBPU = 0;// Enable PORT B pull-ups for switches
If (PORTBbits.RB1 = 0 )// RB1 pushed
{
/*
RB1/SW1 push button code
*/
}
INTCON2bits.RBPU = 1;//PORTB pull-ups disabled
```

## 2.3.7 Liquid Crystal Display (LCD)

The LCD supports power-saving modes. The LCD has a backlight display, which can be turned ON or OFF based on power consumption, and it supports 32 characters in two lines (16 characters in each line).

On the Wireless Evaluation Board, the SPI is shared between the LCD and serial Flash memory. On the MiWi Demo Board, the SPI is shared between the EEPROM, Flash, and LCD.

## 2.3.8 Temperature Sensor

The Temperature Sensor (MCP9700A) is a low-power Linear Active Thermistor IC. To minimize power consumption, the sensor is powered from a port pin. On power-up, the sensor output can be measured after a minute. The internal Analog-to-Digital Converter (ADC) of the microcontroller can be used to measure the temperature value.

## 2.3.9 Serial EEPROM with MAC Address on the MiWi Demo Board

The Serial EEPROM is a Microchip low-power 256K SPI Bus Serial EEPROM. It uses the shared SPI with the SPI serial Flash and the LCD.

## **2.3.10 SPI Serial Flash**

### 2.3.10.1 WIRELESS EVALUATION BOARD

This board features a 4 Mb SPI serial Flash for storing and retrieving network information. The same SPI (SPI3) is shared between the LCD and the serial Flash.

### 2.3.10.2 MiWi DEMO BOARD

This board features a 1 Mb SPI serial Flash for storing and retrieving network or any application specific information. The SPI serial Flash and the Serial EEPROM share the SPI bus, and each has its own active low chip select.

## **2.3.11 Power Supply**

### 2.3.11.1 WIRELESS EVALUATION BOARD

This board can be powered up using a mini-B USB cable or a +9V DC power supply.

### 2.3.11.2 MiWi DEMO BOARD

This board uses two AAA batteries for its power supply. Current consumption on the entire board can be measured at JP1 and JP2 without disturbing the board.

## **2.3.12 +3.3V Boost Regulator on MiWi Demo Board**

The MCP1640 is a compact, high efficiency boost regulator. It ensures that the voltage requirements for the RF transceivers are met throughout the life span of the battery.

## **2.3.13 PICtail™ Board Expansion Interface**

Developers can use the PICtail Board Expansion Interface and plug-in PICtail Daughter Boards to increase the hardware capacities.

## **2.3.14 MCP2200 with mini-B USB**

For debugging, the on-board MCP2200 to USB can be used as a UART.

# MiWi™ Protocol to Wi-Fi® Wireless Demo Kit User's Guide

---

---

NOTES:



---

## Chapter 3. Getting Started

---

This chapter describes how to run the preprogrammed demonstration program. The Wireless Evaluation Board contains the 2.4 GHz MiWi transceiver along with the MiWi Demo Boards, which can be used to create a three node MiWi network. Using the Wi-Fi connection, the LCD backlight on the MiWi Demo Boards can be turned ON or OFF from a web page. The source code for the demo program is available in the Microchip Library of Applications (MLA). The project folder is available at `Microchip Solutions\Combo\MiWi Protocol to Wi-Fi Gateway Demo Board\`. Source code for both the Wireless Evaluation Board and the MiWi Demo Board are available at this location.

For information on Microchip Wi-Fi products, visit the Microchip web site at <http://www.microchip.com/WiFi>, and for Microchip MiWi products visit <http://www.microchip.com/MiWi>.

The following topics are included in this chapter:

- [Hardware Requirements](#)
- [Setting up the Demo](#)
- [Demonstration](#)
- [Firmware Update](#)

### 3.1 HARDWARE REQUIREMENTS

The following hardware components are required to run the demo application:

- Wireless Evaluation Board
- MiWi Demo Board
- Mini-B USB cable or external 9V adaptor to supply power to the Wireless Evaluation Board
- Two AAA batteries for each MiWi Demo Board

## 3.2 SETTING UP THE DEMO

### 3.2.1 To Set up the Demo on the Wireless Evaluation Board

1. Connect the Wireless Evaluation Board to a PC using the mini-B USB cable.
2. To power-up the board, move the switch S1 from the OFF to the ON position.
3. Ensure the PWR LED lights are green. If the PWR LED does not turn ON, verify the power supply to the board.

**Note 1:** The Wireless Evaluation Board needs approximately 400 mA power at 3.3V. If you encounter any problem in powering the board using a USB, use a 9V external power supply.

**2:** You can skip installing device drivers for a USB if the connection is only serving as a power supply. Device drivers for the MCP2200 can be downloaded from the Microchip web site (<http://www.microchip.com/mcp2200>).

### 3.2.2 To Set up the Demo on the MiWi Demo Boards

1. Insert two AAA batteries in each MiWi Demo Board.
2. To power-up the board, move the switch SW3 from the OFF to the ON position.
3. On power-up, the following message will be displayed on the LCD screen:

“CH: 11 PANID:1111

0004A3FFFE341D67”

CH: 11 PANID:1111 indicates the current channel (CH). The default channel is 11, and the default PANID is 1111 (4-digit hex). 0004A3FFFE341D67 indicates 16-hexadecimal digits, which is the unique MAC address for the node.

**Note:** Upon powering up the node, if the channel or PAN ID is not the default, press the **SW2** push button and then press the **SW1** push button to reset the node to Commission mode on the MiWi Demo Board.



### 3.3 DEMONSTRATION

The following topics are included in this section:

- [Connecting the Wireless Evaluation Board to a Client Device](#)
- [Setting up Rooms](#)
- [Commissioning the MiWi Node](#)
- [Controlling the MiWi Node](#)
- [Reconfiguring the Wi-Fi Network](#)

#### 3.3.1 Connecting the Wireless Evaluation Board to a Client Device

To run the demonstration, perform these actions:

1. On powering the Wireless Evaluation Board, the following message will be displayed on the LCD screen:  
“MiWi – Wi-Fi  
Gateway Demo”
2. LED0 starts blinking which indicates the MiWi network and the Wi-Fi network are up and running.
3. To connect a laptop or a smart device to the wireless network of the Wireless Evaluation Board, perform a scan operation from the PC. The default SSID of the Wireless Evaluation Board is MCHP\_G\_ xxxx, where xxxx is the last four digits of the Wi-Fi transceiver's unique MAC address, as shown in [Figure 3-1](#). On power-up, the SSID of the Wireless Evaluation Board is also displayed on the LCD of the board.

**FIGURE 3-1: SCAN RESULTS**



4. Connect a client device, such as a PC, laptop or smart device to the MCHP\_G\_xxxx network, see [Figure 3-2](#).

**FIGURE 3-2: ESTABLISHING THE CONNECTION**



5. Click **Connect**. The "Connected" message appears next to the MCHP\_G\_xxxx network, see [Figure 3-3](#).

**FIGURE 3-3: CONNECTION SUCCESS**

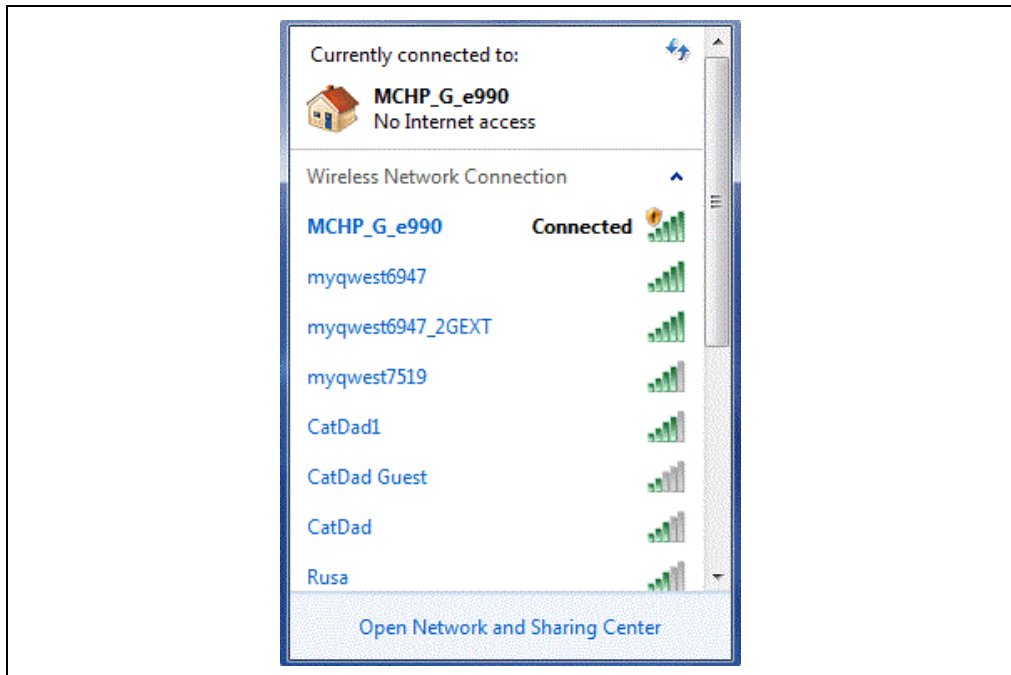

6. After connecting the client device, open a standard web browser such as Google Chrome, Mozilla Firefox, Internet Explorer or Safari and type in the IP address of the Wireless Evaluation Board. The default IP address is 192.168.1.3, see [Figure 3-4](#).

**Note:** The current IP address of the gateway device will be updated on the LCD screen.

**FIGURE 3-4: OPEN WEB BROWSER**

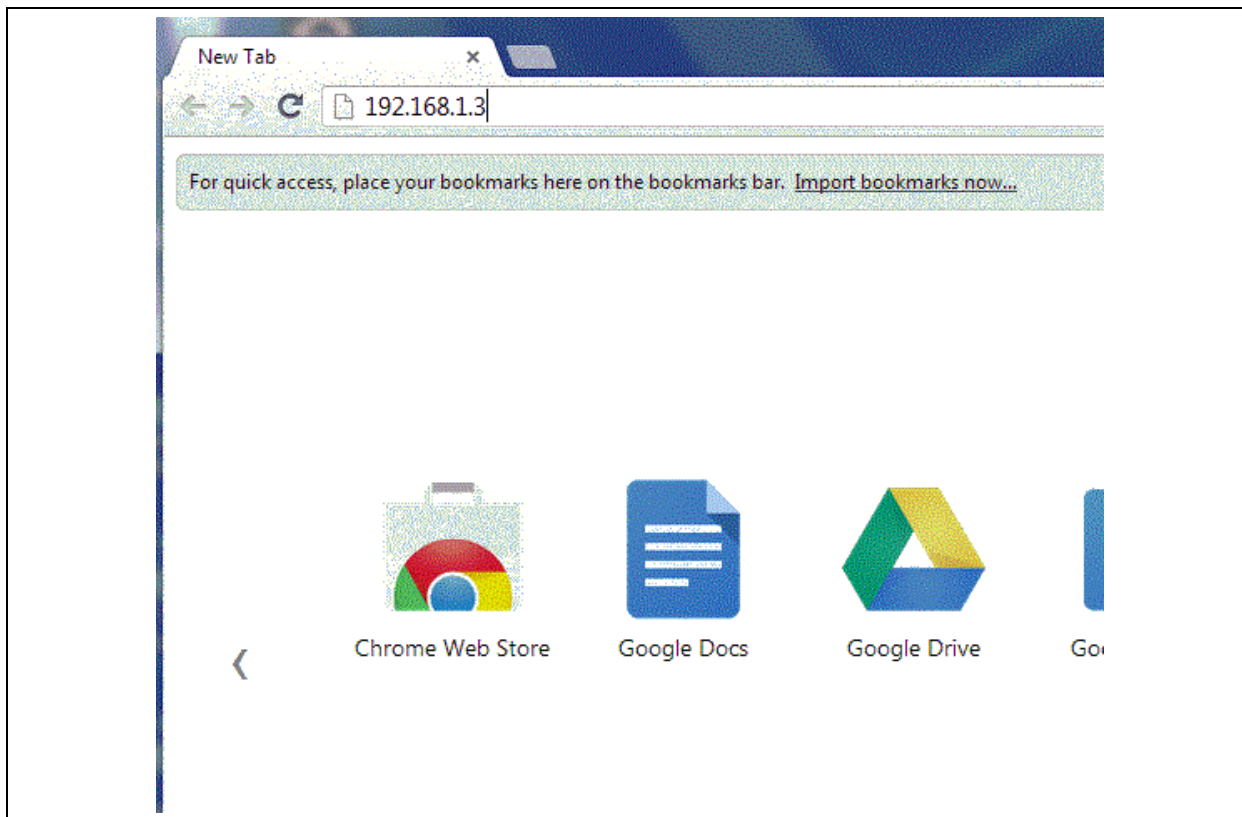

7. A web page with a “Welcome!” message will be displayed in the web browser, see [Figure 3-5](#).

FIGURE 3-5: INDEX PAGE

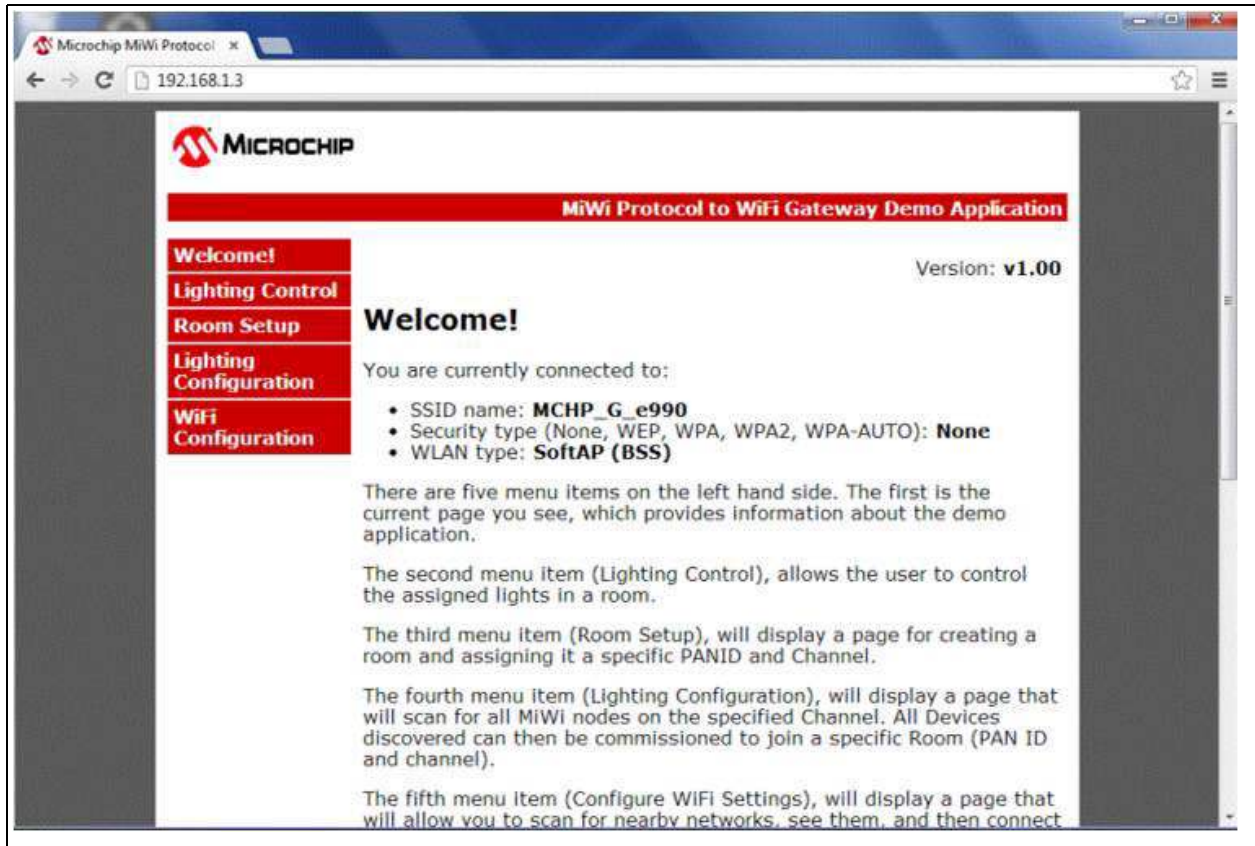

8. The web page contains five tabs, which enable the user to assign a room to each node and to turn the lights ON or OFF in each room.

### 3.3.2 Setting up Rooms

1. Click the **Room Setup** tab to display the information.
2. From **Select Channel**, select the Channel, enter the Room Name and PAN ID, and then click **Add Room**.

Optional: To erase room information, press the **SW0** push button on the board. Press the **SW0** push button a second time to confirm the erasure.

**Note:** All room information will be stored in the EEPROM of the gateway device; therefore, powering off the device does not erase room information.

3. Add two rooms, see in [Figure 3-6](#).

FIGURE 3-6: CREATING ROOMS

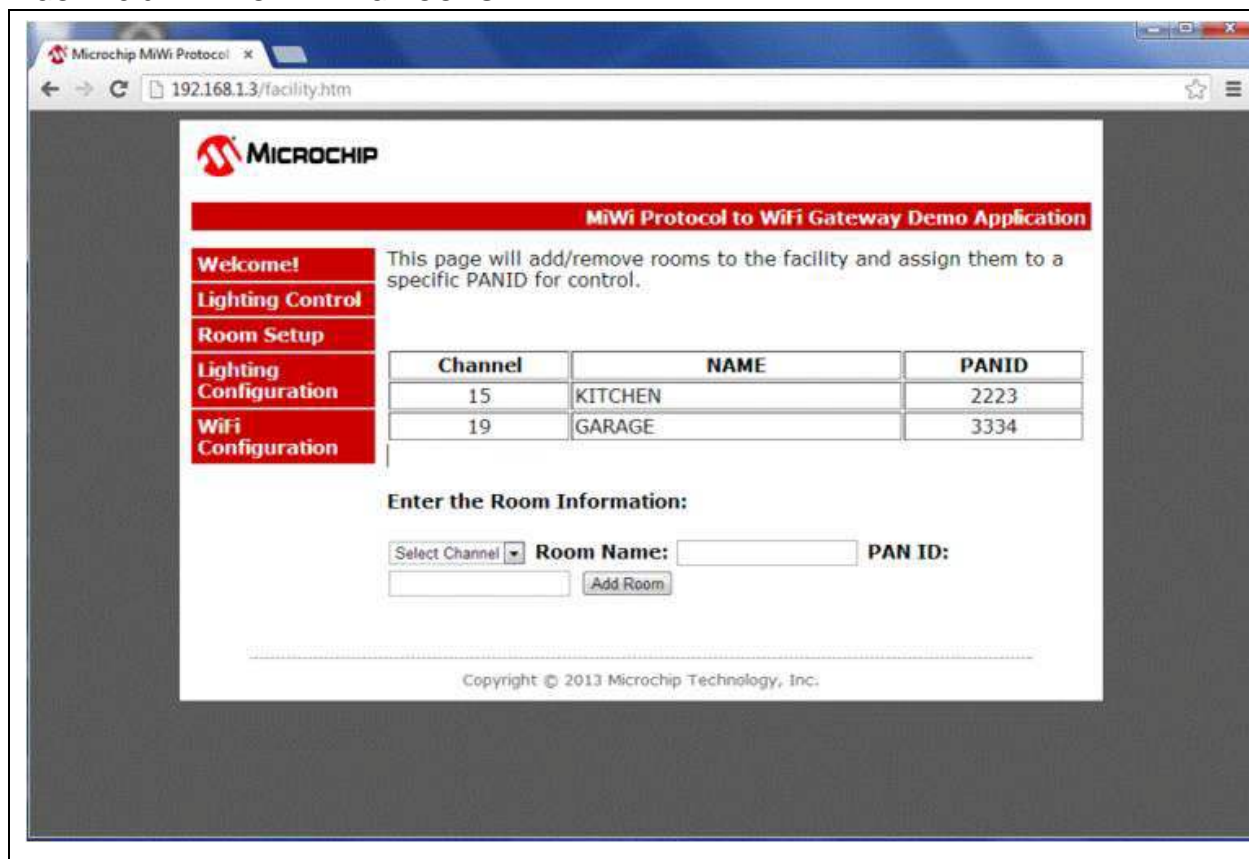

### 3.3.3 Commissioning the MiWi Node

1. Click the **Lighting Configuration** tab. This web page will scan for MiWi nodes and display the node information. Also, from this web page all MiWi Demo Boards that are in Commission mode can be assigned a PAN ID and a Channel, see [Figure 3-7](#).

FIGURE 3-7: SCANNING FOR MIWI™ NODES

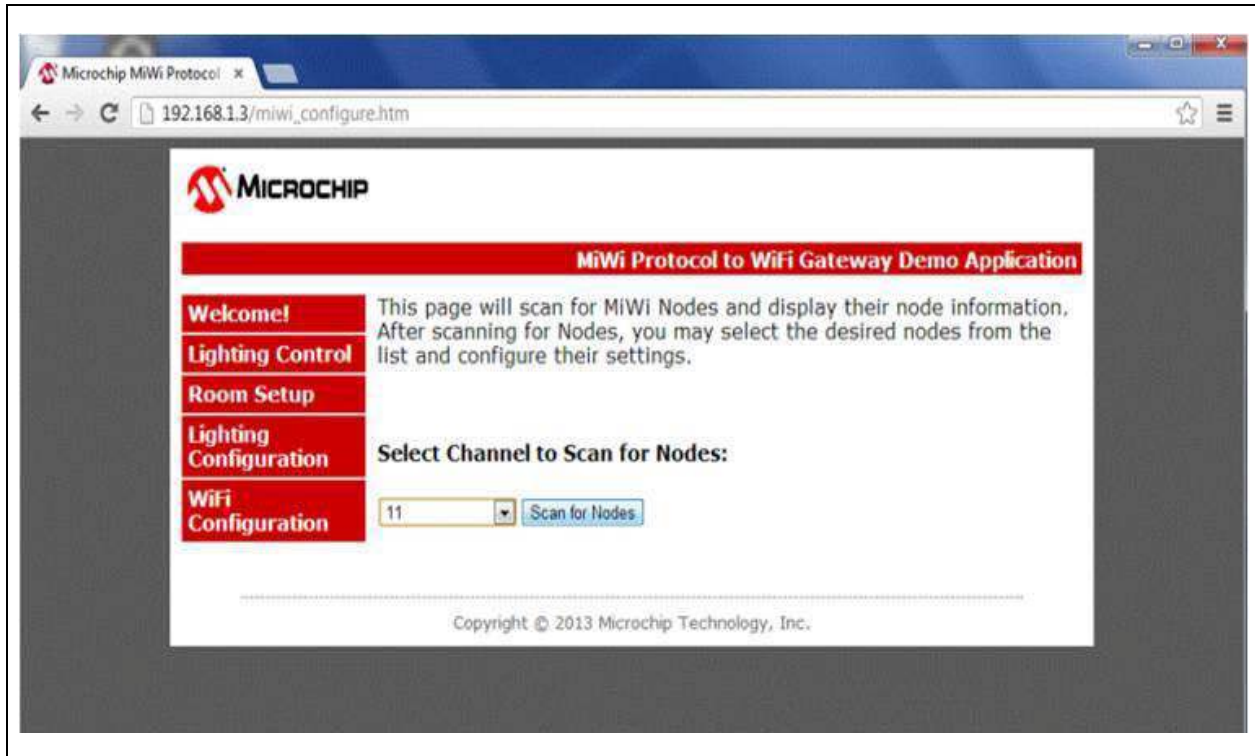

2. Scan for all the nodes in channel 11, which is the default channel for nodes in Commission mode. The scan results display two MiWi Demo Boards that are in Commission mode, see [Figure 3-8](#).

**Note:** The MiWi nodes must be in Commission mode for the gateway device to configure the node to a room. If the MiWi node is not in Commission mode, press the **SW2** push button and then press the **SW1** push button on the MiWi Demo Board.

**FIGURE 3-8: CONFIGURING NODE TO A ROOM – COMMISSIONING**

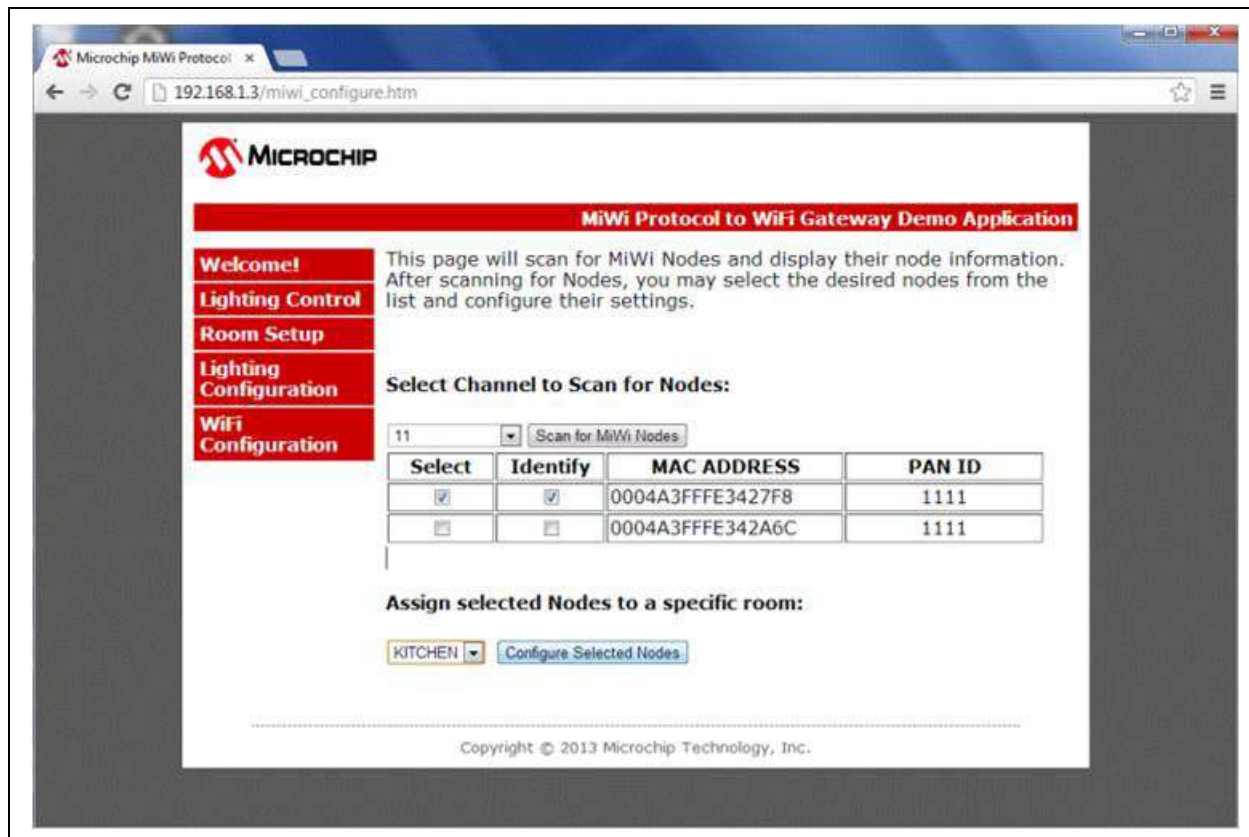

3. On the scan results web page, perform these actions:
  - a) Select the check box under **Select** to configure the node.
  - b) Select the check box under **Identify** to see the LEDs flashing on the corresponding MiWi Demo Board.
4. From the drop-down menu, select the room and then click **Configure Selected Nodes** to commission the nodes.
5. The LCD on the MiWi Demo Board reflects the change. The Channel information (which is displayed on the LCD) and PAN ID will reflect new values based on the selected room's configuration values.
6. Repeat the commissioning process for other MiWi Demo Boards.

## 3.3.4 Controlling the MiWi Node

1. Click the **Lighting Control** tab after all nodes are commissioned, see [Figure 3-9](#).

**FIGURE 3-9: CONTROLLING LIGHTS IN EACH ROOM**

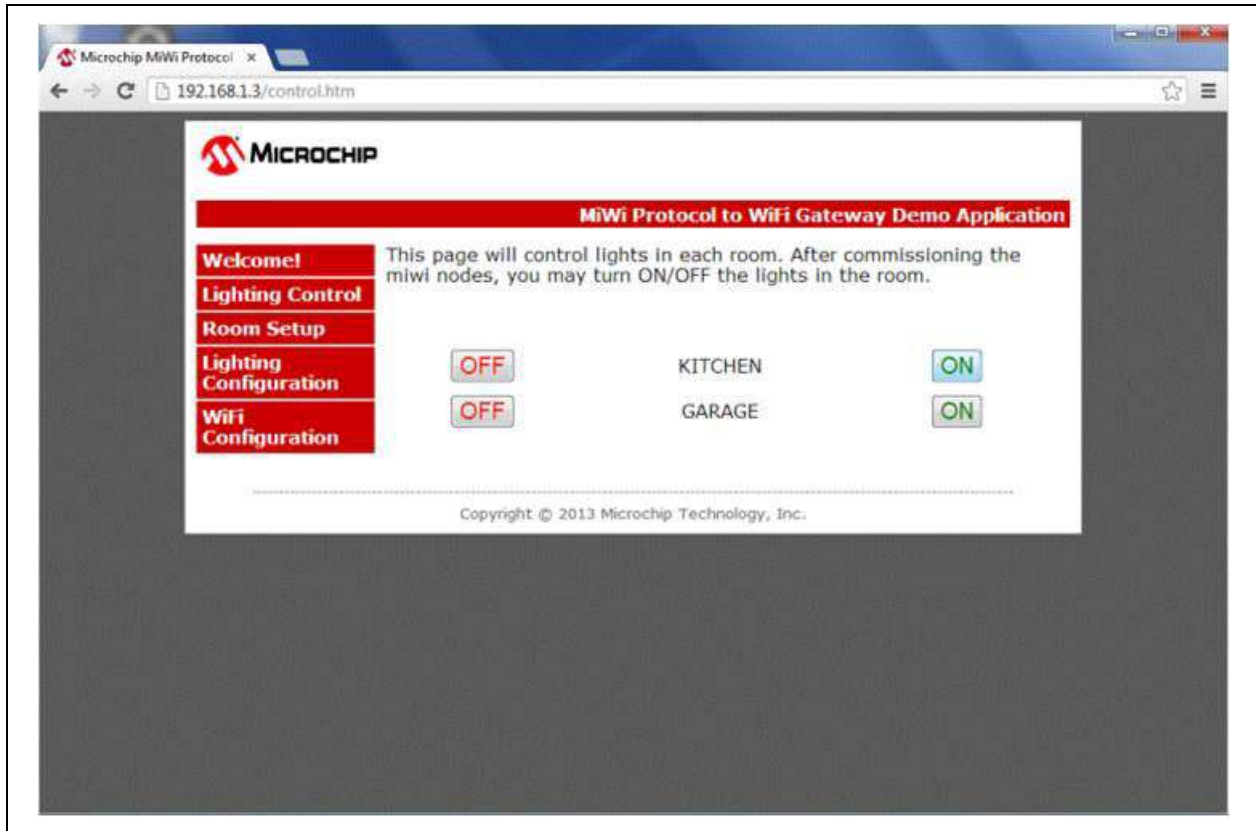

2. To turn the LCD backlights in each room on or off, click the **ON** or **OFF** buttons.



### 3.3.5 Reconfiguring the Wi-Fi Network

1. The default mode for the Wi-Fi network is Soft AP mode, which enables the user to connect a client device to the hardware and configure it. The user can reconfigure the Wi-Fi network to a home or office network.
2. Click *Wi-Fi Configuration>Display Scan Results*, see [Figure 3-10](#).

**Note:** Clicking **Display Scan Results** results in a scan operation if the current configuration is set to Ad Hoc mode or Infrastructure mode. The prescan results are used only during Soft AP mode.

FIGURE 3-10: CONFIGURE Wi-Fi® TO A HOME NETWORK

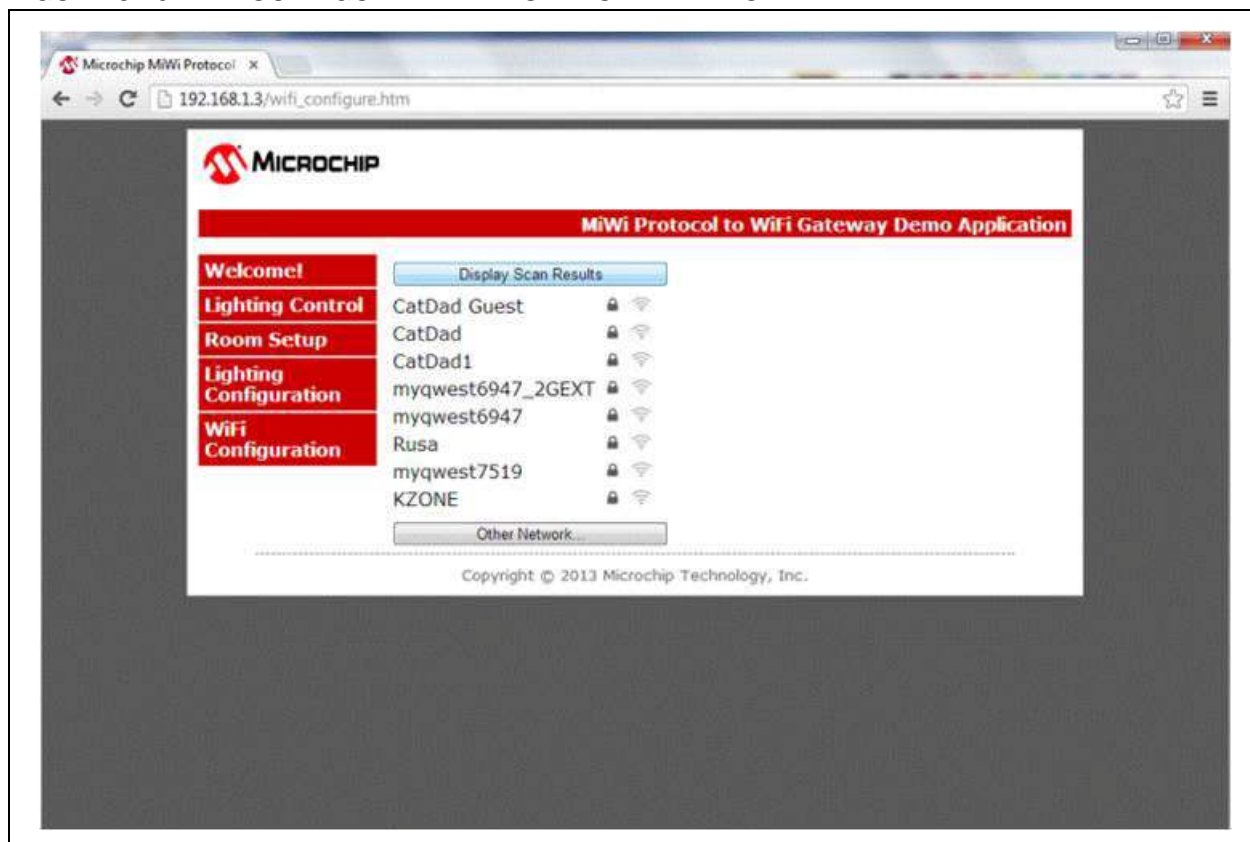

- From the list of available networks, select a network to reconfigure. Once the reconfigure process starts, the Reconnection in Progress web page will be displayed, see Figure 3-11. The new IP address of the Wireless Evaluation Board will be displayed on the LCD after the connection to the device is established.

**Note:** The IP address display on the LCD may take some time to appear because the device has to go through the Dynamic Host Configuration Protocol (DHCP) process for acquiring an IP address.

**FIGURE 3-11: RECONNECTION**

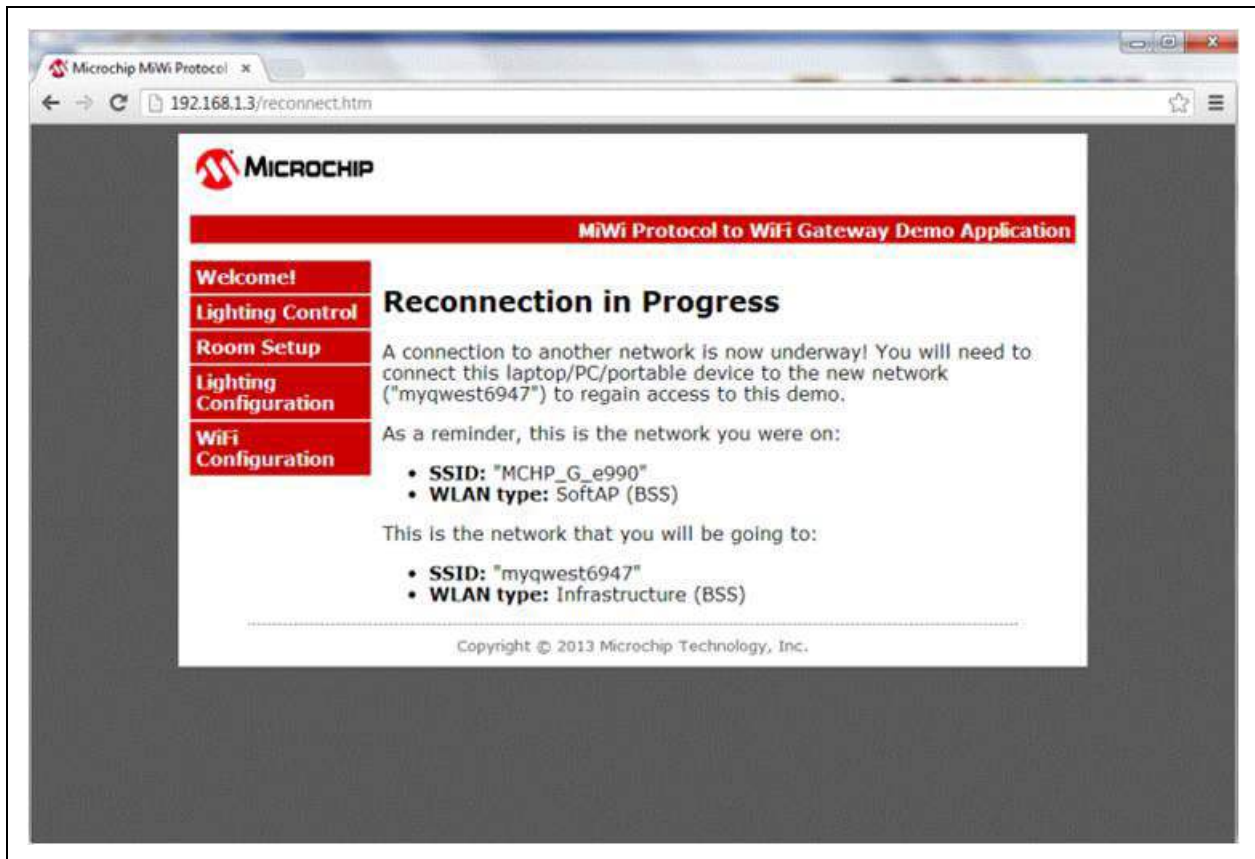

## 3.4 FIRMWARE UPDATE

The updates for the MiWi Protocol to Wi-Fi Wireless Demo Kit will be available in the Microchip Library of Applications (MLA) from the Microchip web site ([www.microchip.com/mla](http://www.microchip.com/mla)). The project source for the Wireless Evaluation Board is available in the Microchip Solutions\Combo\MiWi Protocol to Wi-Fi Gateway Demo Board\Wireless Eval Board and the project source for the MiWi Demo Board is available in the Microchip Solutions\Combo\MiWi Protocol to Wi-Fi Gateway Demo Board\MiWi Demo Board.

To program the MiWi Demo Board and the Wireless Evaluation Board, align the 6-pin ICSP™ adaptor to the PICKit 2 style programming header of the board and program them. For more information on programming, refer to MPLAB® X IDE documentation on programming and the tool's (MPLAB REAL ICE In-Circuit Emulator, PICKit 3 programmer or MPLAB ICD 3) user's guide from the Microchip web site ([www.microchip.com](http://www.microchip.com)).

**Note:** For more information on how to update the web pages and customize the demo, refer to the TCP/IP stack help and MiWi DE help files in the MLA (Microchip Solutions\Microchip\Help).

# MiWi™ Protocol to Wi-Fi® Wireless Demo Kit User's Guide

---

---

NOTES:



---

## Chapter 4. Self-Test Procedure

---

The Self-Test mode that is available on the Wireless Evaluation Board can be used to evaluate the hardware, if required.

### 4.1 SELF-TEST PROCEDURE

To evaluate the hardware, use the following self-test procedure:

1. Power-up the board using a mini-B USB cable or a 9V external power supply.
2. For the hardware to boot up in Self-Test mode or Acceptance Test mode. Press and hold the **SW0** push button on the device and then turn the board ON (move the switch SW3 from the OFF to the ON position). Release the **SW0** push button after 2 seconds.
3. Ensure the LCD splash screen displays the “Self Test Mode Wireless EvalBrd” message or else repeat Step 2.
4. Testing LEDs and push buttons:
  - If the green LED on the board is ON and the “LED0 On? SW0:Yes” message appears on the LCD, press the **SW0** push button to continue
  - If the yellow LED on the board turns ON and the “LED1 On? SW1:Yes” message appears on the LCD, press the **SW1** push button to continue
  - If the red LED on the board turns ON and the “LED2 On? SW2:Yes” message appears on the LCD, press the **SW2** push button to continue
5. Testing the Analog Potentiometer – The LCD prompts the user to test the analog potentiometer reading. When the display prompts with the “Test Analog POT SW0: Yes SW1: Exit” message, press the **SW0** push button to continue. The user can rotate the potentiometer and check the reading on the LCD. It should vary from 0-1023 (the potentiometer moves in a clockwise direction). Press the **SW1** push button to proceed.
6. Testing the Temperature Sensor – The LCD displays the “Test Temperature Sensor SW0:Yes SW1: Exit” message. Press the **SW0** push button to continue with the test; the temperature reading will be displayed on LCD line 1. There might be a slight fluctuation in the temperature reading as it is not averaged across a large number of readings, but if it is around room temperature, press the **SW1** push button to proceed.
7. Testing EEPROM – The result of the EEPROM test will be updated on the LCD. Ensure the status indicates PASS and then press the **SW0** push button.
8. Testing Flash – The Flash test results will be updated on the LCD. Ensure the status indicates PASS, and then press the **SW0** push button to continue.

9. Testing Radio (MiWi) – The LCD displays the PASS or FAIL status of the MRF24J40MA Radio hardware connections. Ensure the test result indicates PASS, and then press the **SW0** push button to continue with the test.
10. Testing Wi-Fi SPI and UART – The LCD displays the “Testing UART” message. After verifying the SPI connections to the Wi-Fi modules, the LCD message changes to “Printing Label”, and the unique MAC address of the module will be displayed on the UART. It ensures the MAC address is not all zeros, and confirms all the components on the device are working.

- Note 1:** For the UART, use BAUD\_RATE 9600, DATA\_BITS 8, PARITY NONE, STOP\_BITS 1, and FLOW\_CONTROL NONE settings.
- 2:** Using the mini-B USB connection with the board requires the device driver for the MCP2200 to be preinstalled on a Windows operating system to use the UART.
- 3:** To use USB with the MCP2200 as a UART, the user may need to install device drivers for the MCP2200. For more information, visit the Microchip web site ([www.microchip.com/mcp2200](http://www.microchip.com/mcp2200)).



## **Appendix A. Wireless Evaluation Board Schematic**

---

---

### **A.1 INTRODUCTION**

This appendix includes:

- [Wireless Evaluation Board Schematics](#)
- [Wireless Evaluation Board PCB Layout](#)
- [Wireless Evaluation Board Bill of Materials](#)

### **A.2 WIRELESS EVALUATION BOARD SCHEMATICS**

[Figure A-1](#) and [Figure A-2](#) illustrate the Wireless Evaluation Board schematics.

FIGURE A-1: WIRELESS EVALUATION BOARD SCHEMATIC 1 OF 2

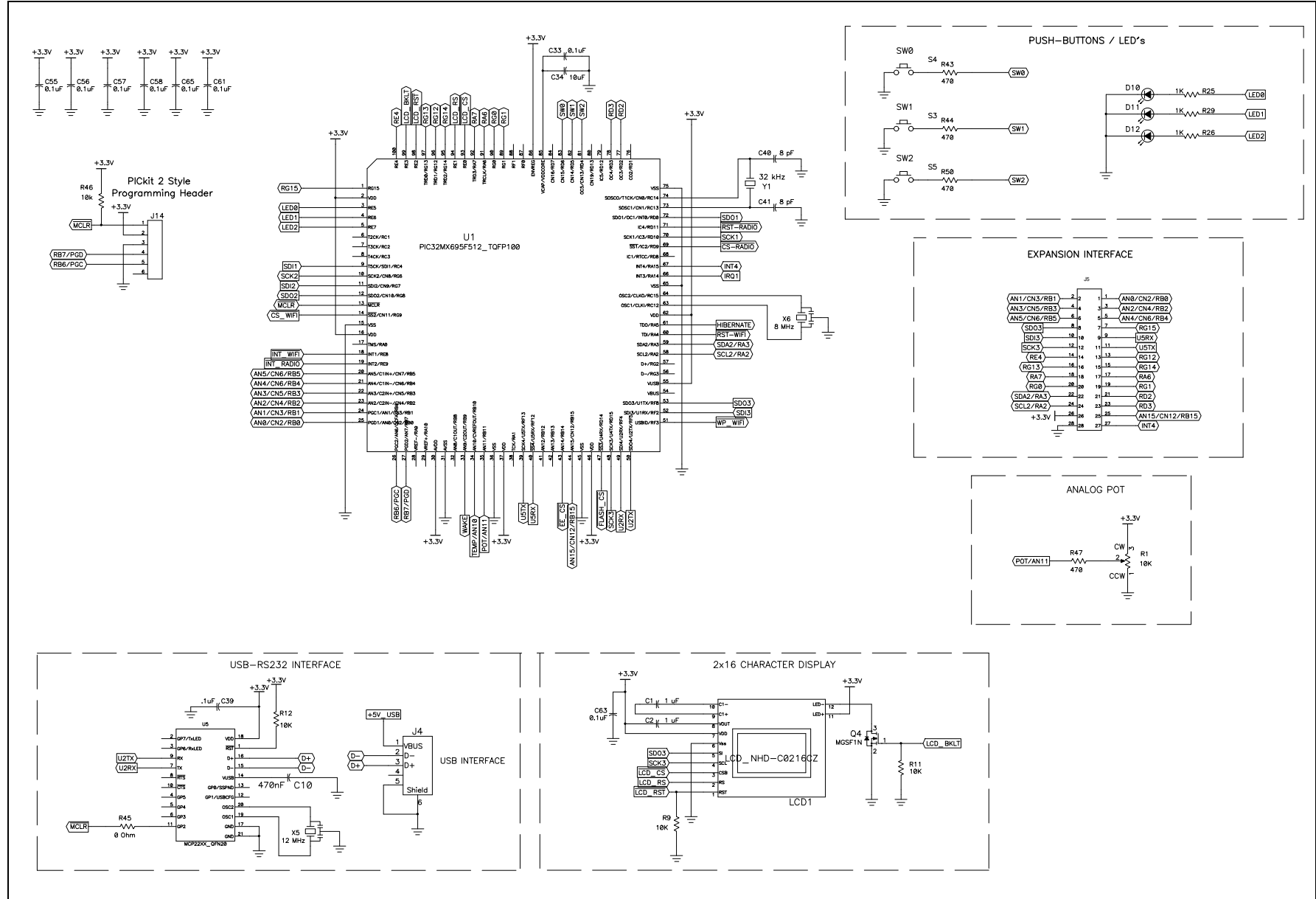
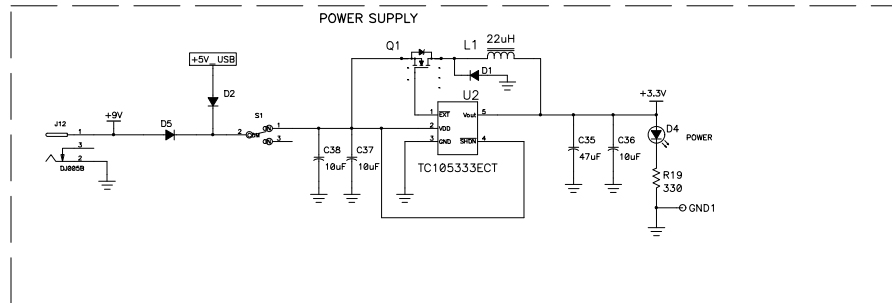
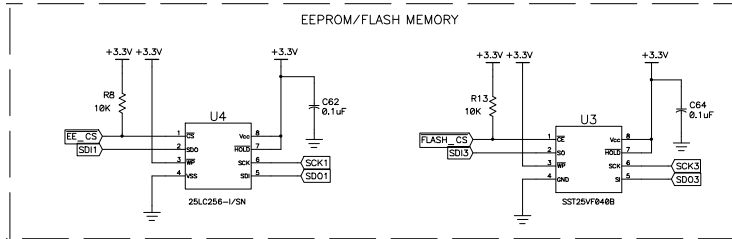
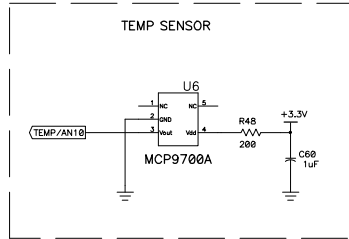
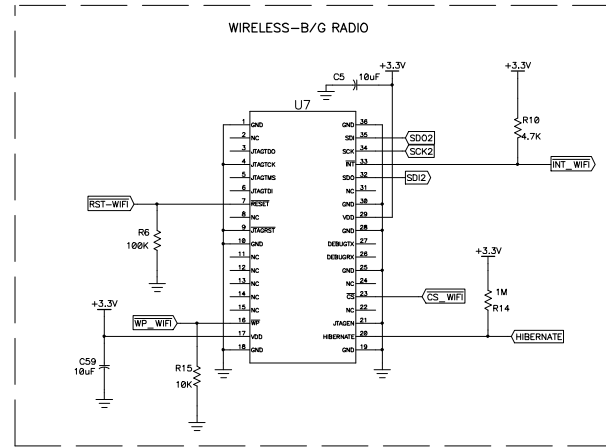
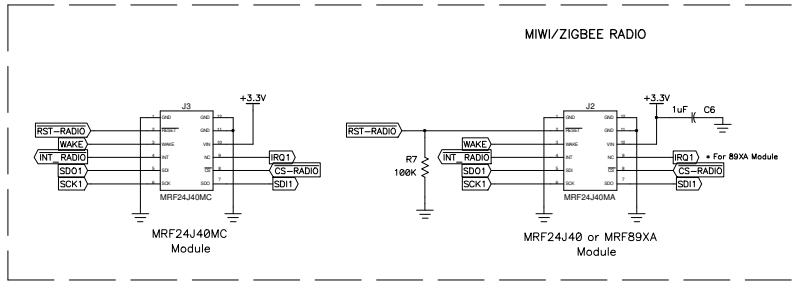



FIGURE A-2: WIRELESS EVALUATION BOARD SCHEMATIC 2 OF 2



### A.3 WIRELESS EVALUATION BOARD PCB LAYOUT

The Wireless Evaluation Board PCB is a 4-layer, high temperature FR4, 0.062 inch, plated through hole construction. [Figure A-3](#) illustrates the PCB top layer.

**FIGURE A-3: WIRELESS EVALUATION BOARD TOP SIDE ASSEMBLY**

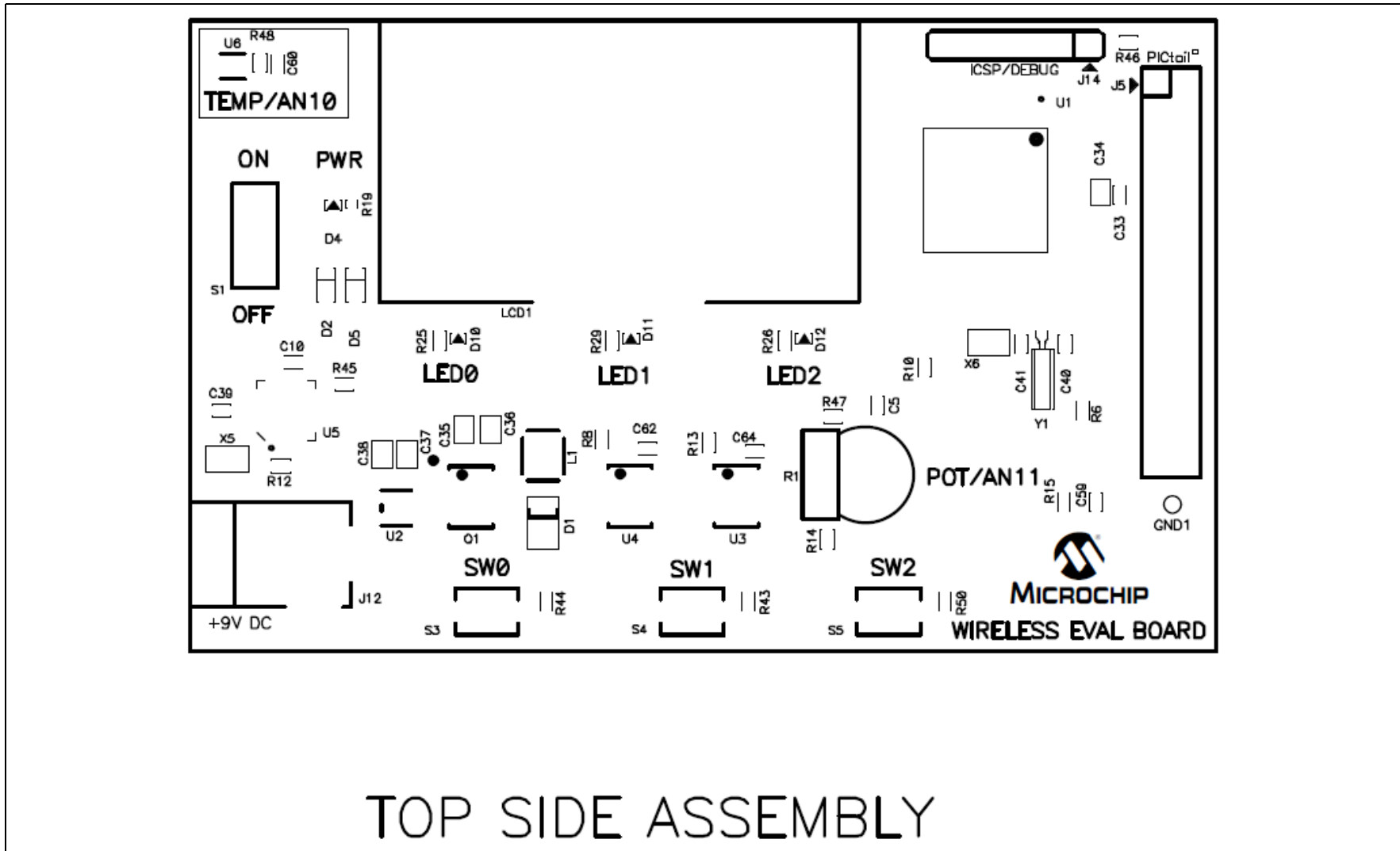

## A.4 WIRELESS EVALUATION BOARD BILL OF MATERIALS

Table A-1 provides the Wireless Evaluation Board BOM.

**TABLE A-1: WIRELESS EVALUATION BOARD BILL OF MATERIALS (BOM)**

Count	PCB10068 R1 Component Name	12/13/12 DMB Ref. Des	Value	Description	MFG Part Number	Manufacture	Dist. Part Number	Distributor
1	25LC2568_SOIC150	U4	25LC256-I/SN	IC EEPROM 256KBIT 10MHZ 8SOIC	25LC256-I/SN	Microchip Technology Inc.	25LC256-I/SN	Digi-Key
12	CAP0603	C55,C56,C57,C58,C60,C63,C39,C33,C62,C64,C65,C61	0.1 $\mu$ F	CAP CER 0.1UF 25V 10% X7R 0603	GRM188R71E104KA01D	Murata	490-1524-2-ND	Digi-Key
3	CAP0603	C1,C2,C6	1 $\mu$ F	CAP CER 1UF 6.3V 10% X5R 0603	GRM033R60J103KA01D	Murata	490-5403-2-ND	Digi-Key
2	CAP0603	C40,C41	8 pF	Capacitor, Ceramic, 50V, +/-0.5pF, C0G, SMT 0603	GRM1885C1H8R0DZ01D	Murata	490-1399-2-ND	Digi-Key
2	CAP0603	C5,C59	10 $\mu$ F	CAP CER 10UF 6.3V 20% X5R 0603	GRM188R60J106ME47D	Murata	490-3896-2-ND	Digi-Key
1	CAP0603	C10	470 $\mu$ F	CAP SMT, 470 nF 0603 CER 16V 10% X5R	C1608X5R1C474K	TDK Corporation	445-5152-2-ND	Digi-Key
4	CAP0805	C34,C36,C37,C38	10 $\mu$ F	Capacitor, Ceramic, 6.3V, +/-20%, X5R, SMT 0805	GRM21BR60J106ME19L	Murata Electronics North America	490-1718-2-ND	Digi-Key
1	CAP0805	C35	47 $\mu$ F	Ceramic capacitor, Surface mount	C2012X5R0J476M	TDK Corporation	445-5987-2-ND	Digi-Key
1	CONN_USB_MINI_B	J4	NA	USB Connectors MINI USB B-TYPE PLUG KIT SOLDER TAIL	806-KMBX-BPKITST30	Kycon	806-KMBX-BPKITST30	Mouser
1	CRYSTAL_MS3V-T1R	Y1	32 kHz	MS3V-T1R 32.768kHz +/-20 ppm 9 pF	MS3V-T1R 32.768kHz +/-20 ppm 9 pF	Micro Crystal	MS3V-T1R 32.768kHz +/-20 ppm 9 pF	Doveonline
1	DIODE-SMA	D1	3A 40V Schottkyn SMA	Lead-Mounted Silicon Rectifier, Diffused Junction	MBRA340T3GOSTR	On Semiconductor	MBRA340T3GOSTR-ND	Digi-Key
2	DIODE_SOD-123	D2,D5	DIODE SCHOTTKY 0.5A 20V SOD-123	Lead-Mounted Silicon Rectifier, Diffused Junction	MBR0520LT3GOSTR	On Semiconductor	MBR0520LT3GOSTR-ND	Digi-Key
1	DJ005B	J12	9V adaptor	CONN POWER JACK 2.5MM PCB CIRC	PJ-102B	CUI Inc	CP-102B-ND	Digi-Key
1	MRF24WGMA	U7	MRF24WGMA	2.4 GHz 802.11b Ultra Low Power Transceiver	MRF24WGMA	Microchip Technology Inc.	MRF24WGMA	Microchip Technology Inc.
1	HDR2X14	J5	—	HDR_2X14_O/E	PPPC142LFBN-RC	Sullins	S7117-ND	Digi-Key
1	ICSP_OS6	J14	DNP	HDR_1X6_TSW-106_RA	PBC06SBAN	Sullins	S1111E-06-ND	Digi-Key
1	INDUCTOR-ME3220-SMT	L1	22 $\mu$ H	Inductor, Iron-Core	ME3220-SMT	Coilcraft	ME3220-SMT	Coilcraft
1	LCD_NHD-C0216CZ	LCD1	NA	2x16 Character: 3VDD FSTN(+), WHITE LED backlight 3V, Transflective, 6:00, Wide Temp (-20 to +70c), Serial Interface, 1x10 hard pin, RoHS	LCD_NHD-C0216CZ	New Haven	LCD_NHD-C0216CZ	New Haven

TABLE A-1: WIRELESS EVALUATION BOARD BILL OF MATERIALS (BOM) (CONTINUED)

Count	PCB10068 R1 Component Name	12/13/12 DMB Ref. Des	Value	Description	MFG Part Number	Manufacture	Dist. Part Number	Distributor
1	LED_0805	D4	GREEN	Light Emitting Diode	SML-LXT0805GW-TR	LUMEX	67-1553-1-ND	Digi-Key
1	LED_LTL-PGK-TA	D10	GREEN	Light Emitting Diode	CMD67-21VGC/TR8	Chicago Miniature Lighting, LLC	L62805CT-ND	Digi-Key
1	LED_LTL-PGK-TA	D11	YELLOW	Light Emitting Diode	CMD67-21VYC/TR8	Chicago Miniature Lighting, LLC	L62807CT-ND	Digi-Key
1	LED_LTL-PGK-TA	D12	RED	Light Emitting Diode	CMD67-21VRC/TR8	Chicago Miniature Lighting, LLC	L62801CT-ND	Digi-Key
1	MCP22XX_QFN20	U5	MCP2200	IC USB TO UART 20QFN	MCP2200	Microchip Technology Inc.	MCP2200-I/MQ-ND	Digi-Key
1	MCP9700_SC70_5	U6	MCP9700A	IC SENSOR THERMAL 2.3V SC70-5	MCP9700A	Microchip Technology Inc.	MCP9700AT-E/LTTR-ND	Digi-Key
1	MOSFET SOIC	Q1	SI9435BDY	MOSFET P-CH 30V 4.1A 8-SOIC	SI9435BDY-T1-E3	Vishay Siliconix	SI9435BDY-T1-E3TR-ND	Digi-Key
1	MOSFET_MGSF1N	Q4	MGSF1N	MOSFET N-CH 30V 1.6A SOT-23	MGSF1N03LT1G	On Semiconductor	MGSF1N03LT1GOSTR-ND	Digi-Key
1	MRF24J40MA	J2	MRF24J40MA	MRF24J40MA	MRF24J40MA	Microchip Technology Inc.	MRF24J40MA	Microchip Technology Inc.
1	PIC32MX695F512L_QFN 64	U1	PIC32MX695F512L-80I/PT	PIC32MX695F512L-80I/PT	PIC32MX695F512L-80I/PT	Microchip Technology Inc.	PIC32MX695F512L-80I/PT	Microchip Technology Inc.
1	RES0603	R45	0Ω	RES 0.0Ω 1/10W 0603 SMD	ERJ-3GEY0R00V	PANASONIC	P0.GCT-ND	Digi-Key
1	RES0603	R48	200Ω	RES 200Ω 1/10W 5% 0603 SMD	ERJ-3GEYJ201V	PANASONIC	P200GTR-ND	Digi-Key
3	RES0603	R25,R26,R29	1K	RES 1.0 KΩ 1/10W 5% 0603 SMD	ERJ-3GEYJ102V	PANASONIC	P1.0KGTR-ND	Digi-Key
1	RES0603	R14	1M	RES 1.0 MΩ 1/10W 5% 0603 SMD	ERJ-3GEYJ105V	PANASONIC	P1.0MGTR-ND	Digi-Key
1	RES0603	R10	4.7K	RES 4.7 KΩ 1/10W 5% 0603 SMD	ERJ-3GEYJ472V	PANASONIC	P4.7KGTR-ND	Digi-Key
1	RES0603	R46,R8,R9,R11,R12,R13,R15	10k	RES 10 KΩ 1/10W 5% 0603 SMD	ERJ-3GEYJ103V	PANASONIC	P10KGTR-ND	Digi-Key
1	Through hole 3 lead	R1	10k	POT 10K Thumbwheel	3352T-1-103LF	Bournes	3352T-103LF-ND	Digi-Key
2	RES0603	R6,R7	100K	RES 100 KΩ 1/10W 5% 0603 SMD	ERJ-3GEYJ104V	PANASONIC	P100KGCT-ND	Digi-Key
3	RES0603	R43,R44,R47,R50	470	RES 470Ω 1/10W 5% 0603 SMD	ERJ-3GEYJ471V	PANASONIC	P470GCT-ND	Digi-Key
1	RES_RC0603	R19	330	RES 330Ω 1/10W 5% 0603 SMD	ERJ-3GEYJ331V	PANASONIC	P330GCT-ND	Digi-Key
1	RESONATOR_CSTCE	X6	8 MHz	CER RESONATOR 8.00MHZ SMD	CSTCE8M00G55Z-R0	Murata Electronics North America	490-1219-1-ND	Digi-Key
1	RESONATOR_CSTCE	X5	12 MHz	CER RESONATOR 12.0MHZ SMD	CSTCE12M0G55-R0	Murata Electronics North America	490-1197-1-ND	Digi-Key
1	SST25VF040B_SOIC150	U3	SST25VF040B	IC FLASH SER 4MB 80MHZ SPI 8SOIC	SST25VF040B-80-4I-SAE	Microchip Technology Inc.	SST25VF040B-80-4I-SAE-ND	Digi-Key
1	SW-DPDT - JS202011SCQN	S1	NA	SWITCH SLIDE DPDT 6VDC 0.3A SMT	JS202011SCQN	C&K Components	401-2002-ND	Digi-Key
3	SW-EVQ-PJS04K	S3,S4,S5	NA	SWITCH TACTILE SPST-NO 0.05A 12V	PTS635SL25SMTR LFS	C&K Components	CKN9119TR-ND	Digi-Key

**TABLE A-1: WIRELESS EVALUATION BOARD BILL OF MATERIALS (BOM) (CONTINUED)**

Count	PCB10068 R1 Component Name	12/13/12 DMB Ref. Des	Value	Description	MFG Part Number	Manufacture	Dist. Part Number	Distributor
1	TC105333ECT_SOT23_5	U2	TC105333ECT	IC REG CTRLR BUCK PWM SOT23A-5	TC105333ECTTR	Microchip Technology Inc.	TC105333ECTTR-ND	Digi-Key
4	Rubber feet on bottom	—	NA	BUMPON TALL TAPER SQ .50X.23 BK	SJ5518-0	3M	SJ5518-0-ND	Digi-Key

# MiWi™ Protocol to Wi-Fi® Wireless Demo Kit User's Guide

---

---

NOTES:



## **Appendix B. MiWi™ Demo Board Schematic**

---

---

### **B.1 INTRODUCTION**

This appendix includes:

- [MiWi Demo Board Schematics](#)
- [MiWi Demo Board PCB Layout](#)
- [MiWi Demo Board Bill of Materials \(BOM\)](#)

### **B.2 MIWI DEMO BOARD SCHEMATICS**

[Figure B-1](#) through [Figure B-3](#) illustrate the MiWi Demo Board schematics.

FIGURE B-1: MiWi™ DEMO BOARD SCHEMATICS 1 OF 3

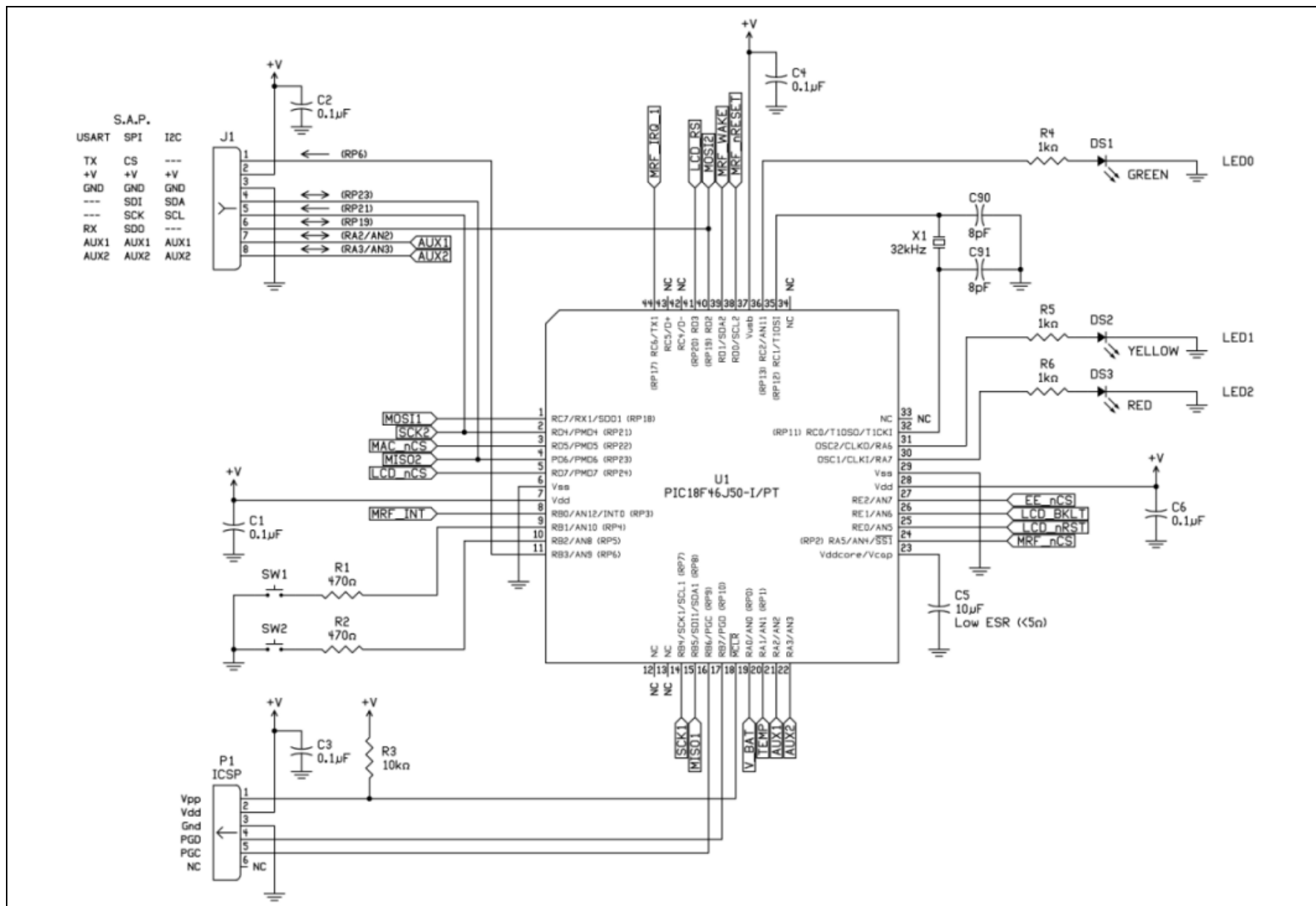



FIGURE B-2: MIWI™ DEMO BOARD SCHEMATICS 2 OF 3

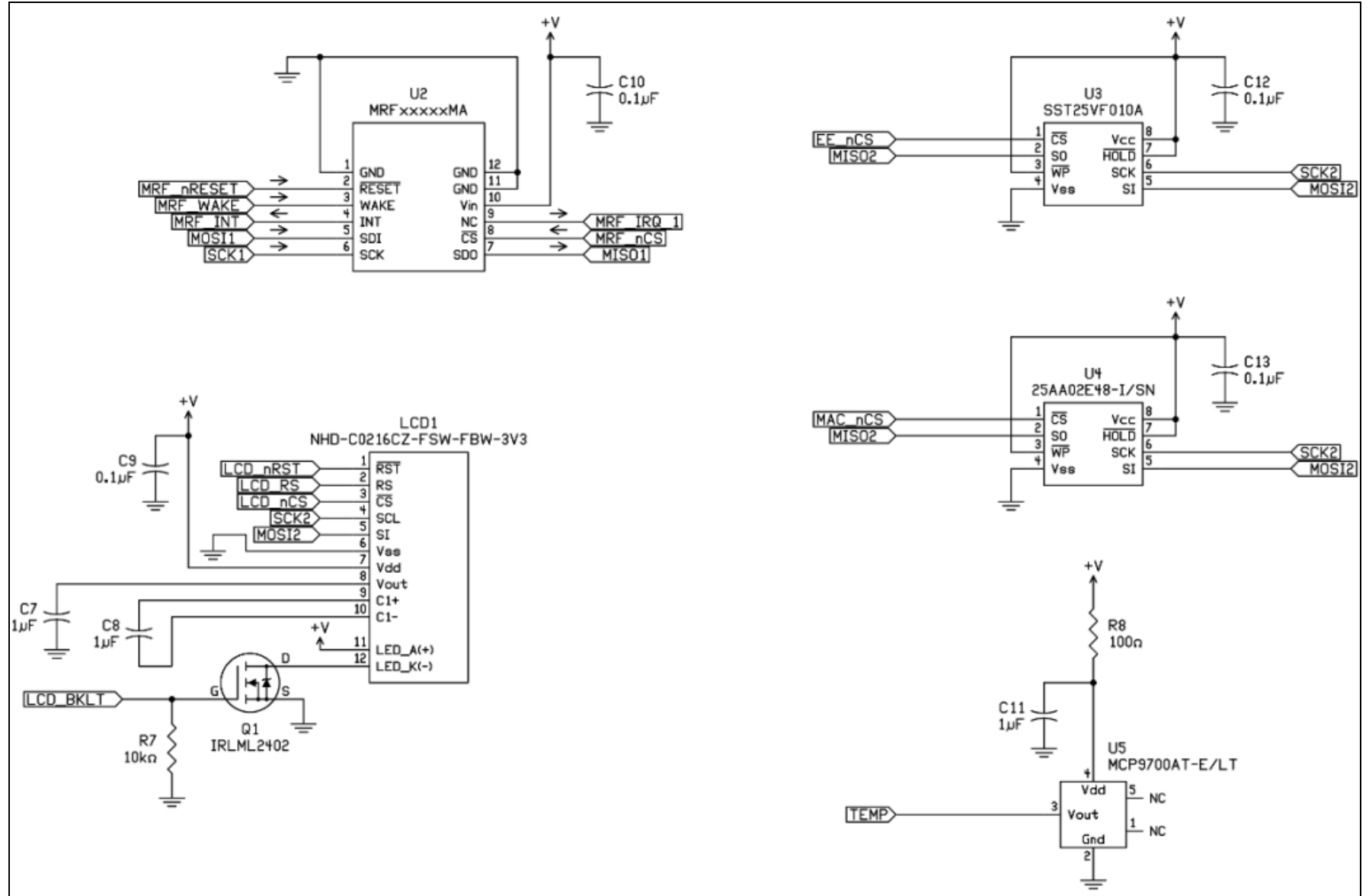
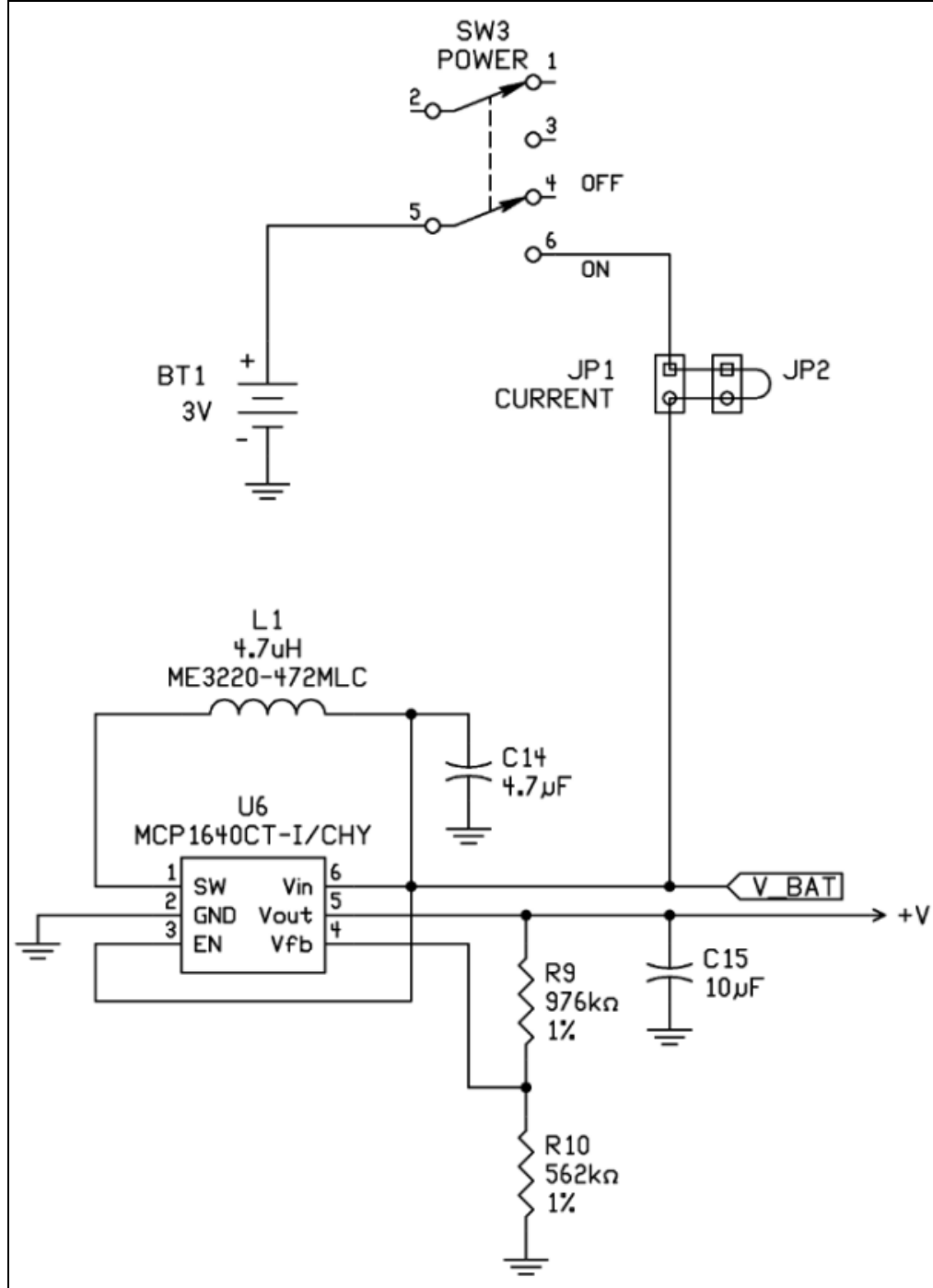

FIGURE B-3: MIWi™ DEMO BOARD SCHEMATICS 3 OF 3



## B.3 MiWi DEMO BOARD PCB LAYOUT

The MiWi Demo PCB is a 4-layer, high temperature FR4, 0.062 inch, plated through hole construction. [Figure B-4](#) through [Figure B-9](#) illustrate the PCB layers.

**FIGURE B-4: PCB TOP SILKSCREEN**

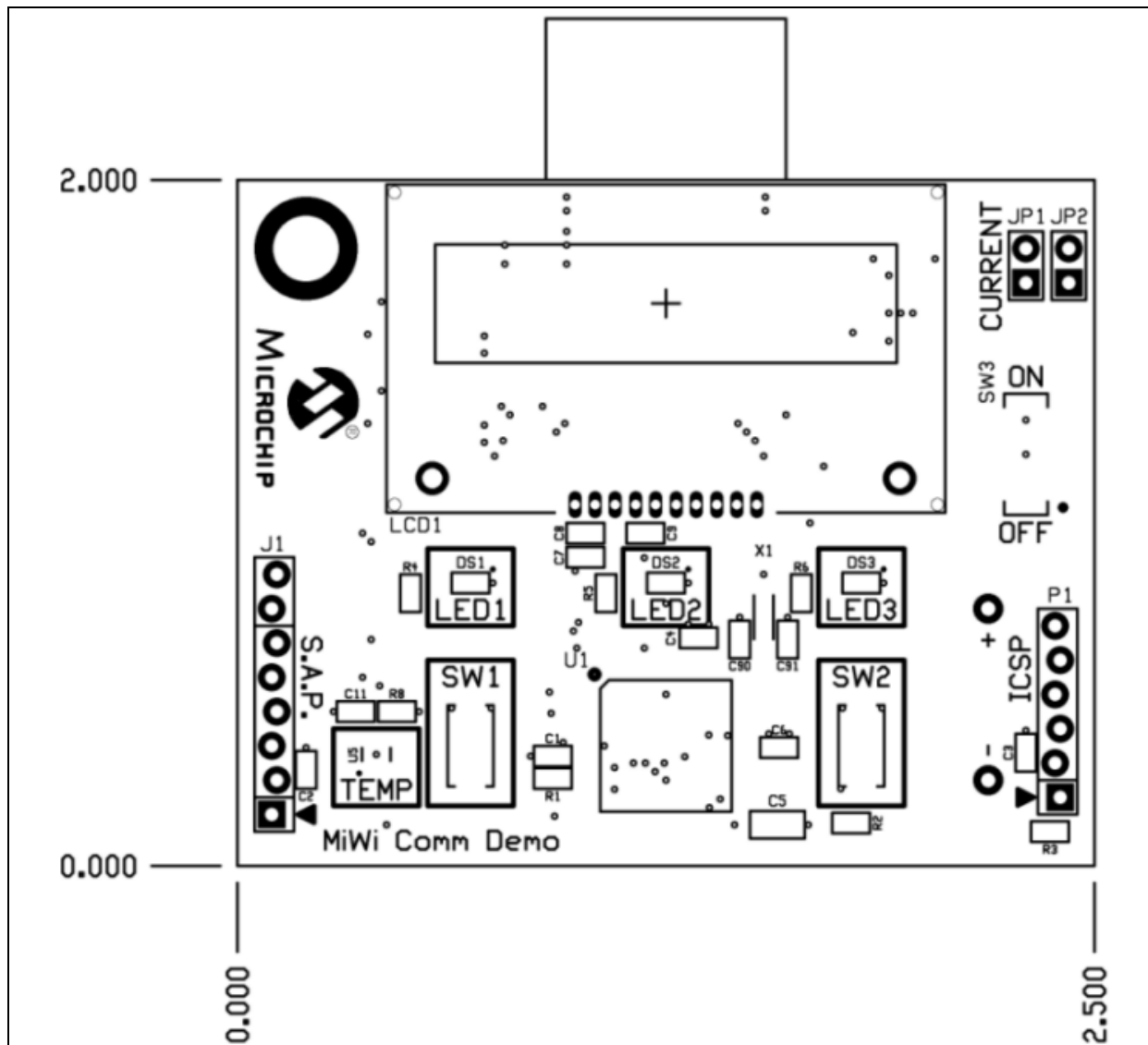

# MiWi™ Protocol to Wi-Fi® Wireless Demo Kit User's Guide

FIGURE B-5: PCB TOP COPPER

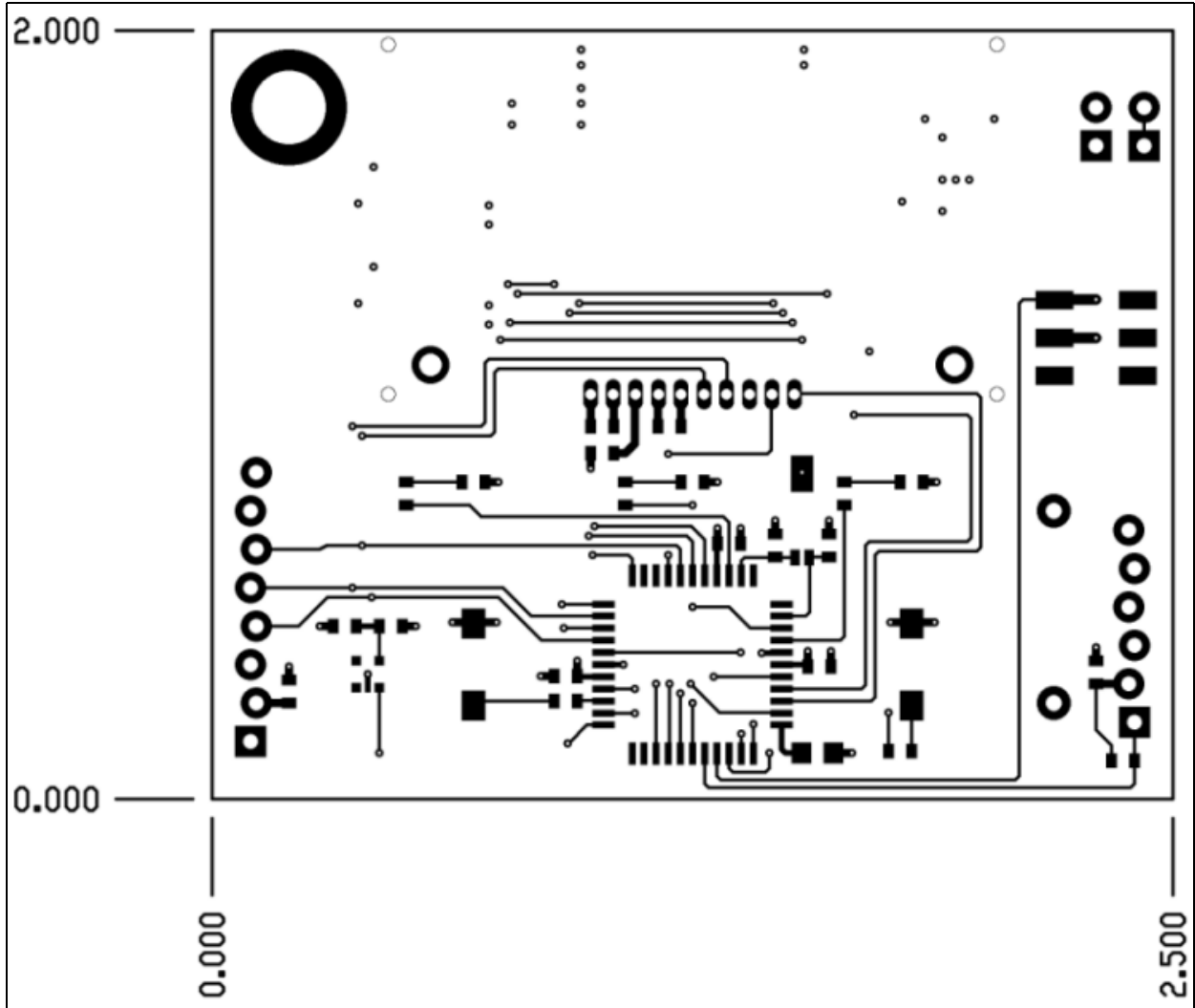



FIGURE B-7: PCB BOTTOM COPPER

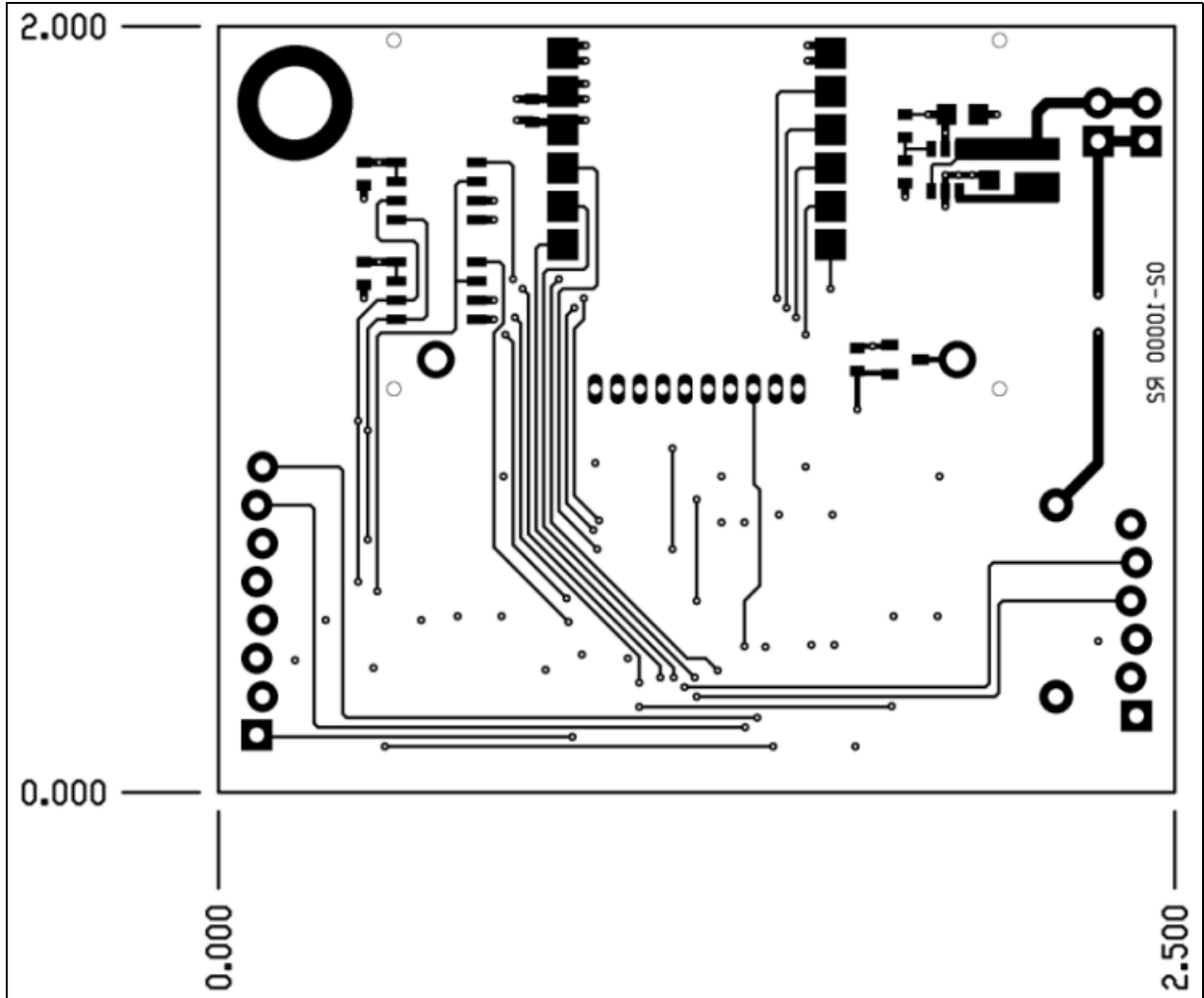

FIGURE B-8: PCB INNER LAYER 2 POWER

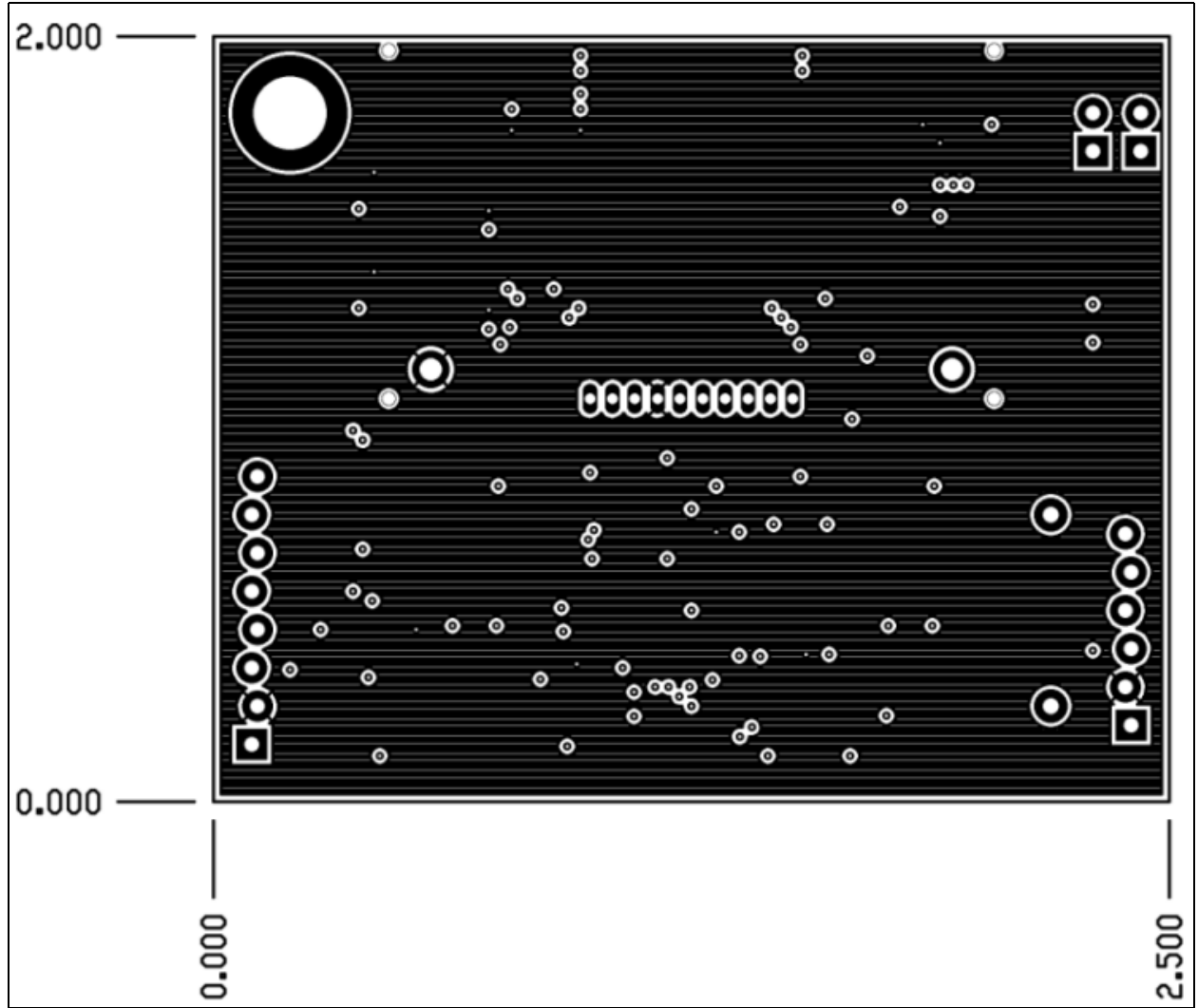
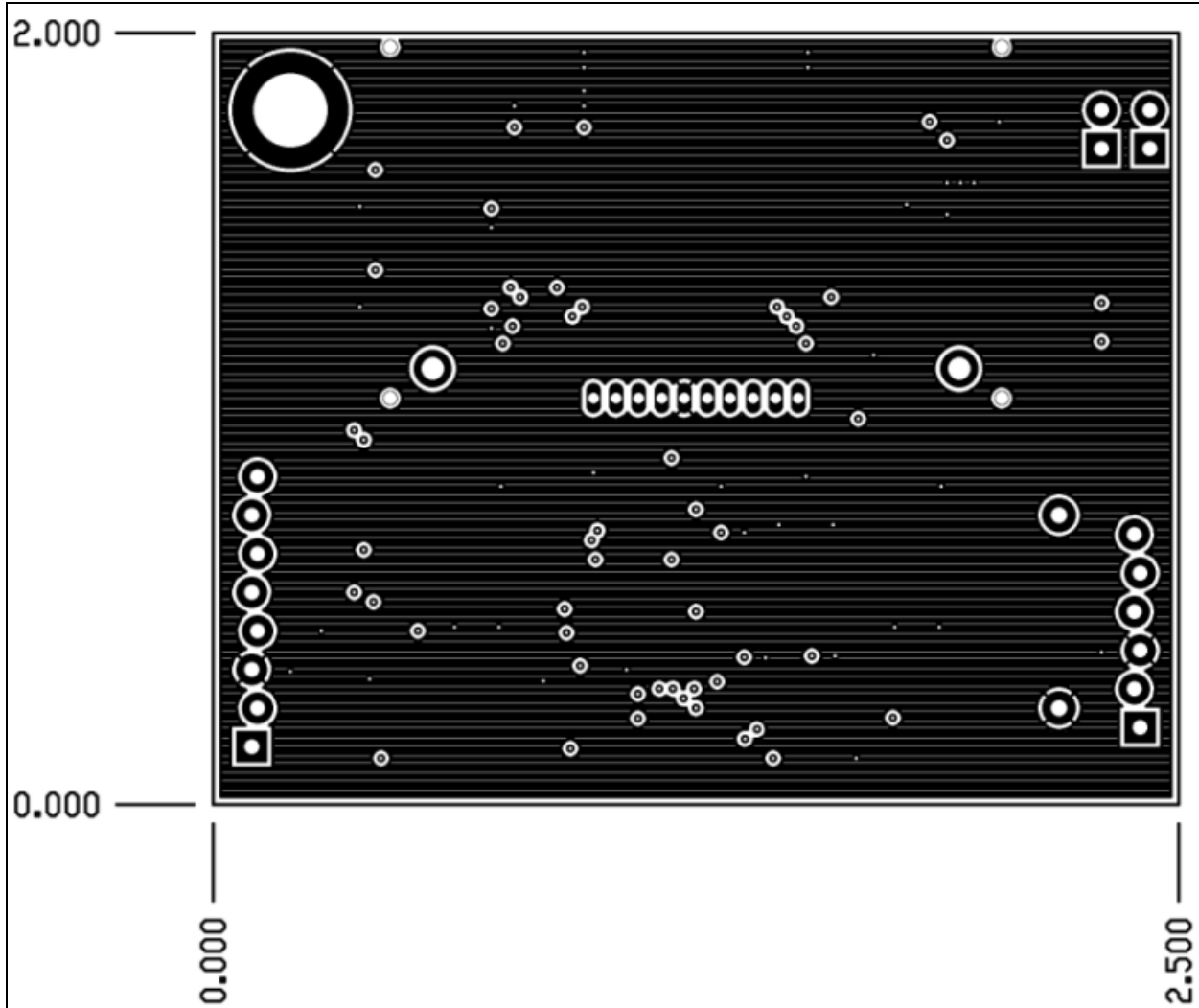

FIGURE B-9: PCB INNER LAYER 3 GROUND





## B.4 MiWi DEMO BOARD BILL OF MATERIALS (BOM)

Table B-1 provides the MiWi Demo Board BOM.

**TABLE B-1: MiWi™ DEMO BOARD BILL OF MATERIALS (BOM)**

Qty	Designator	Value	Description	Manufacturer	Manufacturer Part Number
1	BT1	—	HOLDER BATTERY 2CELL AAA PC MNT	Keystone Electronics	2468
2	C90, C91	8 pF	Capacitor, Ceramic, 50V, +/-0.5pF, C0G, SMT 0603	Murata Electronics North America	GRM1885C1H8R0DZ01D
9	C1, C2, C3, C4, C6, C9, C10, C12, C13	0.1 µF	Capacitor, Ceramic, 16V, +/-10%, X7R, SMT 0603	Murata Electronics North America	GRM188R71C104KA01D
3	C7, C8, C11	1 µF	Capacitor, Ceramic, 6.3V, +/-10%, X5R, SMT 0603	Murata Electronics North America	GRM188R60J105KA01D
1	C14	4.7 µF	Capacitor, Ceramic, 6.3V, +/-20%, X5R, SMT 0805	Murata Electronics North America	GRM219R60J475ME01D
3	C5, C15	10 µF	Capacitor, Ceramic, 6.3V, +/-20%, X5R, SMT 0805	Murata Electronics North America	GRM21BR60J106ME19L
1	DS1	Green	Diode, Light Emitting	OSRAM	LG Q971-KN-1-0-20-R18
1	DS2	Yellow	Diode, Light Emitting	OSRAM	LY Q976-P1S2-36
1	DS3	Red	Diode, Light Emitting	OSRAM	LS Q976-NR-1-0-20-R18
1	L1	4.7 µH	Inductor	Coilcraft	ME3220-472ML_
1	LCD1	—	LCD, 2x16 character	Newhaven Display Intl	NHD-C0216CZ-FSW-FBW-3V3
1	Q1	—	MOSFET N-CH 20V 1.2A SOT-23	IRLML2402	International Rectifier
1	R8	100Ω	Resistor, Thin Film, 5%, SMT 0603	Yageo	RC0603JR-07100RL
2	R1, R2	470Ω	Resistor, Thin Film, 5%, SMT 0603	Yageo	RC0603JR-07470RL
3	R4, R5, R6	1 kΩ	Resistor, Thin Film, 5%, SMT 0603	Yageo	RC0603JR-071KL
2	R3, R7	10 kΩ	Resistor, Thin Film, 5%, SMT 0603	Yageo	RC0603JR-0710KL
1	R10	562 kΩ	Resistor, Thin Film, 1%, SMT 0603	Yageo	RC0603FR-07562KL
1	R9	976 kΩ	Resistor, Thin Film, 1%, SMT 0603	Yageo	RC0603FR-07976KL
2	SW1, SW2	—	Switch, Pushbutton, Momentary, 6x3mm SMT	C&K Components	PTS635SL25SMTR LFS
1	SW3	—	Switch, Slide DPDT, 6VDC, 0.3A, SMT	C&K Components	JS202011SCQN
1	U4	—	25AA02E48-I/SN	Microchip Technology Inc.	25AA02E48-I/SN
1	U6	—	MCP1640CT-I/CH	Microchip Technology Inc.	MCP1640CT-I/CH
1	U5	—	MCP9700A	Microchip Technology Inc.	MCP9700AT-E/LT
1	U1	—	PIC18F46J50-I/PT	Microchip Technology Inc.	PIC18F46J50-I/PT
1	U3	—	SST25VF010A	Microchip Technology Inc.	SST25VF010A-33-4C-SAE
1	X1	—	Crystal, 32.768 kHz, 9 pF, +/- 20 ppm, SMT	Micro Crystal	MS3V-T1R 32.768kHz +/-20 ppm 9 pF
1	Stand Off	—	Stacking Spacer, 0.500 inch height	Keystone Electronics	8833
<b>868 MHz Version (DM182016-2)</b>					
1	U2	—	MRF89XAM8A-I/RM	Microchip Technology Inc.	MRF89XAM8A-I/RM
<b>915 MHz Version (DM182016-3)</b>					
1	U2	—	MRF89XAM9A-I/RM	Microchip Technology Inc.	MRF89XAM9A-I/RM

**TABLE B-1: MiWi™ DEMO BOARD BILL OF MATERIALS (BOM) (CONTINUED)**

Qty	Designator	Value	Description	Manufacturer	Manufacturer Part Number
<b>2.4 MHz Version (DM182016-1)</b>					
1	U2		MRF24J40MA-I/RM	Microchip Technology Inc.	MRF24J40MA-I/RM
<b>Separate Bag</b>					
1	J1		Socket, Right Angle, 6 pin, 0.100 inch spacing	Samtec	SSW-106-02-G-S-RA
1	P1		Header, Right Angle, 6 pin, 0.100 inch spacing	Samtec	TSW-106-08-T-S-RA
<b>Do Not Populate</b>					
0	JP1, JP2		Connector, Header, 2-pin, 0.100" spacing	SPC Technology	SPC20481



# MiWi™ PROTOCOL TO Wi-Fi® WIRELESS DEMO KIT USER'S GUIDE

## Index

<b>A</b>		<b>S</b>	
AAA Batteries.....	23	SPI .....	20
<b>B</b>		<b>T</b>	
BOM.....	8	Testing Analog Potentiometer.....	37
<b>C</b>		Testing EEPROM.....	37
Customer Notification Service.....	10	Testing Radio.....	38
Customer Support.....	10	Testing Temperature Sensor .....	37
<b>D</b>		Testing Wi-Fi® SPI and UART .....	38
DC Power.....	21	<b>U</b>	
Demonstration Application .....	15	UART .....	21
Documentation		USB.....	13, 15
Conventions.....	8	<b>W</b>	
Layout.....	7	Warranty Registration .....	9
<b>E</b>		Wi-Fi Demo Kit .....	13
EEPROM .....	20	Wi-Fi Gateway Demo Board .....	23
<b>I</b>		Wi-Fi Transceiver Module .....	19
IEEE 802.15.4.....	15	Wireless Evaluation Board .....	7
Internet Address.....	10	Wireless Evaluation Board Schematics .....	39
IP Address .....	27	WWW Address.....	10
<b>L</b>			
LCD.....	20		
Lighting Control.....	32		
<b>M</b>			
MAC Address.....	17		
Microchip Internet Web Site.....	10		
Microchip Library of Applications (MLA).....	23		
Microchip Wi-Fi Products .....	23		
MiWi .....	7		
MiWi Demo Board.....	7		
MiWi Demo PCB .....	51		
MiWi Protocol.....	13		
<b>P</b>			
P2P Network .....	13		
PCB.....	42		
PCB Layer.....	51		
PCB Top Layer .....	42		
PIC® Microcontroller .....	15		
PICtail .....	21		
Power Supply .....	21		
PWR LED Light.....	24		
<b>R</b>			
Recommended Reading .....	9		
RF Transceiver Module.....	17		



# MICROCHIP

## Worldwide Sales and Service

### AMERICAS

**Corporate Office**  
2355 West Chandler Blvd.  
Chandler, AZ 85224-6199  
Tel: 480-792-7200  
Fax: 480-792-7277  
Technical Support:  
<http://www.microchip.com/support>  
Web Address:  
[www.microchip.com](http://www.microchip.com)

**Atlanta**  
Duluth, GA  
Tel: 678-957-9614  
Fax: 678-957-1455

**Boston**  
Westborough, MA  
Tel: 774-760-0087  
Fax: 774-760-0088

**Chicago**  
Itasca, IL  
Tel: 630-285-0071  
Fax: 630-285-0075

**Cleveland**  
Independence, OH  
Tel: 216-447-0464  
Fax: 216-447-0643

**Dallas**  
Addison, TX  
Tel: 972-818-7423  
Fax: 972-818-2924

**Detroit**  
Farmington Hills, MI  
Tel: 248-538-2250  
Fax: 248-538-2260

**Indianapolis**  
Noblesville, IN  
Tel: 317-773-8323  
Fax: 317-773-5453

**Los Angeles**  
Mission Viejo, CA  
Tel: 949-462-9523  
Fax: 949-462-9608

**Santa Clara**  
Santa Clara, CA  
Tel: 408-961-6444  
Fax: 408-961-6445

**Toronto**  
Mississauga, Ontario,  
Canada  
Tel: 905-673-0699  
Fax: 905-673-6509

### ASIA/PACIFIC

**Asia Pacific Office**  
Suites 3707-14, 37th Floor  
Tower 6, The Gateway  
Harbour City, Kowloon  
Hong Kong  
Tel: 852-2401-1200  
Fax: 852-2401-3431

**Australia - Sydney**  
Tel: 61-2-9868-6733  
Fax: 61-2-9868-6755

**China - Beijing**  
Tel: 86-10-8569-7000  
Fax: 86-10-8528-2104

**China - Chengdu**  
Tel: 86-28-8665-5511  
Fax: 86-28-8665-7889

**China - Chongqing**  
Tel: 86-23-8980-9588  
Fax: 86-23-8980-9500

**China - Hangzhou**  
Tel: 86-571-2819-3187  
Fax: 86-571-2819-3189

**China - Hong Kong SAR**  
Tel: 852-2943-5100  
Fax: 852-2401-3431

**China - Nanjing**  
Tel: 86-25-8473-2460  
Fax: 86-25-8473-2470

**China - Qingdao**  
Tel: 86-532-8502-7355  
Fax: 86-532-8502-7205

**China - Shanghai**  
Tel: 86-21-5407-5533  
Fax: 86-21-5407-5066

**China - Shenyang**  
Tel: 86-24-2334-2829  
Fax: 86-24-2334-2393

**China - Shenzhen**  
Tel: 86-755-8864-2200  
Fax: 86-755-8203-1760

**China - Wuhan**  
Tel: 86-27-5980-5300  
Fax: 86-27-5980-5118

**China - Xian**  
Tel: 86-29-8833-7252  
Fax: 86-29-8833-7256

**China - Xiamen**  
Tel: 86-592-2388138  
Fax: 86-592-2388130

**China - Zhuhai**  
Tel: 86-756-3210040  
Fax: 86-756-3210049

### ASIA/PACIFIC

**India - Bangalore**  
Tel: 91-80-3090-4444  
Fax: 91-80-3090-4123

**India - New Delhi**  
Tel: 91-11-4160-8631  
Fax: 91-11-4160-8632

**India - Pune**  
Tel: 91-20-2566-1512  
Fax: 91-20-2566-1513

**Japan - Osaka**  
Tel: 81-6-6152-7160  
Fax: 81-6-6152-9310

**Japan - Tokyo**  
Tel: 81-3-6880-3770  
Fax: 81-3-6880-3771

**Korea - Daegu**  
Tel: 82-53-744-4301  
Fax: 82-53-744-4302

**Korea - Seoul**  
Tel: 82-2-554-7200  
Fax: 82-2-558-5932 or  
82-2-558-5934

**Malaysia - Kuala Lumpur**  
Tel: 60-3-6201-9857  
Fax: 60-3-6201-9859

**Malaysia - Penang**  
Tel: 60-4-227-8870  
Fax: 60-4-227-4068

**Philippines - Manila**  
Tel: 63-2-634-9065  
Fax: 63-2-634-9069

**Singapore**  
Tel: 65-6334-8870  
Fax: 65-6334-8850

**Taiwan - Hsin Chu**  
Tel: 886-3-5778-366  
Fax: 886-3-5770-955

**Taiwan - Kaohsiung**  
Tel: 886-7-213-7828  
Fax: 886-7-330-9305

**Taiwan - Taipei**  
Tel: 886-2-2508-8600  
Fax: 886-2-2508-0102

**Thailand - Bangkok**  
Tel: 66-2-694-1351  
Fax: 66-2-694-1350

### EUROPE

**Austria - Wels**  
Tel: 43-7242-2244-39  
Fax: 43-7242-2244-393

**Denmark - Copenhagen**  
Tel: 45-4450-2828  
Fax: 45-4485-2829

**France - Paris**  
Tel: 33-1-69-53-63-20  
Fax: 33-1-69-30-90-79

**Germany - Munich**  
Tel: 49-89-627-144-0  
Fax: 49-89-627-144-44

**Italy - Milan**  
Tel: 39-0331-742611  
Fax: 39-0331-466781

**Netherlands - Druenen**  
Tel: 31-416-690399  
Fax: 31-416-690340

**Spain - Madrid**  
Tel: 34-91-708-08-90  
Fax: 34-91-708-08-91

**UK - Wokingham**  
Tel: 44-118-921-5869  
Fax: 44-118-921-5820

11/29/12