

5A Fast-Response LDO Regulators

Features

- Fast Transient Response
- 5A Current Capability
- 700 mV Dropout Voltage at Full Load
- Low Ground Current
- Accurate 1% Tolerance
- “Zero” Current Shutdown Mode (MIC29512)
- Fixed Voltage and Adjustable Versions

Applications

- Pentium™, Pentium Plus™, and Power PC™ Processor Supplies
- High-Efficiency “Green” Computer Systems
- High-Efficiency Linear Power Supplies
- High-Efficiency Switching Supply Post Regulator
- Battery-Powered Equipment

General Description

The MIC29510 and MIC29512 are high-current, high-accuracy, low-dropout voltage regulators that feature fast transient recovery from input voltage surges and output load current changes. These regulators use a PNP pass element that features Microchip’s proprietary Super β PNP process.

The MIC29510/2 are available in two versions: the three pin fixed output MIC29510 and the five pin adjustable output voltage MIC29512. Both versions are fully protected against overcurrent faults, reversed input polarity, reversed lead insertion, overtemperature operation, and positive and negative transient voltage spikes.

A TTL-compatible enable (EN) control pin supports external on/off control. If on/off control is not required, the device may be continuously enabled by connecting EN to IN.

The MIC29510/2 are available in the standard three and five pin TO-220 packages with an operating junction temperature range of 0°C to +125°C.

For applications that require even lower dropout voltage, input voltage greater than 16V, or an error flag, see the MIC29500/29501/29502/29503.

Package Types

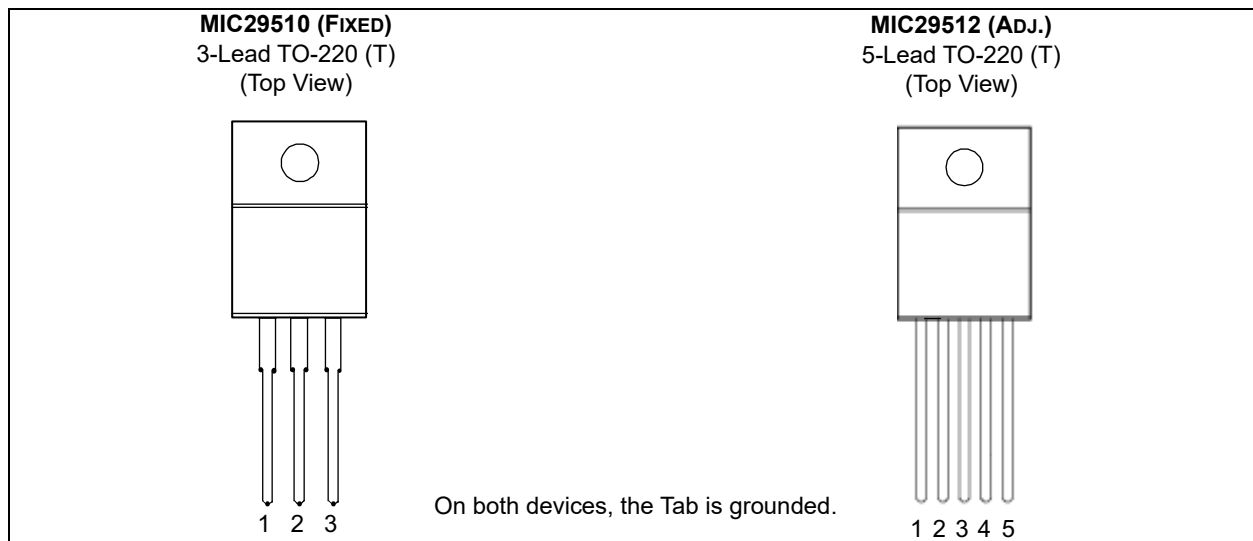

MIC29510/12

Typical Application Circuits

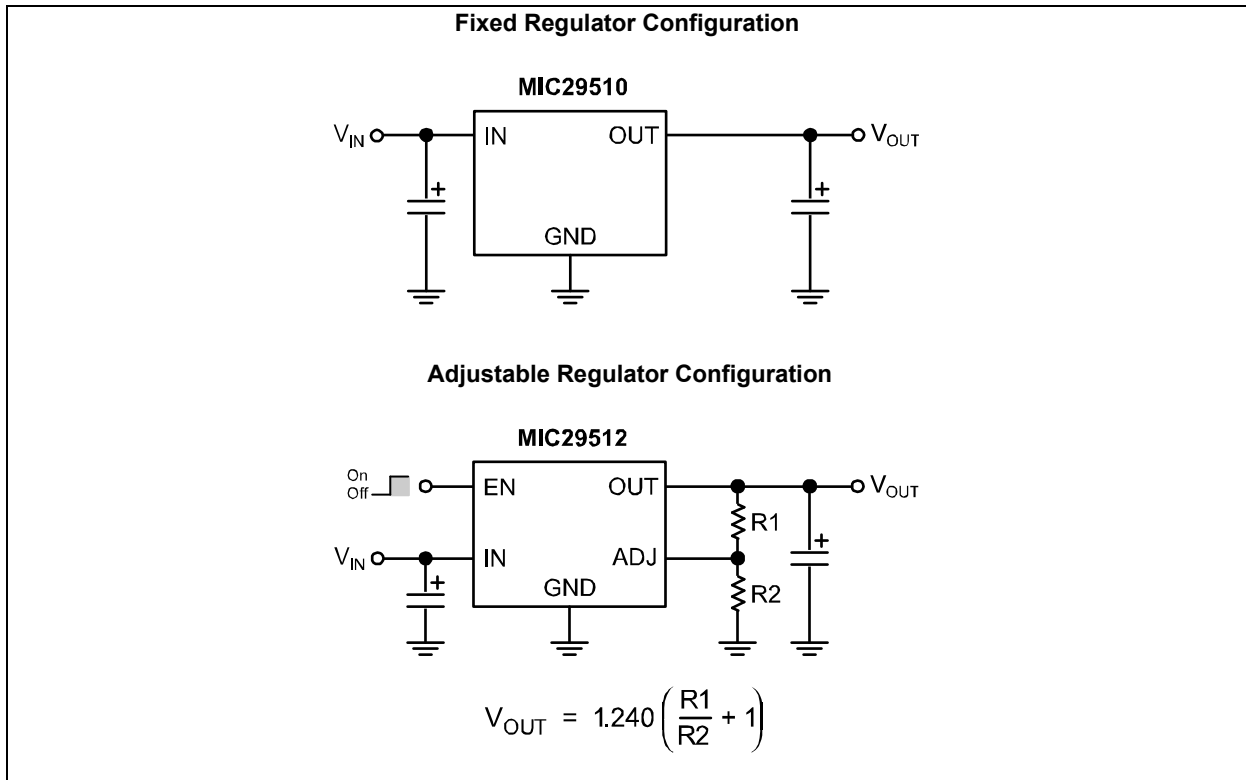

Functional Block Diagram

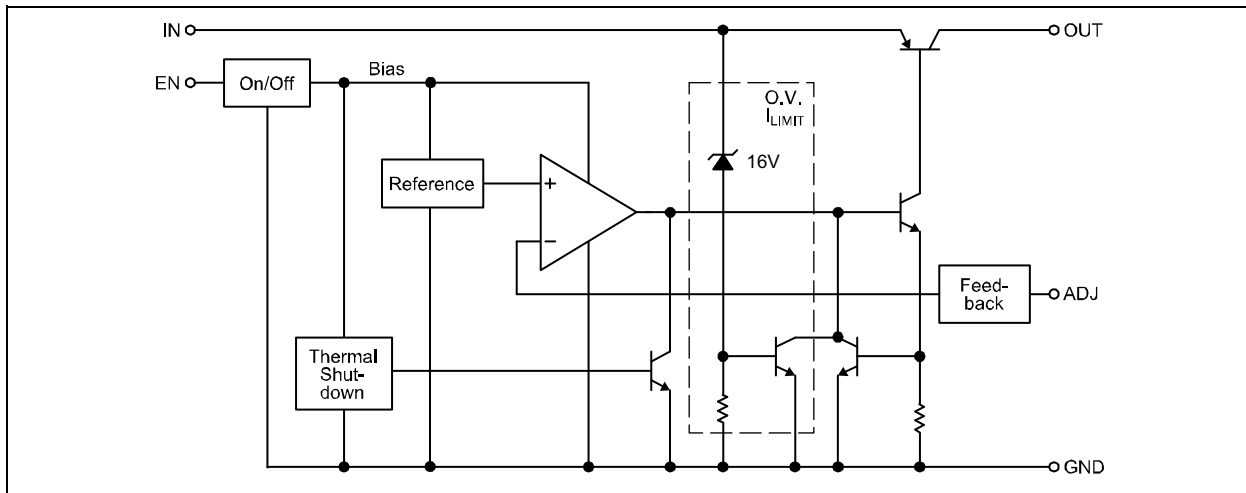

1.0 ELECTRICAL CHARACTERISTICS

Absolute Maximum Ratings †

Input Supply Voltage	-20V to +20V
Power Dissipation	Internally Limited

† **Notice:** Stresses above those listed under “Absolute Maximum Ratings” may cause permanent damage to the device. This is a stress rating only and functional operation of the device at those or any other conditions above those indicated in the operational sections of this specification is not intended. Exposure to maximum rating conditions for extended periods may affect device reliability.

Note 1: Devices are ESD sensitive. Handling precautions are recommended.

2: The maximum continuous supply voltage is 16V.

ELECTRICAL CHARACTERISTICS

Electrical Characteristics: All measurements at $T_J = +25^\circ\text{C}$ unless otherwise noted. **Bold** values are guaranteed across the operating temperature range.

Parameter	Min.	Typ.	Max.	Units	Conditions
Output Voltage Accuracy	-2	—	2	%	$10\text{ mA} \leq I_O \leq I_{FL}$, $(V_{OUT} + 1V) \leq V_{IN} \leq 8V$ (Note 1)
Line Regulation	—	0.06	0.5	%	$I_O = 10\text{ mA}$, $(V_{OUT} + 1V) \leq V_{IN} \leq 8V$
Load Regulation	—	0.2	1	%	$V_{IN} = V_{OUT} + 1V$, $10\text{ mA} \leq I_{OUT} \leq I_{FULL\ LOAD}$ (Note 1, Note 5)
Output Voltage Temperature Coefficient ($\Delta V_O/\Delta T$)	—	20	100	ppm/ $^\circ\text{C}$	Note 5
Dropout Voltage	—	80	200	mV	$\Delta V_{OUT} = -1\%$ (Note 2), $I_O = 100\text{ mA}$
	—	200	—		$\Delta V_{OUT} = -1\%$ (Note 2), $I_O = 750\text{ mA}$
	—	320	—		$\Delta V_{OUT} = -1\%$ (Note 2), $I_O = 1.5A$
	—	500	—		$\Delta V_{OUT} = -1\%$ (Note 2), $I_O = 3A$
	—	700	1000		$\Delta V_{OUT} = -1\%$ (Note 2), $I_O = 5A$
Ground Current	—	3	20	mA	$I_O = 750\text{ mA}$, $V_{IN} = V_{OUT} + 1V$
	—	10	—		$I_O = 1.5A$, $V_{IN} = V_{OUT} + 1V$
	—	36	—		$I_O = 3A$, $V_{IN} = V_{OUT} + 1V$
	—	100	150		$I_O = 5A$, $V_{IN} = V_{OUT} + 1V$
Ground Pin Current at Dropout	—	2	3	mA	$V_{IN} = 0.5V$ less than specified V_{OUT} . $I_{OUT} = 10\text{ mA}$

Note 1: Full Load current is defined as 5A for the MIC29510/29512. For testing, V_{OUT} is programmed to 5V.

2: Dropout voltage defined as the input-to-output differential when the output voltage drops to 99% of its nominal value with $V_{OUT} + 1V$ applied to V_{IN} .

3: For this test, V_{IN} is the larger of 8V or $V_{OUT} + 3V$.

4: Ground pin current is regulator quiescent current. Total current drawn from the source is the sum of the load current plus the ground pin current.

5: Output voltage temperature coefficient is defined as the worst case voltage change divided by the total temperature range.

6: $V_{REF} \leq V_{OUT} \leq (V_{IN} - 1V)$, $2.4V \leq V_{IN} \leq 16V$, $10\text{ mA} < I_L \leq I_{FL}$, $T_J \leq T_{J(MAX)}$.

7: $V_{EN} \leq 0.8V$ and $V_{IN} \leq 8V$, $V_{OUT} = 0$.

MIC29510/12

ELECTRICAL CHARACTERISTICS (CONTINUED)

Electrical Characteristics: All measurements at $T_J = +25^\circ\text{C}$ unless otherwise noted. **Bold** values are guaranteed across the operating temperature range.

Parameter	Min.	Typ.	Max.	Units	Conditions
Current Limit	5.0	6.5	—	A	$V_{OUT} = 0\text{V}$ (Note 3)
Output Noise Voltage	—	260	—	μV_{RMS}	$C_L = 47\ \mu\text{F}$, 10 Hz to 100 kHz, $I_L = 100\ \text{mA}$
Reference (MIC29512 Only)					
Reference Voltage	1.215	—	1.265	V_{MAX}	$10\ \text{mA} \leq I_O \leq I_{\text{FL}}$, $V_{OUT} + 1\text{V} \leq V_{IN} \leq 8\text{V}$ (Note 1)
Adjust Pin Bias Current	—	40	80	nA	—
	—	—	120		—
Reference Voltage Temperature Coefficient	—	20	—	ppm/ $^\circ\text{C}$	Note 6
Adjust Pin Bias Current Temperature Coefficient	—	0.1	—	nA/ $^\circ\text{C}$	—
Enable Input (MIC29512 Only)					
Input Logic Voltage	—	—	0.8	V	Low (off)
	2.4	—	—		High (on)
Enable (EN) Pin Current	—	29	75	μA	$V_{\text{EN}} = V_{\text{IN}}$
	—	—	4		$V_{\text{EN}} = 0.8\text{V}$
Regulator Output Current in Shutdown	—	10	20	μA	Note 7

- Note 1:** Full Load current is defined as 5A for the MIC29510/29512. For testing, V_{OUT} is programmed to 5V.
- Note 2:** Dropout voltage defined as the input-to-output differential when the output voltage drops to 99% of its nominal value with $V_{OUT} + 1\text{V}$ applied to V_{IN} .
- Note 3:** For this test, V_{IN} is the larger of 8V or $V_{OUT} + 3\text{V}$.
- Note 4:** Ground pin current is regulator quiescent current. Total current drawn from the source is the sum of the load current plus the ground pin current.
- Note 5:** Output voltage temperature coefficient is defined as the worst case voltage change divided by the total temperature range.
- Note 6:** $V_{\text{REF}} \leq V_{\text{OUT}} \leq (V_{\text{IN}} - 1\text{V})$, $2.4\text{V} \leq V_{\text{IN}} \leq 16\text{V}$, $10\ \text{mA} < I_L \leq I_{\text{FL}}$, $T_J \leq T_{J(\text{MAX})}$.
- Note 7:** $V_{\text{EN}} \leq 0.8\text{V}$ and $V_{\text{IN}} \leq 8\text{V}$, $V_{\text{OUT}} = 0$.

TEMPERATURE SPECIFICATIONS

Parameters	Sym.	Min.	Typ.	Max.	Units	Conditions
Temperature Ranges						
Operating Junction Temperature Range	T_J	0	—	+125	°C	Note 1
Storage Temperature Range	T_S	-65	—	+150	°C	—
Lead Temperature	—	—	—	+260	°C	Soldering, 5 sec.
Package Thermal Resistance						
Thermal Resistance, TO-220	θ_{JA}	—	55	—	°C/W	—
	θ_{JC}	—	2	—	°C/W	—

Note 1: The maximum allowable power dissipation is a function of ambient temperature, the maximum allowable junction temperature and the thermal resistance from junction to air (i.e., T_A , T_J , θ_{JA}). Exceeding the maximum allowable power dissipation will cause the device operating junction temperature to exceed the maximum +125°C rating. Sustained junction temperatures above +125°C can impact the device reliability.

MIC29510/12

2.0 TYPICAL PERFORMANCE CURVES

Note: The graphs and tables provided following this note are a statistical summary based on a limited number of samples and are provided for informational purposes only. The performance characteristics listed herein are not tested or guaranteed. In some graphs or tables, the data presented may be outside the specified operating range (e.g., outside specified power supply range) and therefore outside the warranted range.

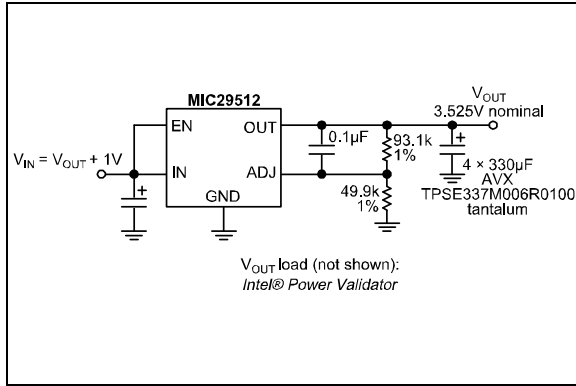

FIGURE 2-1: MIC29512 Load Transient Test Circuit.

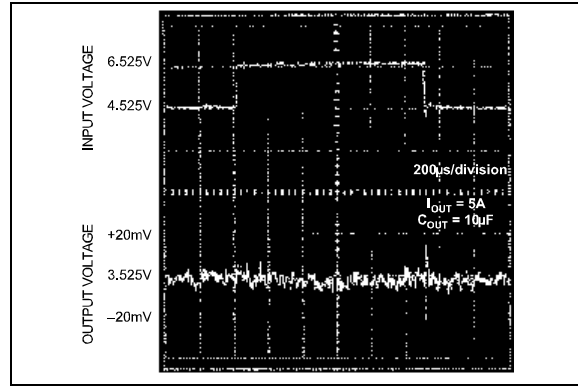

FIGURE 2-3: MIC29512 Line Transient Response: 5A Load, 10 µF Output Capacitance.

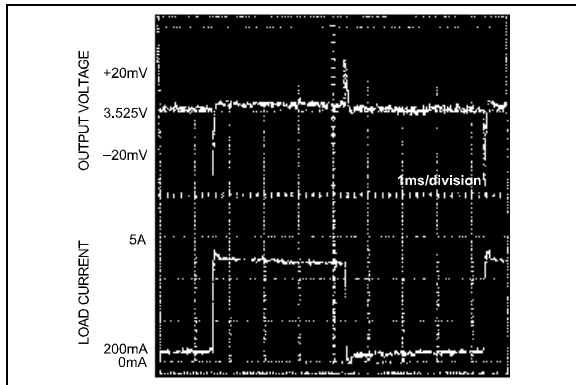

FIGURE 2-2: MIC29512 Load Transient Response (see Test Circuit Schematic).

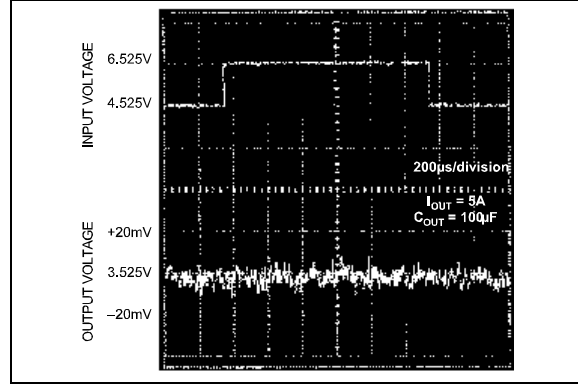

FIGURE 2-4: MIC29512 Line Transient Response: 5A Load, 100 µF Output Capacitance.

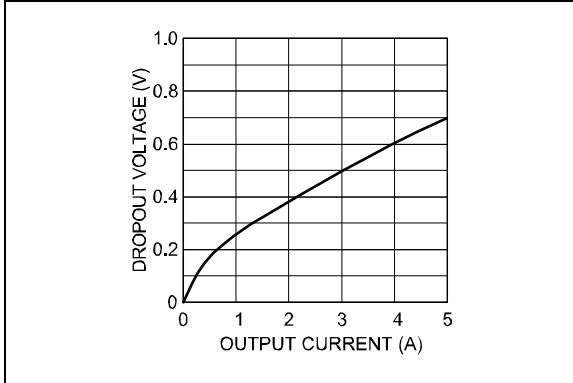

FIGURE 2-5: MIC2951x Dropout Voltage vs. Output Current.

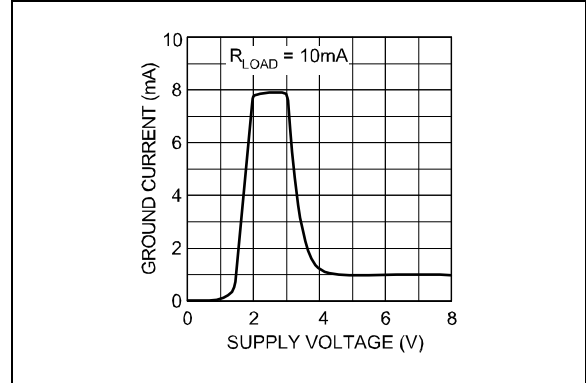

FIGURE 2-8: MIC2951x-3.3 Ground Current vs. Supply Voltage.

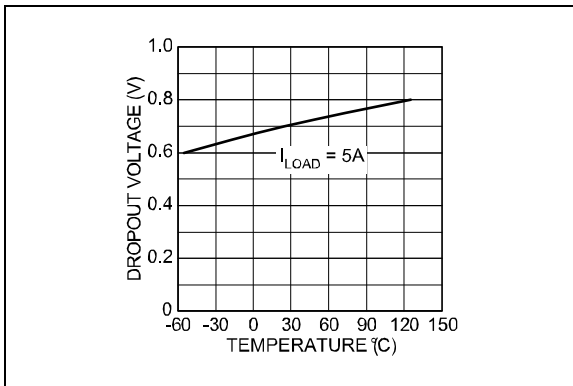

FIGURE 2-6: MIC2951x Dropout Voltage vs. Temperature.

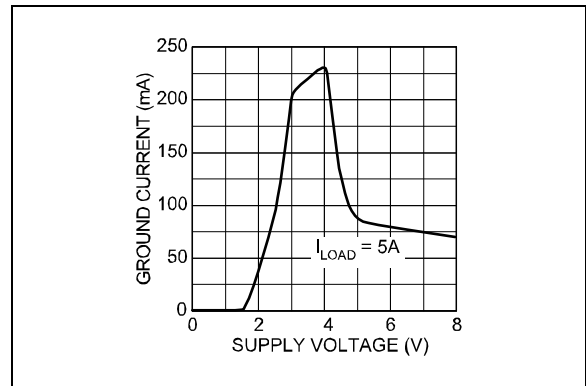

FIGURE 2-9: MIC2951x-3.3 Ground Current vs. Supply Voltage.

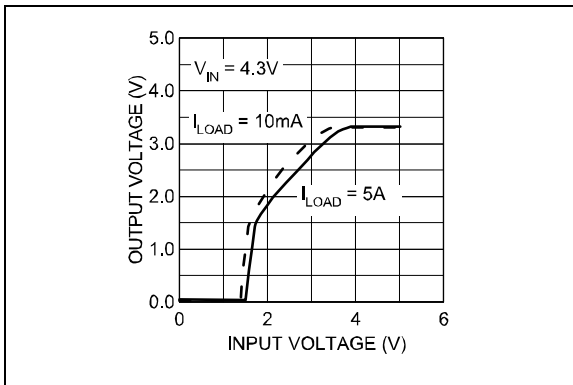

FIGURE 2-7: MIC29510-3.3 Dropout Characteristics.

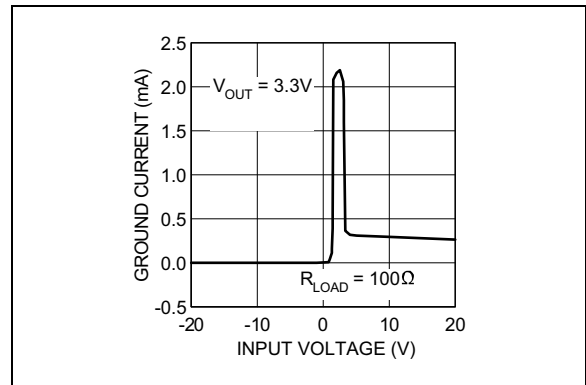

FIGURE 2-10: MIC2951x Ground Current vs. Input Voltage.

MIC29510/12

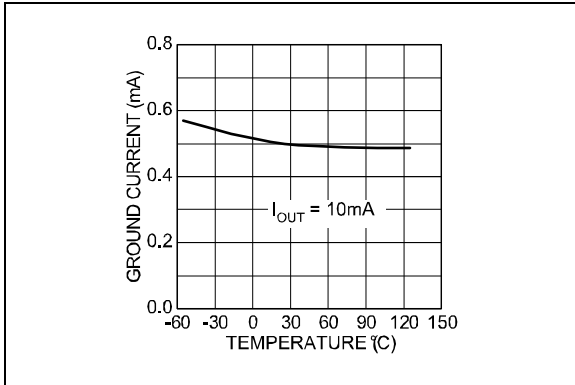

FIGURE 2-11: MIC2951x Ground Current vs. Temperature.

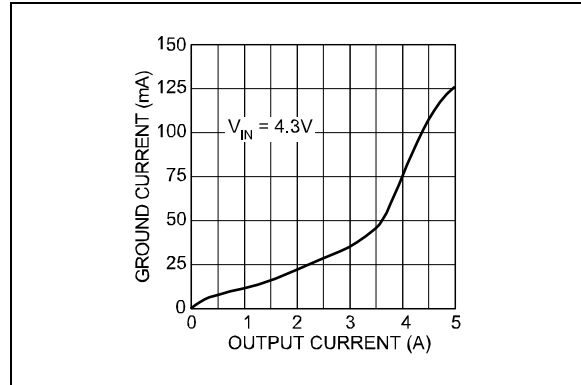

FIGURE 2-14: MIC2951x-3.3 Ground Current vs. Output Current.

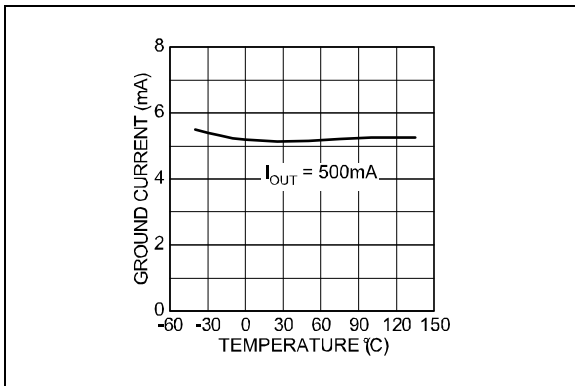

FIGURE 2-12: MIC2951x Ground Current vs. Temperature.

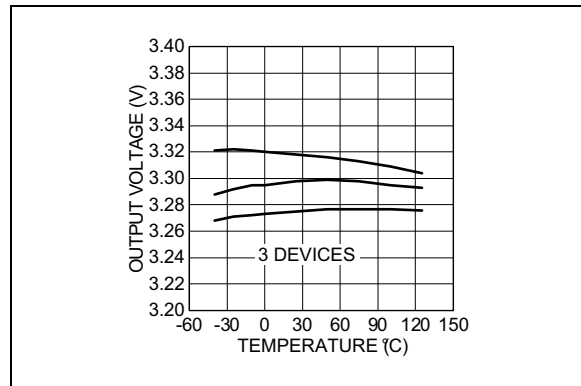

FIGURE 2-15: MIC29510-3.3 Output Voltage vs. Temperature.

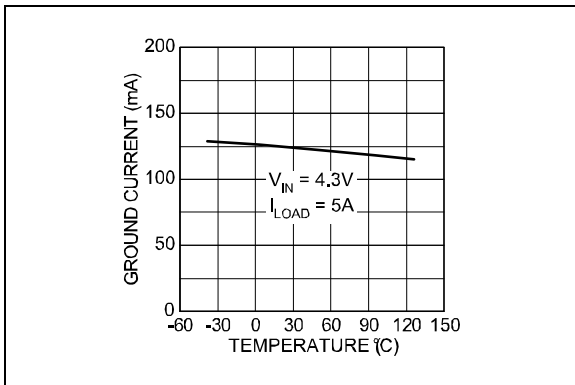

FIGURE 2-13: MIC2951x-3.3 Ground Current vs. Temperature.

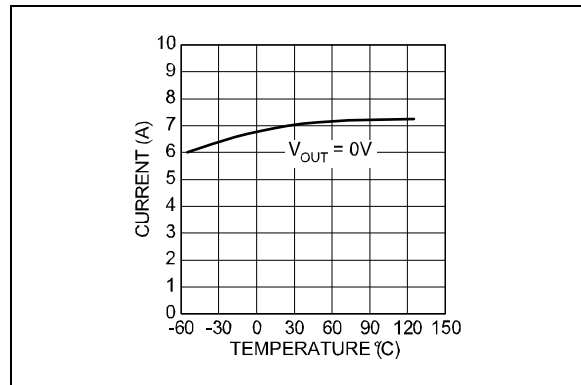

FIGURE 2-16: MIC2951x Short-Circuit Current vs. Temperature.

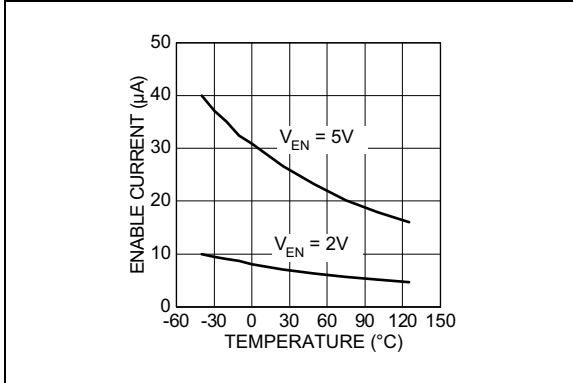

FIGURE 2-17: MIC29512 Enable Current vs. Temperature.

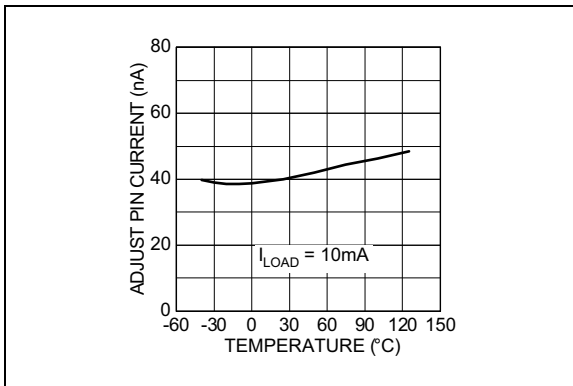

FIGURE 2-18: MIC29512 Adjust Pin Current vs. Temperature.

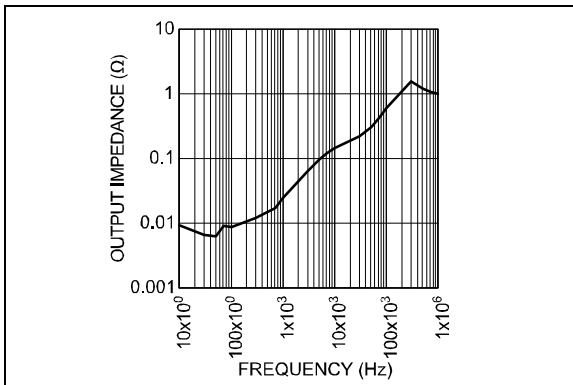

FIGURE 2-19: MIC2951x Output Impedance vs. Frequency.

MIC29510/12

3.0 PIN DESCRIPTIONS

The descriptions of the pins are listed in [Table 3-1](#).

TABLE 3-1: MIC29510 PIN FUNCTION TABLE

Pin Number	Pin Name	Description
1	IN	Unregulated input: +16V maximum supply.
2	GND	Ground: Internally connected to tab (ground).
3	OUT	Regulated output.

TABLE 3-2: MIC29512 PIN FUNCTION TABLE

Pin Number	Pin Name	Description
1	EN	Enable (input): Logic-level ON/OFF control.
2	IN	Unregulated input: +16V maximum supply.
3	GND	Ground: Internally connected to tab (ground).
4	OUT	Regulated output.
5	ADJ	Output voltage adjust: 1.24V feedback from external resistive divider.

4.0 APPLICATION INFORMATION

The MIC29510 and MIC29512 are high performance low-dropout voltage regulators suitable for all moderate to high-current voltage regulator applications. Their 600 mV of dropout voltage at full load make them especially valuable in battery-powered systems and as high efficiency noise filters in “post-regulator” applications. Unlike older NPN-pass transistor designs, where the minimum dropout voltage is limited by the base-emitter voltage drop and collector-emitter saturation voltage, dropout performance of the PNP output of these devices is limited merely by the low VCE saturation voltage.

A trade-off for the low dropout voltage is a varying base drive requirement. But Microchip’s Super β PNP process reduces this drive requirement to merely 2% to 5% of the load current.

MIC29510/12 regulators are fully protected from damage due to fault conditions. Current limiting is provided. This limiting is linear; output current under overload conditions is constant. Thermal shutdown disables the device when the die temperature exceeds the maximum safe operating temperature.

Transient protection allows device (and load) survival even when the input voltage spike above and below nominal. The output structure of these regulators allows voltages in excess of the desired output voltage to be applied without reverse current flow. The MIC29512 version offers a logic-level ON/OFF control: when disabled, the devices draw nearly zero current.

An additional feature of this regulator family is a common pinout: a design’s current requirement may change up or down yet use the same board layout, as all of Microchip’s high-current Super β PNP regulators have identical pinouts.

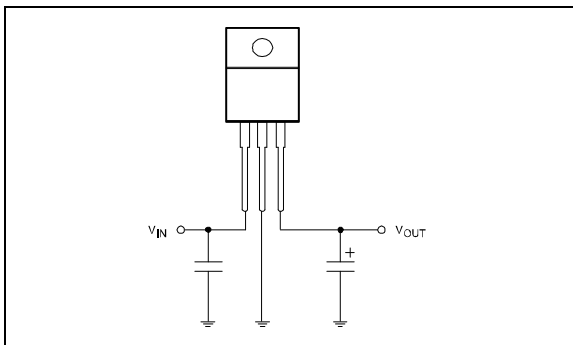

FIGURE 4-1: The MIC29510 Requires Only Two Capacitors for Operation.

4.1 Thermal Design

Linear regulators are simple to use. The most complicated design parameters to consider are thermal characteristics. Thermal design requires the following application-specific parameters:

- Maximum ambient temperature, T_A
- Output Current, I_{OUT}
- Output Voltage, V_{OUT}
- Input Voltage, V_{IN}

First, we calculate the power dissipation of the regulator from these numbers and the device parameters from this data sheet.

EQUATION 4-1:

$$P_D = I_{OUT} \times (1.02V_{IN} - V_{OUT})$$

The ground current is approximated by 3% of I_{OUT} , then the heat sink thermal resistance is determined by the following formula:

EQUATION 4-2:

$$\theta_{SA} = \frac{T_{J(MAX)} - T_A}{P_D} - (\theta_{JC} + \theta_{CS})$$

Where:

$T_{J(MAX)}$ = Less than or equal to +125°C.

θ_{CS} = Between 0°C/W and 2°C/W.

The heat sink may be significantly reduced in applications where the minimum input voltage is known and is large compared with the dropout voltage. Use a series input resistor to drop excessive voltage and distribute the heat between this resistor and the regulator. The low dropout properties of the Super β PNP regulators allow very significant reductions in regulator power dissipation and the associated heat sink without compromising performance. When this technique is employed, a capacitor of at least 0.1 μ F is needed directly between the input and regulator ground.

Please refer to [Application Note 9](#) for further details and examples on thermal design and heat sink specification.

MIC29510/12

4.2 Capacitor Requirements

For stability and minimum output noise, a capacitor on the regulator output is necessary. The value of this capacitor is dependent upon the output current; lower currents allow smaller capacitors. MIC29510/2 regulators are stable with a minimum capacitor value of 47 μF at full load.

This capacitor need not be an expensive low ESR type: aluminum electrolytics are adequate. In fact, extremely low ESR capacitors may contribute to instability. Tantalum capacitors are recommended for systems where fast load transient response is important.

Where the regulator is powered from a source with high AC impedance, a 0.1 μF capacitor connected between Input and GND is recommended. This capacitor should have good characteristics to above 250 kHz.

4.3 Transient Response and 5V to 3.3V Conversion

The MIC29510/2 have excellent response to variations in input voltage and load current. By virtue of their low dropout voltage, these devices do not saturate into dropout as readily as similar NPN-based designs. A 3.3V output Microchip LDO will maintain full speed and performance with an input supply as low as 4.2V, and will still provide some regulation with supplies down to 3.8V, unlike NPN devices that require 5.1V or more for good performance and become nothing more than a resistor under 4.6V of input. Microchip's PNP regulators provide superior performance in "5V to 3.3V" conversion applications, especially when all tolerances are considered.

4.4 Adjustable Regulator Design

The adjustable regulator version, MIC29512, allows programming the output voltage anywhere between 1.25V and the 16V maximum operating rating of the family. Two resistors are used. Resistors can be quite large, up to 100 k Ω , because of the very high input impedance and low bias current of the sense comparator. The resistor values are calculated using the following equation in which V_{OUT} is the desired output voltage.

EQUATION 4-3:

$$R1 = R2 \times \left(\frac{V_{OUT}}{1.24} - 1 \right)$$

4.5 Adjustable Regulator Design.

Figure 4-2 shows component definition for the MIC29512.

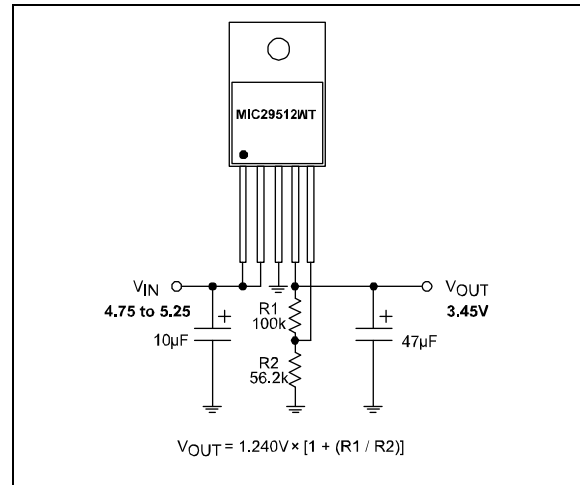

FIGURE 4-2: Adjustable Regulator with Resistors.

4.6 Enable Input

The MIC29512 version features an enable (EN) input that allows ON/OFF control of the device. Special design allows "zero" current drain when the device is disabled—only microamperes of leakage current flows. The EN input has TTL/CMOS-compatible thresholds for simple interfacing with logic, or may be directly tied to V_{IN} . Enabling the regulator requires approximately 20 μA of current into the EN pin.

TABLE 4-1: RESISTOR VALUES FOR MIC29512

Voltage	Standard Values	
	R1	R2
2.85V	100 k Ω	76.8 k Ω
2.9V	100 k Ω	75.0 k Ω
3.0V	100 k Ω	69.8 k Ω
3.1V	100 k Ω	66.5 k Ω
3.15V	100 k Ω	64.9 k Ω
3.3V	100 k Ω	60.4 k Ω
3.45V	100 k Ω	56.2 k Ω
3.525V	93.1 k Ω	51.1 k Ω
3.6V	100 k Ω	52.3 k Ω
3.8V	100 k Ω	48.7 k Ω
4.0V	100 k Ω	45.3 k Ω
4.1V	100 k Ω	43.2 k Ω

5.0 PACKAGING INFORMATION

5.1 Package Marking Information

3-Lead TO-220*

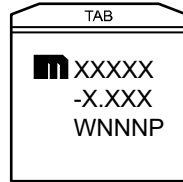

Example

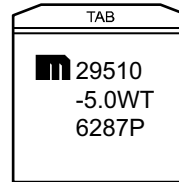

5-Lead TO-220*



Example

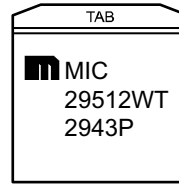

Legend:	XX...X	Product code or customer-specific information
	Y	Year code (last digit of calendar year)
	YY	Year code (last 2 digits of calendar year)
	WW	Week code (week of January 1 is week '01')
	NNN	Alphanumeric traceability code
	(e3)	Pb-free JEDEC® designator for Matte Tin (Sn)
	*	This package is Pb-free. The Pb-free JEDEC designator (e3) can be found on the outer packaging for this package.
	•, ▲, ▼	Pin one index is identified by a dot, delta up, or delta down (triangle mark).
Note:	In the event the full Microchip part number cannot be marked on one line, it will be carried over to the next line, thus limiting the number of available characters for customer-specific information. Package may or may not include the corporate logo.	
	Underbar () and/or Overbar () symbol may not be to scale.	

MIC29510/12

3-Lead TO-220 Package Outline and Recommended Land Pattern

TITLE

3 LEAD TO220 PACKAGE OUTLINE & RECOMMENDED LAND PATTERN

DRAWING #	TO220-3LD-PL-1	UNIT	INCH
Lead Frame	Copper Alloy	Lead Finish	Matte Tin

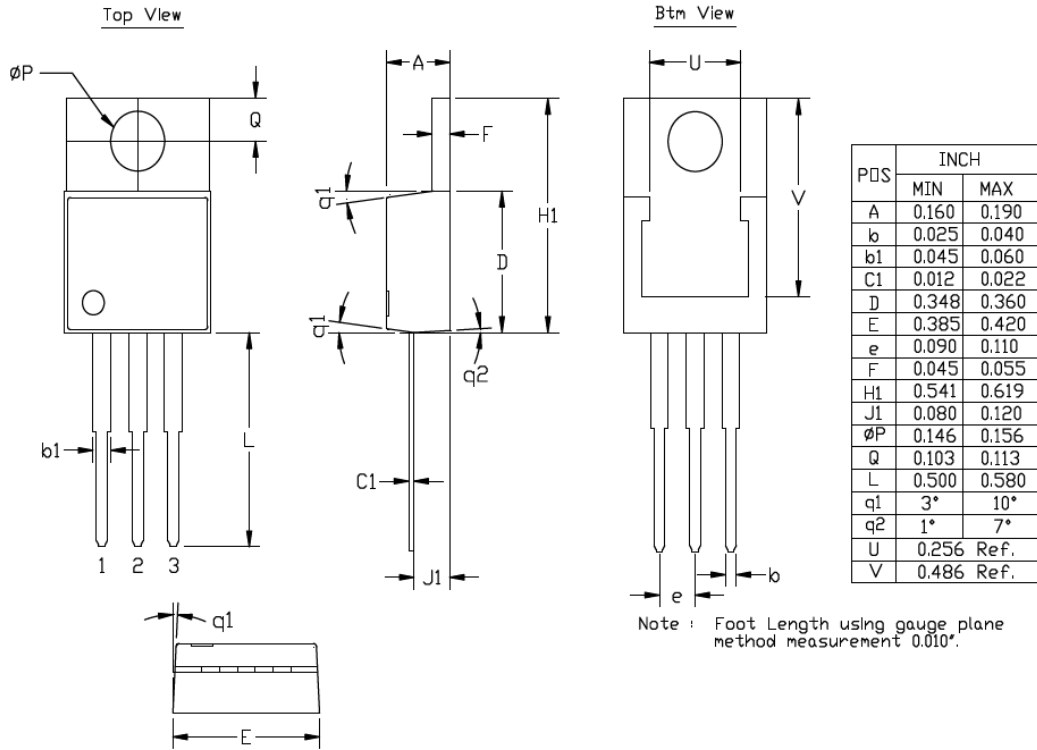

Note: For the most current package drawings, please see the Microchip Packaging Specification located at <http://www.microchip.com/packaging>.

5-Lead TO-220 Package Outline and Recommended Land Pattern

5-Lead Transistor Outline Type LB03 (B8X) - [TO-220] Micrel Legacy Package TO220-LB03-5LD-PL-1

Note: For the most current package drawings, please see the Microchip Packaging Specification located at <http://www.microchip.com/packaging>

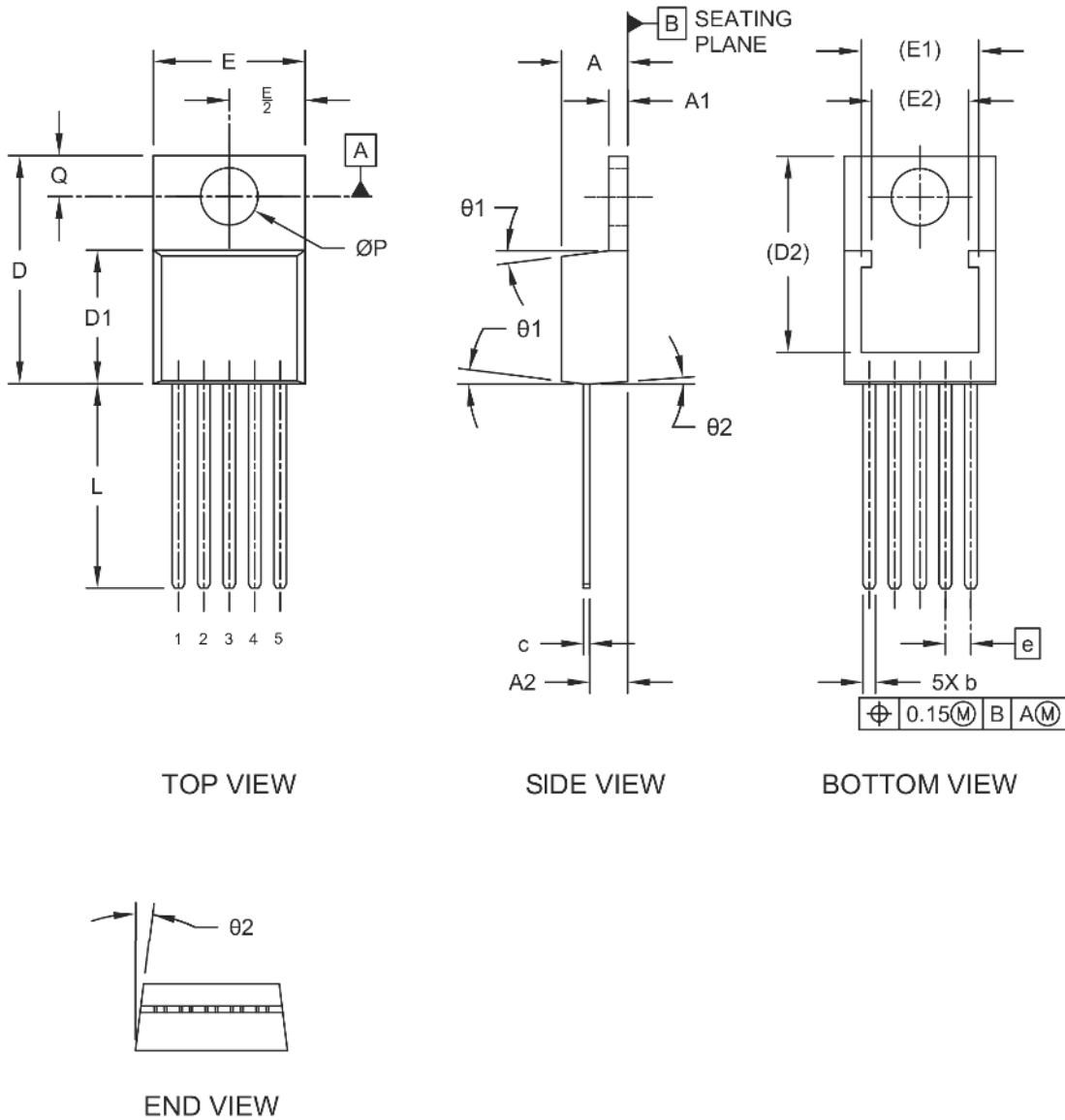

Microchip Technology Drawing C04-036 Rev D Sheet 1 of 2

MIC29510/12

5-Lead Transistor Outline Type LB03 (B8X) - [TO-220] Micrel Legacy Package TO220-LB03-5LD-PL-1

Note: For the most current package drawings, please see the Microchip Packaging Specification located at <http://www.microchip.com/packaging>

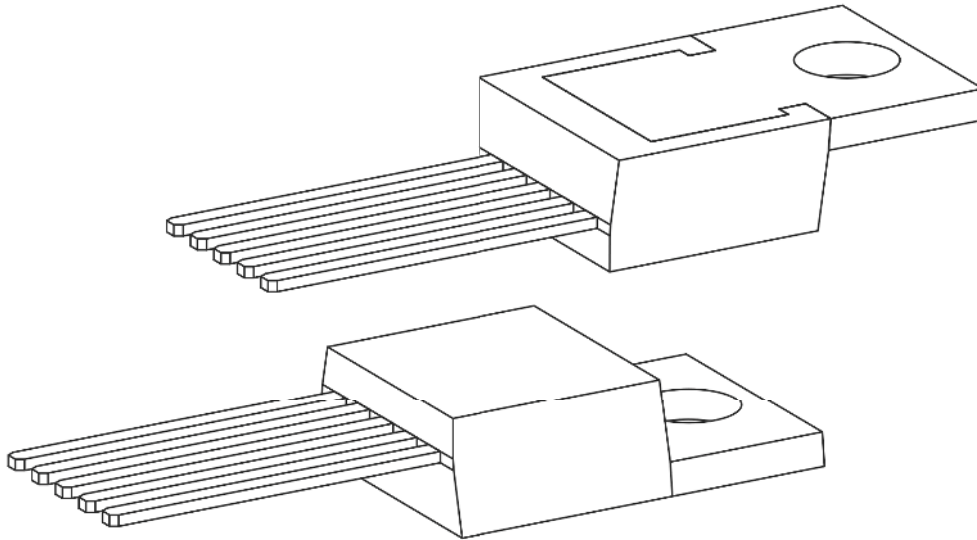

Dimension Limits		INCHES		
		Min	Nom	Max
Number of Leads	N	5		
Pitch	e	.067 BSC		
Overall Height	A	.160	.175	.190
Tab Height	A1	.045	.050	.055
Seating Plane to Lead	A2	.080	.098	.115
Lead Width	b	.025	.033	.040
Lead Thickness	c	.012	.016	.020
Lead Length	L	.500	.540	.580
Total Body Length Including Tab	D	.542	.580	.619
Molded Body Length	D1	.348	.354	.360
Total Width	E	.380	.400	.420
Pad Width	E1	0.256 REF		
Pad Length	D2	0.486 REF		
Hole Diameter	ØP	.146	.151	.156
Hole Center to Tab Edge	Q	.103	.108	.113
Molded Body Draft Angle	Ø1	3	7	10
Molded Body Draft Angle	Ø2	1	4	7

Notes:

- Pin 1 visual index feature may vary, but must be located within the hatched area.
- Dimensioning and tolerancing per ASME Y14.5M
BSC: Basic Dimension. Theoretically exact value shown without tolerances.
REF: Reference Dimension, usually without tolerance, for information purposes only.

Microchip Technology Drawing C04-036 Rev D Sheet 2 of 2

APPENDIX A: REVISION HISTORY

Revision A (November 2020)

- Converted Micrel document MIC29510/12 to Microchip data sheet template DS20006451A.
- Minor grammatical text changes throughout.

MIC29510/12

NOTES:

PRODUCT IDENTIFICATION SYSTEM

To order or obtain information, e.g., on pricing or delivery, contact your local Microchip representative or sales office.

<u>Device</u>	<u>-X.X</u>	<u>X</u>	<u>XX</u>	<u>-XX</u>
Part No.	Output Voltage	Temp. Range	Package	Media Type
Device:	MIC29510:	5A Fast-Response LDO Regulator		
	MIC29512:	5A Fast-Response LDO Regulator		
Output Voltage:	3.3 =	3.3V (MIC29510 Only)		
	5.0 =	5.0V (MIC29510 Only)		
	<blank>=	Adjustable (MIC29512 Only)		
Temperature Range:	W =	0°C to +125°C		
Package:	T =	3-Lead TO-220 (MIC29510)		
	T =	5-Lead TO-220 (MIC29512)		
Media Type:	<blank>=	50/Tube		

Examples:	
a) MIC29510-3.3WT:	MIC29510, 3.3V Output Voltage, 0°C to +125°C, 3-Lead TO-220, 50/Tube
b) MIC29510-5.0WT:	MIC29510, 5.0V Output Voltage, 0°C to +125°C, 3-Lead TO-220, 50/Tube
c) MIC29512WT:	MIC29512, Adj. Output Voltage, 0°C to +125°C, 5-Lead TO-220, 50/Tube

Note 1: Tape and Reel identifier only appears in the catalog part number description. This identifier is used for ordering purposes and is not printed on the device package. Check with your Microchip Sales Office for package availability with the Tape and Reel option.

MIC29510/12

NOTES:

Note the following details of the code protection feature on Microchip devices:

- Microchip products meet the specifications contained in their particular Microchip Data Sheet.
- Microchip believes that its family of products is secure when used in the intended manner and under normal conditions.
- There are dishonest and possibly illegal methods being used in attempts to breach the code protection features of the Microchip devices. We believe that these methods require using the Microchip products in a manner outside the operating specifications contained in Microchip's Data Sheets. Attempts to breach these code protection features, most likely, cannot be accomplished without violating Microchip's intellectual property rights.
- Microchip is willing to work with any customer who is concerned about the integrity of its code.
- Neither Microchip nor any other semiconductor manufacturer can guarantee the security of its code. Code protection does not mean that we are guaranteeing the product is "unbreakable." Code protection is constantly evolving. We at Microchip are committed to continuously improving the code protection features of our products. Attempts to break Microchip's code protection feature may be a violation of the Digital Millennium Copyright Act. If such acts allow unauthorized access to your software or other copyrighted work, you may have a right to sue for relief under that Act.

Information contained in this publication is provided for the sole purpose of designing with and using Microchip products. Information regarding device applications and the like is provided only for your convenience and may be superseded by updates. It is your responsibility to ensure that your application meets with your specifications.

THIS INFORMATION IS PROVIDED BY MICROCHIP "AS IS". MICROCHIP MAKES NO REPRESENTATIONS OR WARRANTIES OF ANY KIND WHETHER EXPRESS OR IMPLIED, WRITTEN OR ORAL, STATUTORY OR OTHERWISE, RELATED TO THE INFORMATION INCLUDING BUT NOT LIMITED TO ANY IMPLIED WARRANTIES OF NON-INFRINGEMENT, MERCHANTABILITY, AND FITNESS FOR A PARTICULAR PURPOSE OR WARRANTIES RELATED TO ITS CONDITION, QUALITY, OR PERFORMANCE.

IN NO EVENT WILL MICROCHIP BE LIABLE FOR ANY INDIRECT, SPECIAL, PUNITIVE, INCIDENTAL OR CONSEQUENTIAL LOSS, DAMAGE, COST OR EXPENSE OF ANY KIND WHATSOEVER RELATED TO THE INFORMATION OR ITS USE, HOWEVER CAUSED, EVEN IF MICROCHIP HAS BEEN ADVISED OF THE POSSIBILITY OR THE DAMAGES ARE FORESEEABLE. TO THE FULLEST EXTENT ALLOWED BY LAW, MICROCHIP'S TOTAL LIABILITY ON ALL CLAIMS IN ANY WAY RELATED TO THE INFORMATION OR ITS USE WILL NOT EXCEED THE AMOUNT OF FEES, IF ANY, THAT YOU HAVE PAID DIRECTLY TO MICROCHIP FOR THE INFORMATION. Use of Microchip devices in life support and/or safety applications is entirely at the buyer's risk, and the buyer agrees to defend, indemnify and hold harmless Microchip from any and all damages, claims, suits, or expenses resulting from such use. No licenses are conveyed, implicitly or otherwise, under any Microchip intellectual property rights unless otherwise stated.

Trademarks

The Microchip name and logo, the Microchip logo, Adaptec, AnyRate, AVR, AVR logo, AVR Freaks, BesTime, BitCloud, chipKIT, chipKIT logo, CryptoMemory, CryptoRF, dsPIC, FlashFlex, flexPWR, HELDO, IGL00, JukeBlox, KeeLoq, Kleer, LANCheck, LinkMD, maXStylus, maXTouch, MediaLB, megaAVR, Microsemi, Microsemi logo, MOST, MOST logo, MPLAB, OptoLyzer, PackeTime, PIC, picoPower, PICSTART, PIC32 logo, PolarFire, Prochip Designer, QTouch, SAM-BA, SenGenuity, SpyNIC, SST, SST Logo, SuperFlash, Symmetricom, SyncServer, Tachyon, TimeSource, tinyAVR, UNI/O, Vectron, and XMEGA are registered trademarks of Microchip Technology Incorporated in the U.S.A. and other countries.

AgileSwitch, APT, ClockWorks, The Embedded Control Solutions Company, EtherSynch, FlashTec, Hyper Speed Control, HyperLight Load, IntelliMOS, Libero, motorBench, mTouch, Powermite 3, Precision Edge, ProASIC, ProASIC Plus, ProASIC Plus logo, Quiet-Wire, SmartFusion, SyncWorld, Temux, TimeCesium, TimeHub, TimePictra, TimeProvider, WinPath, and ZL are registered trademarks of Microchip Technology Incorporated in the U.S.A.

Adjacent Key Suppression, AKS, Analog-for-the-Digital Age, Any Capacitor, AnyIn, AnyOut, Augmented Switching, BlueSky, BodyCom, CodeGuard, CryptoAuthentication, CryptoAutomotive, CryptoCompanion, CryptoController, dsPICDEM, dsPICDEM.net, Dynamic Average Matching, DAM, ECAN, Espresso T1S, EtherGREEN, IdealBridge, In-Circuit Serial Programming, ICSP, INICnet, Intelligent Paralleling, Inter-Chip Connectivity, JitterBlocker, maxCrypto, maxView, memBrain, Mindi, MiWi, MPASM, MPF, MPLAB Certified logo, MPLIB, MPLINK, MultiTRAK, NetDetach, Omniscient Code Generation, PICDEM, PICDEM.net, PICkit, PICtail, PowerSmart, PureSilicon, QMatrix, REAL ICE, Ripple Blocker, RTAX, RTG4, SAM-ICE, Serial Quad I/O, simpleMAP, SimpliPHY, SmartBuffer, SMART-I.S., storClad, SQI, SuperSwitcher, SuperSwitcher II, Switchtec, SynchroPHY, Total Endurance, TSHARC, USBCheck, VariSense, VectorBlox, VeriPHY, ViewSpan, WiperLock, XpressConnect, and ZENA are trademarks of Microchip Technology Incorporated in the U.S.A. and other countries.

SQTP is a service mark of Microchip Technology Incorporated in the U.S.A.

The Adaptec logo, Frequency on Demand, Silicon Storage Technology, and Symmcom are registered trademarks of Microchip Technology Inc. in other countries.

GestIC is a registered trademark of Microchip Technology Germany II GmbH & Co. KG, a subsidiary of Microchip Technology Inc., in other countries.

All other trademarks mentioned herein are property of their respective companies.

© 2020, Microchip Technology Incorporated, All Rights Reserved.

ISBN: 978-1-5224-7144-8

For information regarding Microchip's Quality Management Systems, please visit www.microchip.com/quality.



MICROCHIP

Worldwide Sales and Service

AMERICAS

Corporate Office
2355 West Chandler Blvd.
Chandler, AZ 85224-6199
Tel: 480-792-7200
Fax: 480-792-7277
Technical Support:
<http://www.microchip.com/support>
Web Address:
www.microchip.com

Atlanta

Duluth, GA
Tel: 678-957-9614
Fax: 678-957-1455

Austin, TX

Tel: 512-257-3370

Boston

Westborough, MA
Tel: 774-760-0087
Fax: 774-760-0088

Chicago

Itasca, IL
Tel: 630-285-0071
Fax: 630-285-0075

Dallas

Addison, TX
Tel: 972-818-7423
Fax: 972-818-2924

Detroit

Novi, MI
Tel: 248-848-4000

Houston, TX

Tel: 281-894-5983

Indianapolis

Noblesville, IN
Tel: 317-773-8323
Fax: 317-773-5453
Tel: 317-536-2380

Los Angeles

Mission Viejo, CA
Tel: 949-462-9523
Fax: 949-462-9608
Tel: 951-273-7800

Raleigh, NC

Tel: 919-844-7510

New York, NY

Tel: 631-435-6000

San Jose, CA

Tel: 408-735-9110
Tel: 408-436-4270

Canada - Toronto

Tel: 905-695-1980
Fax: 905-695-2078

ASIA/PACIFIC

Australia - Sydney
Tel: 61-2-9868-6733

China - Beijing
Tel: 86-10-8569-7000

China - Chengdu
Tel: 86-28-8665-5511

China - Chongqing
Tel: 86-23-8980-9588

China - Dongguan
Tel: 86-769-8702-9880

China - Guangzhou
Tel: 86-20-8755-8029

China - Hangzhou
Tel: 86-571-8792-8115

China - Hong Kong SAR
Tel: 852-2943-5100

China - Nanjing
Tel: 86-25-8473-2460

China - Qingdao
Tel: 86-532-8502-7355

China - Shanghai
Tel: 86-21-3326-8000

China - Shenyang
Tel: 86-24-2334-2829

China - Shenzhen
Tel: 86-755-8864-2200

China - Suzhou
Tel: 86-186-6233-1526

China - Wuhan
Tel: 86-27-5980-5300

China - Xian
Tel: 86-29-8833-7252

China - Xiamen
Tel: 86-592-2388138

China - Zhuhai
Tel: 86-756-3210040

ASIA/PACIFIC

India - Bangalore
Tel: 91-80-3090-4444

India - New Delhi
Tel: 91-11-4160-8631

India - Pune
Tel: 91-20-4121-0141

Japan - Osaka
Tel: 81-6-6152-7160

Japan - Tokyo
Tel: 81-3-6880-3770

Korea - Daegu
Tel: 82-53-744-4301

Korea - Seoul
Tel: 82-2-554-7200

Malaysia - Kuala Lumpur
Tel: 60-3-7651-7906

Malaysia - Penang
Tel: 60-4-227-8870

Philippines - Manila
Tel: 63-2-634-9065

Singapore
Tel: 65-6334-8870

Taiwan - Hsin Chu
Tel: 886-3-577-8366

Taiwan - Kaohsiung
Tel: 886-7-213-7830

Taiwan - Taipei
Tel: 886-2-2508-8600

Thailand - Bangkok
Tel: 66-2-694-1351

Vietnam - Ho Chi Minh
Tel: 84-28-5448-2100

EUROPE

Austria - Wels
Tel: 43-7242-2244-39
Fax: 43-7242-2244-393

Denmark - Copenhagen
Tel: 45-4485-5910
Fax: 45-4485-2829

Finland - Espoo
Tel: 358-9-4520-820

France - Paris
Tel: 33-1-69-53-63-20
Fax: 33-1-69-30-90-79

Germany - Garching
Tel: 49-8931-9700

Germany - Haan
Tel: 49-2129-3766400

Germany - Heilbronn
Tel: 49-7131-72400

Germany - Karlsruhe
Tel: 49-721-625370

Germany - Munich
Tel: 49-89-627-144-0
Fax: 49-89-627-144-44

Germany - Rosenheim
Tel: 49-8031-354-560

Israel - Ra'anana
Tel: 972-9-744-7705

Italy - Milan
Tel: 39-0331-742611
Fax: 39-0331-466781

Italy - Padova
Tel: 39-049-7625286

Netherlands - Drunen
Tel: 31-416-690399
Fax: 31-416-690340

Norway - Trondheim
Tel: 47-7288-4388

Poland - Warsaw
Tel: 48-22-3325737

Romania - Bucharest
Tel: 40-21-407-87-50

Spain - Madrid
Tel: 34-91-708-08-90
Fax: 34-91-708-08-91

Sweden - Gothenberg
Tel: 46-31-704-60-40

Sweden - Stockholm
Tel: 46-8-5090-4654

UK - Wokingham
Tel: 44-118-921-5800
Fax: 44-118-921-5820