

Charge Pump Controller with Automatic Mode Transition

General Description

The RT9397BF is a highly integrated step-up charge pump and inverting charge pump to generate positive and negative output voltage. The output voltages can be adjusted from $\pm 4.5V$ to $\pm 6V$ through external feedback resistors.

The part maintains highest efficiency by utilizing a x1.33/x1.5/x1.75/x2 mode fractional charge pump with automatic mode transition.

The RT9397BF is available in a WQFN-20L 3x3 package to achieve optimized solution for PCB space.

Applications

- TFT-LCD Smart Phone Display

Ordering Information

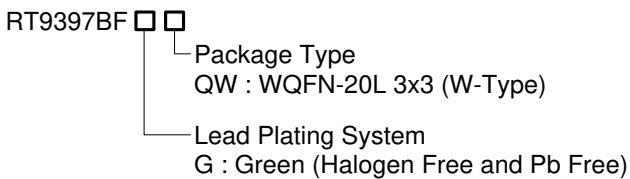

Note :

Richtek products are :

- ▶ RoHS compliant and compatible with the current requirements of IPC/JEDEC J-STD-020.
- ▶ Suitable for use in SnPb or Pb-free soldering processes.

Features

- 2.7V to 4.5V Supply Voltage Range
- Over 80% Average Efficiency of Battery Life
- Support up to 50mA Output Current
- Low 1 μ A Shutdown Current
- Internal Soft-start Function
- Short Circuit Protection Function
- Over-Voltage Protection Function
- Over-Temperature Protection Function
- Charge Pump Controller with Automatic Mode Transition
- Adaptive x1.33/x1.5/x1.75/x2 Charge Pump Mode Transition for Positive Voltage and x-1 for Negative Voltage
- Low Input Noise and EMI
- Output with Fast Discharge when IC shutdown
- Adjustable Output Voltage Through External Feedback Resistor
- Available in 20-Lead WQFN Package

Marking Information

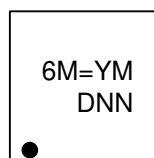

6M= : Product Code
YMDNN : Date Code

Simplified Application Circuit

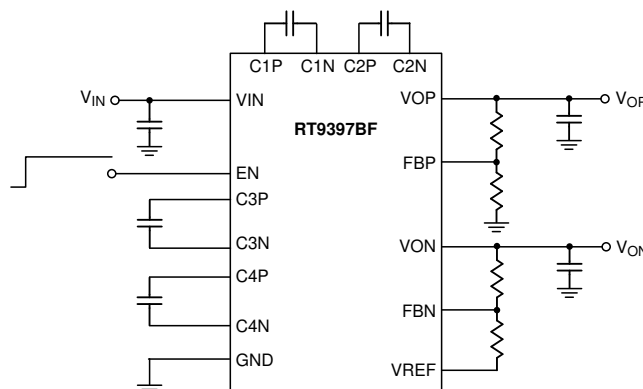

Pin Configurations

(TOP VIEW)

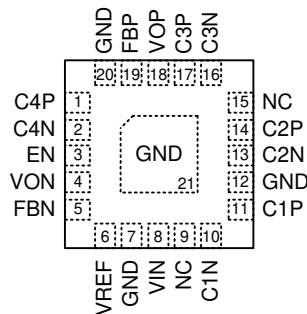

WQFN-20L 3x3

Functional Pin Description

Pin No.	Pin Name	Pin Function
1	C4P	Fly Capacitor 4 Positive Connection.
2	C4N	Fly Capacitor 4 Negative Connection.
3	EN	Enable Pin.
4	VON	Negative Terminal Output.
5	FBN	Feedback Voltage Input of VON.
6	VREF	Reference Voltage.
7, 12, 20, 21 (Exposed Pad)	GND	Ground. The exposed pad must be soldered to a large PCB and connected to GND for maximum thermal dissipation.
8	VIN	Power Input.
9	NC	Not Connected.
10	C1N	Fly Capacitor 1 Negative Connection.
11	C1P	Fly Capacitor 1 Positive Connection.
13	C2N	Fly Capacitor 2 Negative Connection.
14	C2P	Fly Capacitor 2 Positive Connection.
15	NC	No Internal Connection.
16	C3N	Fly Capacitor 3 Negative Connection.
17	C3P	Fly Capacitor 3 Positive Connection.
18	VOP	Positive Terminal Output.
19	FBP	Feedback Voltage Input of VOP.

Function Block Diagram

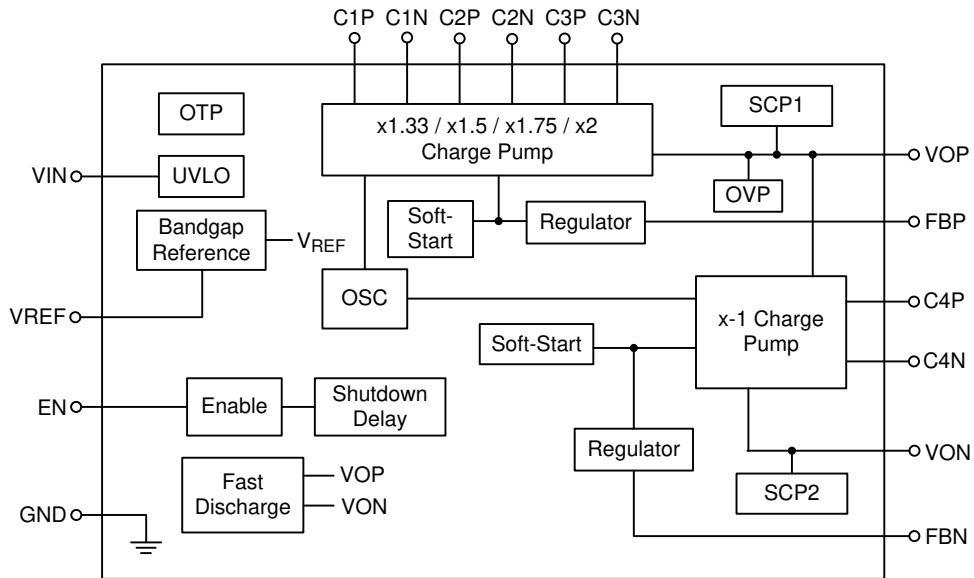

Operation

The RT9397BF is a highly integrated step-up charge pump and inverting charge pump to generate positive and negative output voltages. It can support input voltage range from 2.7V to 4.5V and the output current up to 50mA. Both positive and negative output voltages can be programmed by external feedback resistors. The RT9397BF equips different kinds of operating

modes to achieve high efficiency. It also provides Over-Temperature Protection (OTP), Over-Voltage Protection (OVP) and Short Circuit Protection (SCP) mechanisms to prevent the device from damage with abnormal operations. When the EN voltage is logic low for more than 300us, the IC will be shut down with low input supply current less than 1µA.

Absolute Maximum Ratings (Note1)

- Supply Voltage, V_{IN} ----- -0.3V to 6V
- Output Voltage, V_{OP} ----- -0.3V to 7V
- Output Voltage, V_{ON} ----- -7V to 0.3V
- Other Pins to GND ----- -0.3V to 6V
- Power Dissipation, P_D @ $T_A = 25^\circ\text{C}$
- WQFN-20L 3x3 ----- 3.33W
- Package Thermal Resistance (Note 2)
- WQFN-20L 3x3, θ_{JA} ----- 30°C/W
- WQFN-20L 3x3, θ_{JC} ----- 7.5°C/W
- Lead Temperature (Soldering, 10 sec.) ----- 260°C
- Junction Temperature ----- 150°C
- Storage Temperature Range ----- -65°C to 150°C
- ESD Susceptibility (Note 3)
- HBM (Human Body Model) ----- 2kV
- MM (Machine Model) ----- 200V

Recommended Operating Conditions (Note 4)

- Output Voltage, V_{OP} ----- -0.3V to 6V
- Output Voltage, V_{ON} ----- -6V to 0.3V
- Junction Temperature Range ----- -40°C to 125°C
- Ambient Temperature Range ----- -40°C to 85°C

Electrical Characteristics

($V_{IN} = 3.7\text{V}$, $C_{IN} = 4.7\mu\text{F}$, $C_{OP} = C_{ON} = 4.7\mu\text{F}$, C_{F1} to $C_{F3} = 1\mu\text{F}$, $C_{F4} = 4.7\mu\text{F}$, $T_A = 25^\circ\text{C}$, unless otherwise specified)

Parameter	Symbol	Test Conditions	Min	Typ	Max	Unit
General						
Input Voltage Range	V_{IN}		2.7	--	4.5	V
Under Voltage Lockout Threshold Voltage	V_{UVLO}		1.7	2	2.7	V
Under Voltage Lockout Hysteresis Voltage	V_{HYS}		--	100	--	mV
Switching Frequency	f_{SW}		--	250	--	kHz
V_{IN} Shutdown Current	I_{SHDN}	$EN = 0\text{V}$	--	--	1	μA
System Efficiency 1	η_1	$V_{IN} = 3.7\text{V}(\times 1.5 \text{ mode}),$ $I_{OP} = I_{ON} = 30\text{mA}, V_{OP}/V_{ON} = \pm 5\text{V}$	--	87	--	%
System Efficiency 2	η_2	$V_{IN} = 3.7\text{V}(\times 1.5 \text{ mode}),$ $I_{OP} = I_{ON} = 50\text{mA}, V_{OP}/V_{ON} = \pm 5\text{V}$	--	87	--	%
Reference Voltage	V_{REF}		--	1	--	V

Parameter	Symbol	Test Conditions	Min	Typ	Max	Unit
Charge Pump Switching Frequency						
Switching Frequency	f _{SWC}		--	250	--	kHz
Duty Cycle	D _{max}		--	50	--	%
Output Voltage						
Adjusted Positive Output Voltage	V _{OP}	V _{IN} = 2.9V to 4.35V, I _{OP} = I _{ON} = 1mA to 50mA	4.5	5	6	V
Feedback Voltage of VOP	V _{FBP}	V _{IN} = 2.9V to 4.35V, I _{OP} = I _{ON} = 1mA to 50mA	--	1	--	V
Adjusted Negative Output Voltage	V _{ON}	V _{IN} = 2.9V to 4.35V, I _{OP} = I _{ON} = 1mA to 50mA	-6	-5	-4.5	V
Feedback Voltage of VON	V _{FBN}	V _{IN} = 2.9V to 4.35V, I _{OP} = I _{ON} = 1mA to 50mA	--	0	--	V
Maximum VOP Output Current	I _{OP_MAX}	V _{IN} = 2.9V to 4.35V	50	--	--	mA
Maximum VON Output Current	I _{ON_MAX}	V _{IN} = 2.9V to 4.35V	50	--	--	mA
Protection						
VOP Soft-Start Time	T _{SSP}	No Load	--	2	--	ms
VON Soft-Start Time	T _{SSN}	No Load	--	2	--	ms
Soft-Start Inrush Current 1	I _{SS1}	(Note 5)	--	400	--	mA
Soft-Start Inrush Current 2	I _{SS2}	(Note 5)	--	400	--	mA
Over-Temperature Protection	T _{OTP}	(Note 5)	--	135	--	°C
Over-Temperature Protection Hysteresis	T _{OTP_HYST}	(Note 5)	--	10	--	°C
VOP Fast Discharge Resistance	R _{Dis1}		--	80	--	Ω
VON Fast Discharge Resistance	R _{Dis2}		--	20	--	Ω
Over-Voltage Protection of VOP	V _{OV1}	VON is from VOP	--	120	--	%
Enable						
Rising Input High Threshold Voltage Level	V _{IH}		1.2	--	V _{IN}	V
Falling Input High Threshold Voltage Level	V _{IL}		0	--	0.4	V
EN Pull Low Resistor Wake up Delay	R _{EN}		--	300	--	kΩ

Note 1. Stresses listed as the above "Absolute Maximum Ratings" June cause permanent damage to the device. These are for stress ratings. Functional operation of the device at these or any other conditions beyond those indicated in the operational sections of the specifications is not implied. Exposure to absolute maximum rating conditions for extended periods June remain possibility to affect device reliability.

Note 2. θ_{JA} is measured at T_A = 25°C on a high effective thermal conductivity four-layer test board per JEDEC 51-7. θ_{JC} is measured at the exposed pad of the package.

Note 3. Devices are ESD sensitive. Handling precaution recommended.

Note 4. The device is not guaranteed to function outside its operating conditions.

Note 5. I_{SS1}, I_{SS2}, T_{OTP}, T_{OTP_HYST} are guaranteed by design.

Typical Application Circuit

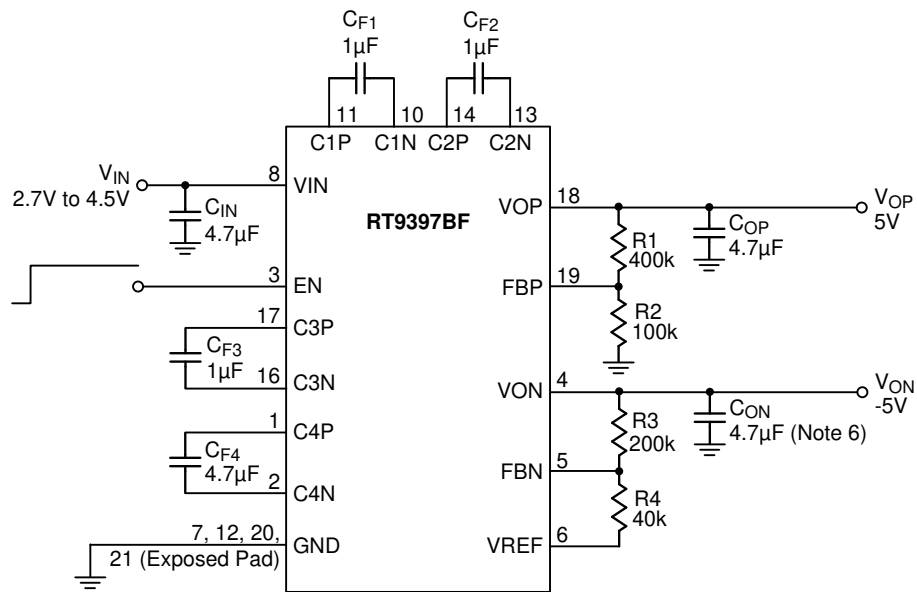

Note 6. Ripple voltage on V_{OP} and V_{ON} can be reduced with higher capacitance of C_{OP} and C_{ON} .

Time Diagram

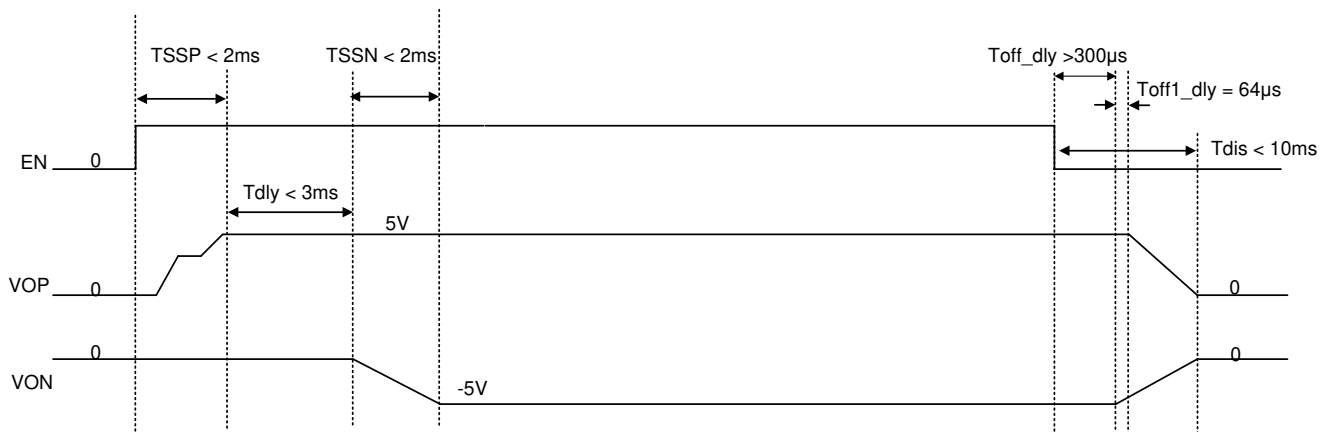

Typical Operating Characteristics

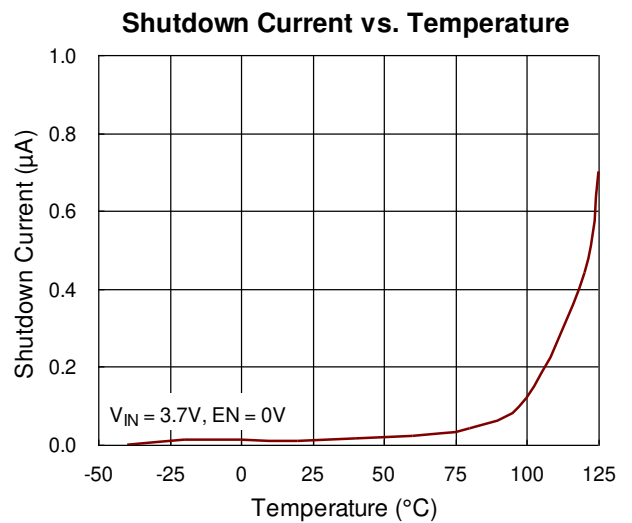
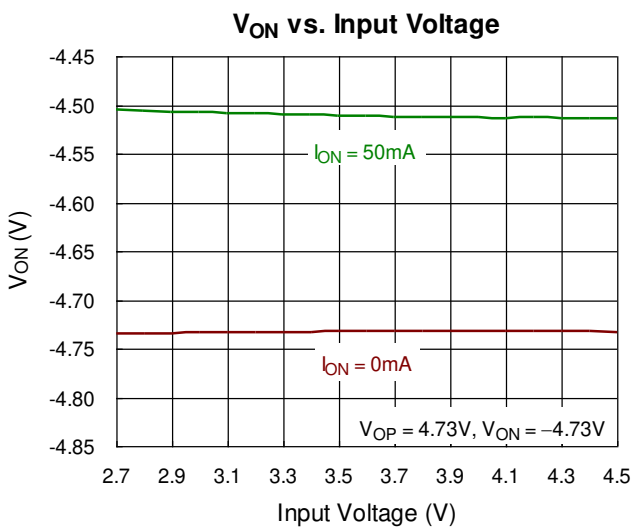
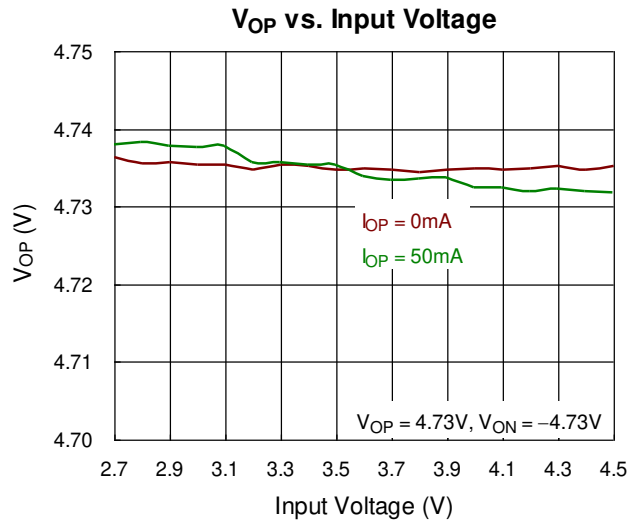
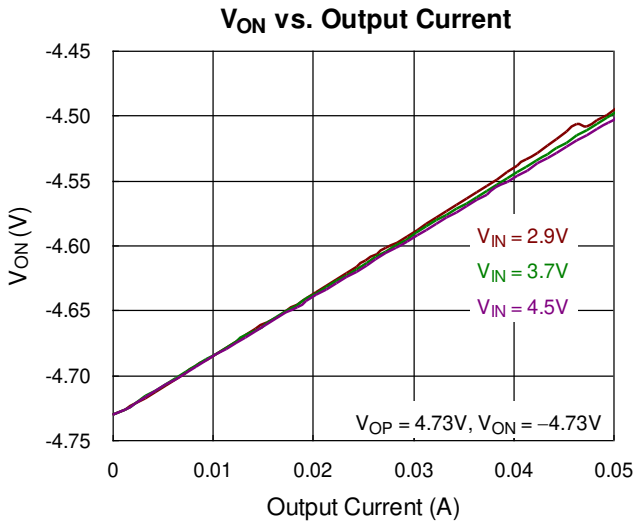
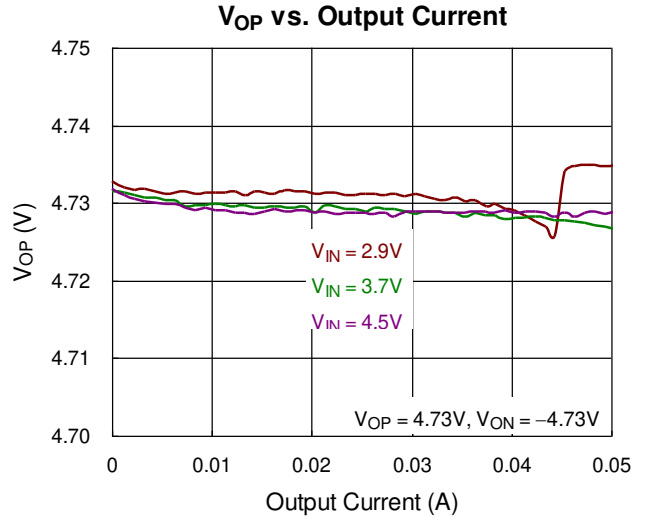
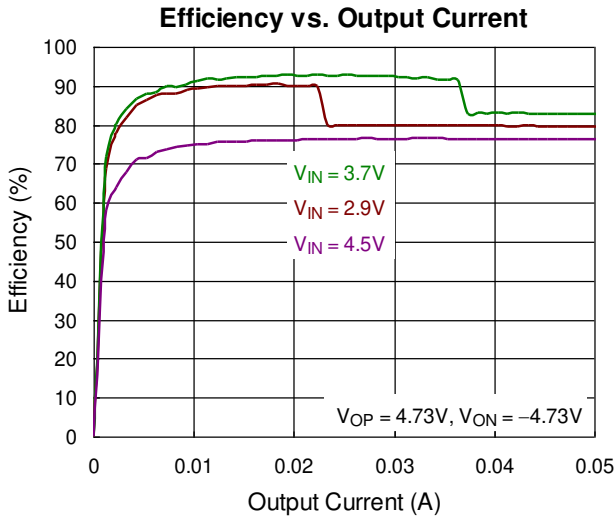

V_{OP} Load Transient

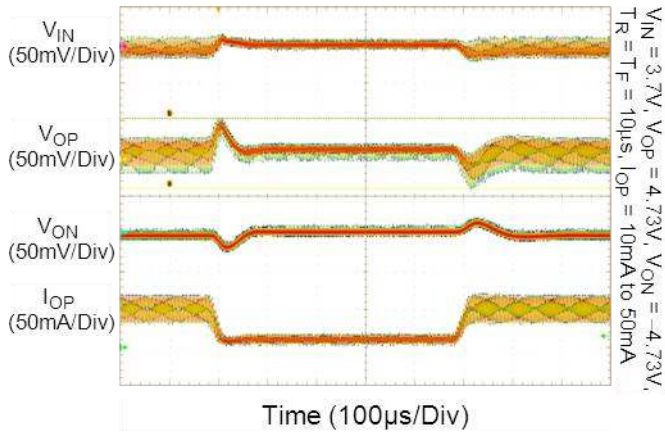

V_{OP} Line Transient

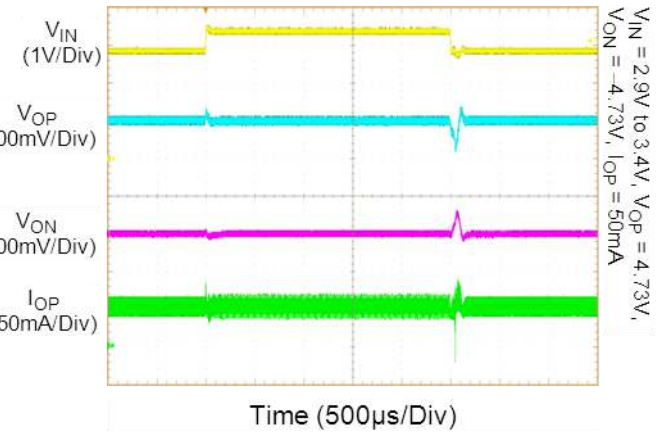

V_{OP} Line Transient

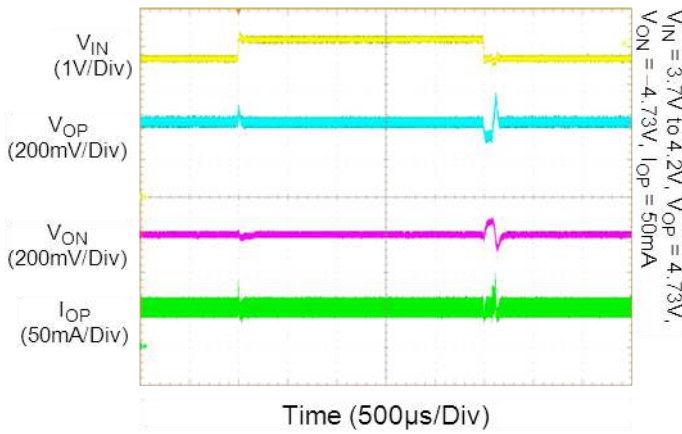

V_{ON} Load Transient

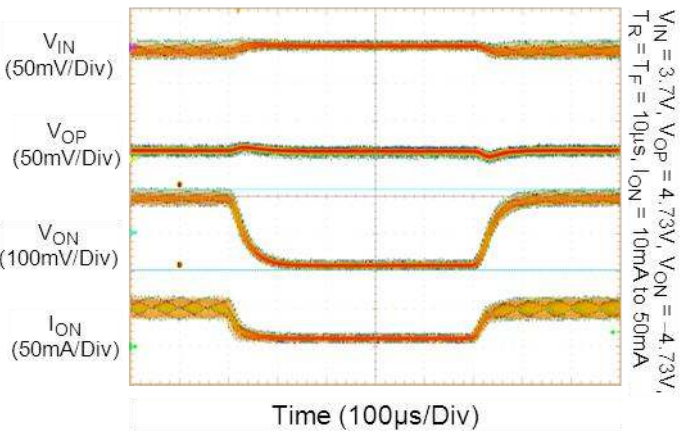

V_{ON} Line Transient

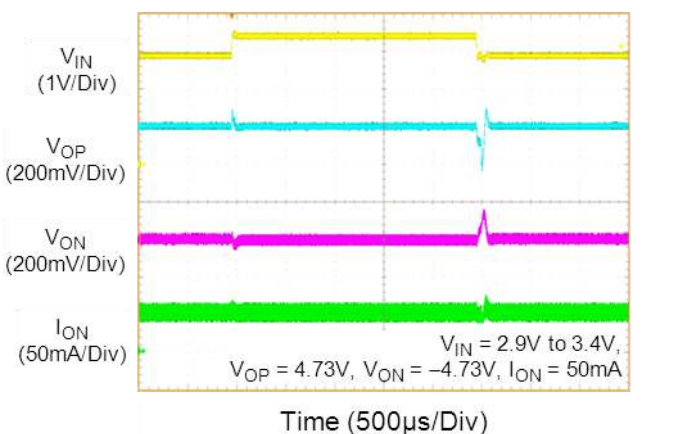

V_{ON} Line Transient

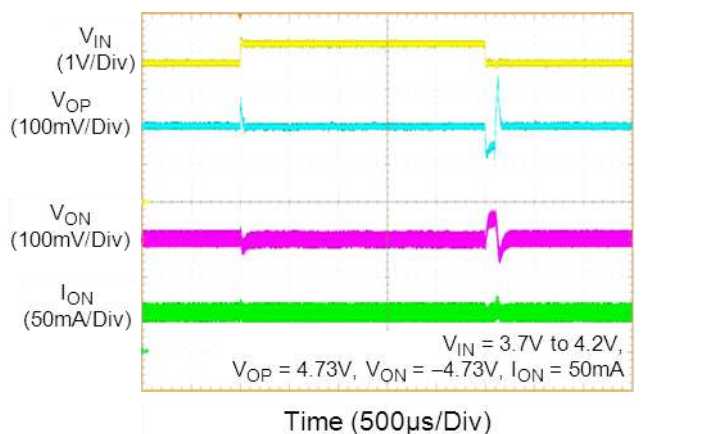

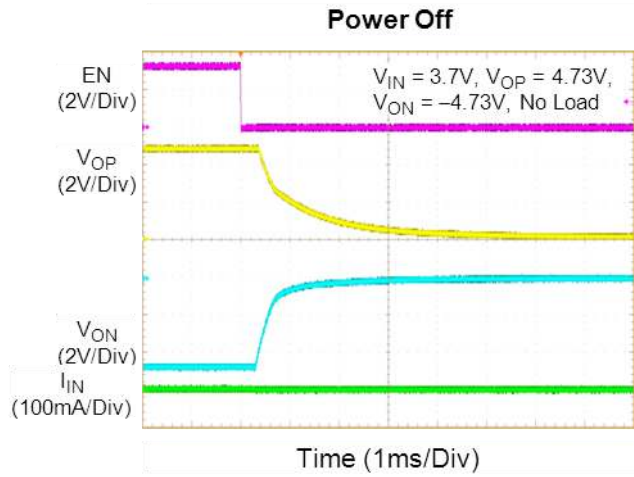
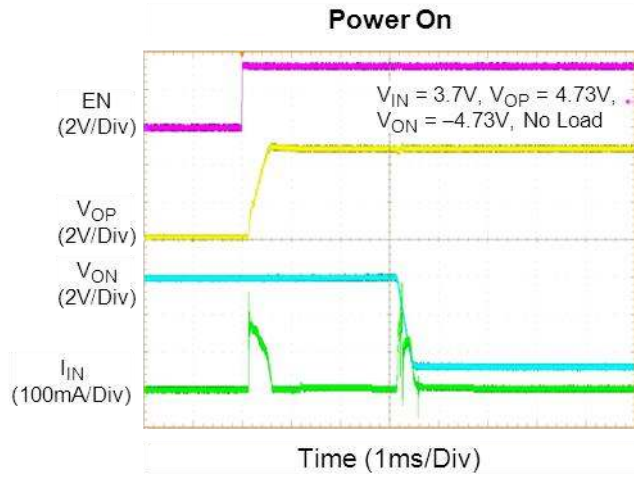

Applications Information

The RT9397BF is a highly integrated step-up charge pump and inverting charge pump to generate positive and negative output voltages for TFT-LCD bias. It can support input voltage range from 2.7V to 4.5V and the output current up to 50mA. Both positive and negative output voltages can be programmed by external feedback resistors.

Under Voltage Lockout

To prevent abnormal operation of the IC in low voltage condition, an under-voltage lockout is included which shuts down the device when input voltage is lower than 1.7V. All functions will be turned off in this state.

Soft-Start

The RT9397BF employs an internal soft-start feature to avoid high inrush current during start-up. An internal current source charges a capacitor to build the soft-start ramp voltage. The reference voltage will track the ramp voltage during soft-start interval. The typical soft-start time is 2ms.

Positive Output Voltage Setting

The output voltage setting can be calculated according to the following equation :

$$V_{OP} = V_{FBP} \times \left(1 + \frac{R1}{R2}\right)$$

where V_{FBP} is the reference voltage with a typical value of 1V.

Negative Output Voltage Setting

The output voltage setting can be calculated according to the following equation :

$$V_{ON} = V_{FBN} - (V_{REF} - V_{FBN}) \times \frac{R3}{R4}$$

where V_{REF} is the reference voltage with a typical value of 1V and $V_{FBN} = 0V$.

Over Temperature Protection (OTP)

The RT9397BF equips an over temperature protection circuitry to prevent overheating due to excessive power dissipation. The OTP will shut down IC operation when junction temperature exceeds 135°C. Once the junction

temperature cools down by approximately 10°C, IC will resume normal operation automatically. To maintain continuous operation, the maximum junction temperature should be prevented from rising above 125°C.

Over-Voltage Protection (OVP)

The RT9397BF has an over voltage protection to avoid incorrect feedback signal resulting in device damage. When the FBP pin voltage rises above 120% (typ.) of normal feedback voltage, the OVP will shut down IC operation. As soon as the output voltage falls below the over voltage threshold, the IC will resume operation after triggering the EN pin.

Short-Circuit Protection (SCP)

The RT9397BF has an advanced short-circuit protection mechanism which prevents the device from damage by unexpected applications. When the output becomes shorted to ground, the device enters shutdown mode and can only re-start normal operation after triggering the EN pin.

Shutdown Delay

When the EN voltage is logic low for more than 300μs, the IC will be shut down with an internal fast discharge resistor. In shutdown mode, the input supply current for the device is less than 1μA.

Headroom Voltage of V_{ON}

Due to the negative voltage V_{ON} is supplied from the positive voltage V_{OP} .

There is a voltage drop on the negative charge pump (-1X Mode) which equivalent resistance is about 50hm (typ.). The headroom voltage can be calculated depends on output load I_{ON} as below equation :

$$V_{ON} = -V_{OP} + I_{ON} \times R_{eq}$$

$$\text{Headroom} = V_{OP} + V_{ON} = I_{ON} \times R_{eq}$$

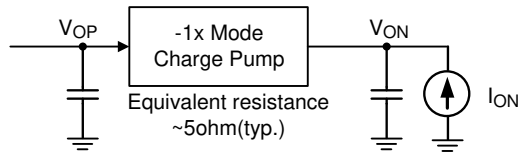

Thermal Considerations

For continuous operation, do not exceed absolute maximum junction temperature. The maximum power dissipation depends on the thermal resistance of the IC package, PCB layout, rate of surrounding airflow, and difference between junction and ambient temperature. The maximum power dissipation can be calculated by the following formula :

$$P_{D(MAX)} = (T_{J(MAX)} - T_A) / \theta_{JA}$$

where $T_{J(MAX)}$ is the maximum junction temperature, T_A is the ambient temperature, and θ_{JA} is the junction to ambient thermal resistance.

For recommended operating condition specifications, the maximum junction temperature is 125°C. The junction to ambient thermal resistance, θ_{JA} , is layout dependent. For WQFN-20L 3x3 package, the thermal resistance, θ_{JA} , is 30°C/W on a standard JEDEC 51-7 four-layer thermal test board. The maximum power dissipation at $T_A = 25^\circ\text{C}$ can be calculated by the following formula :

$$P_{D(MAX)} = (125^\circ\text{C} - 25^\circ\text{C}) / (30^\circ\text{C/W}) = 3.33\text{W for WQFN-20L 3x3 package}$$

The maximum power dissipation depends on the operating ambient temperature for fixed $T_{J(MAX)}$ and thermal resistance, θ_{JA} . The derating curve in Figure 1 allows the designer to see the effect of rising ambient temperature on the maximum power dissipation.

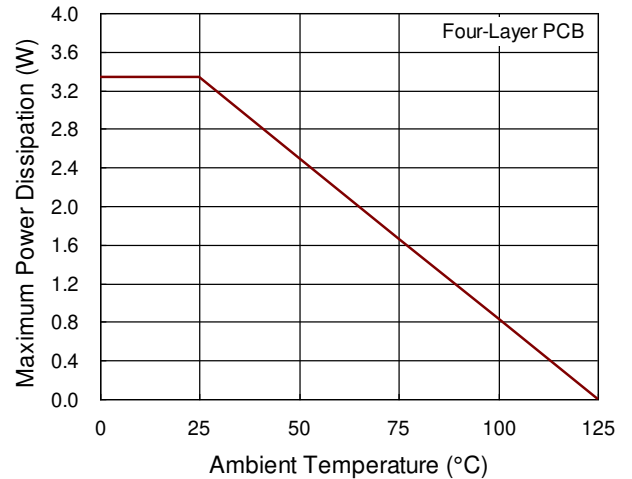

Figure 1. Derating Curve of Maximum Power Dissipation

Layout Consideration

For the best performance of RT9397BF the following PCB layout guidelines should be strictly followed.

- ▶ The traces should be wide and short especially for the high current output loop.
- ▶ The input and output bypass capacitor should be placed as close to the IC as possible and connected to the round plane of the PCB.
- ▶ Care should be taken to avoid running traces that carry any noise-sensitive signals near FBP, FBN pins.
- ▶ Connect the exposed pad to a strong ground plane for maximum thermal dissipation.

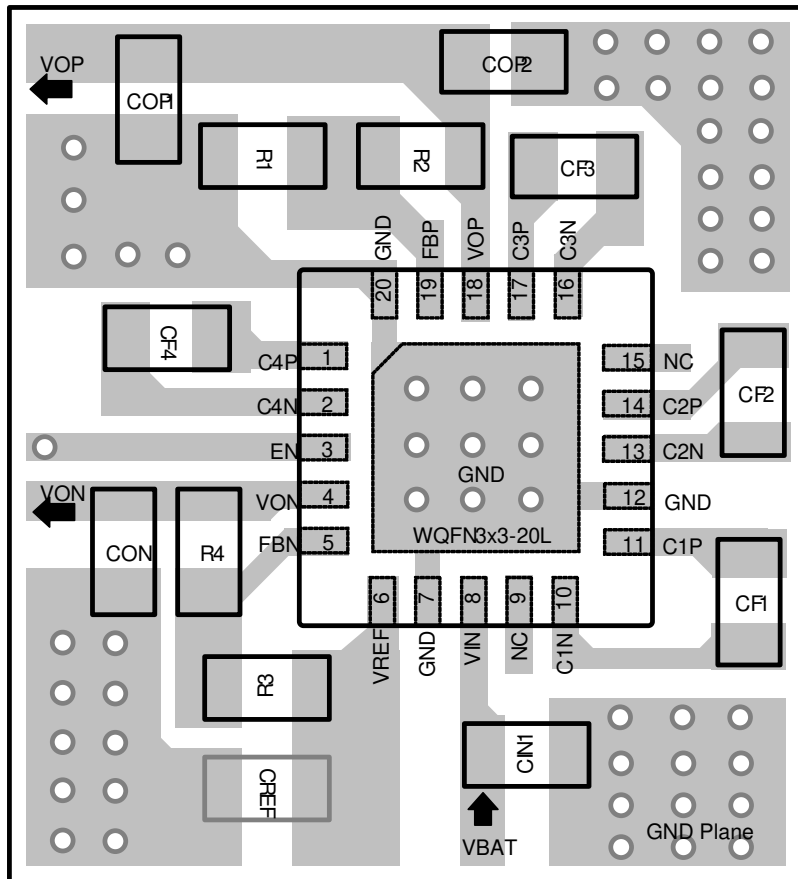
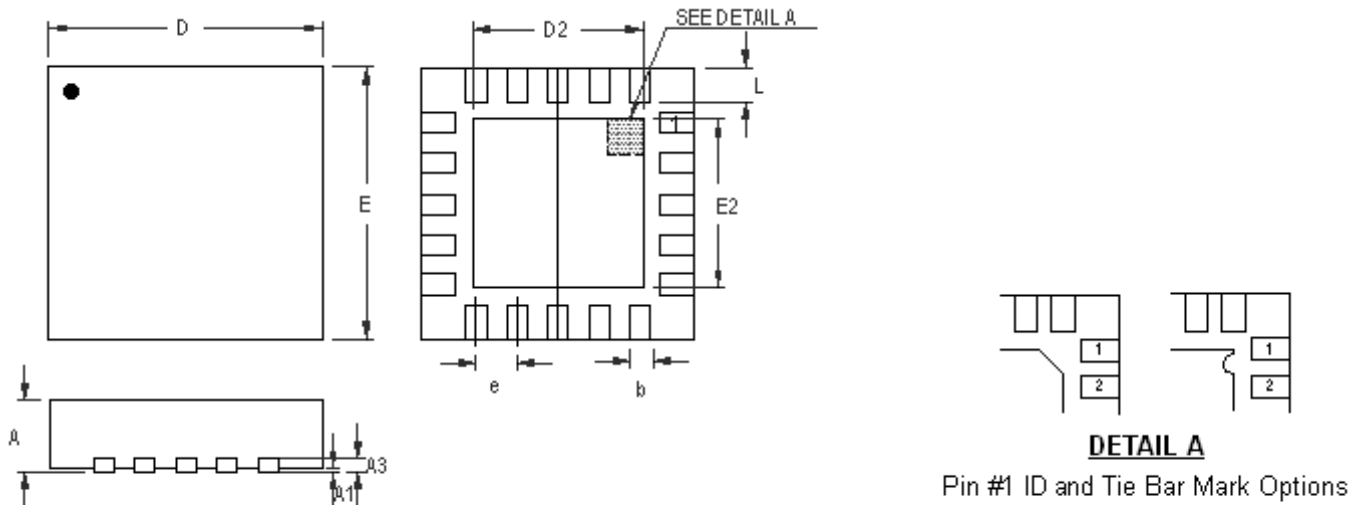

Figure 2. PCB Layout Guide

Outline Dimension



Note : The configuration of the Pin #1 identifier is optional, but must be located within the zone indicated.

Symbol	Dimensions In Millimeters		Dimensions In Inches	
	Min	Max	Min	Max
A	0.700	0.800	0.028	0.031
A1	0.000	0.050	0.000	0.002
A3	0.175	0.250	0.007	0.010
b	0.150	0.250	0.006	0.010
D	2.900	3.100	0.114	0.122
D2	1.650	1.750	0.065	0.069
E	2.900	3.100	0.114	0.122
E2	1.650	1.750	0.065	0.069
e	0.400		0.016	
L	0.350	0.450	0.014	0.018

W-Type 20L QFN 3x3 Package

Richtek Technology Corporation
 14F, No. 8, Tai Yuen 1st Street, Chupei City
 Hsinchu, Taiwan, R.O.C.
 Tel: (8863)5526789

Richtek products are sold by description only. Richtek reserves the right to change the circuitry and/or specifications without notice at any time. Customers should obtain the latest relevant information and data sheets before placing orders and should verify that such information is current and complete. Richtek cannot assume responsibility for use of any circuitry other than circuitry entirely embodied in a Richtek product. Information furnished by Richtek is believed to be accurate and reliable. However, no responsibility is assumed by Richtek or its subsidiaries for its use; nor for any infringements of patents or other rights of third parties which result from its use. No license is granted by implication or otherwise under any patent or patent rights of Richtek or its subsidiaries.

Copyright © 2014 Richtek Technology Corporation. All rights reserved. **RICHTEK** is a registered trademark of Richtek Technology Corporation.