





# SPECIFICATIONS

**CUSTOMER** : \_\_\_\_\_  
**MODEL NO.** :           GFT035EA320240            
**VERSION** :                           H                            
**DATE** :                           2022.11.15                            
**CERTIFICATION** :                           ROHS                          

Customer Sign	Sales Sign	Approved By	Prepared By
			

晶發科技股份有限公司  
GI FAR TECHNOLOGY CO.,LTD

新北市樹林區東豐街 81 號

No. 81, Dongfeng St, Shulin District, 238034, New Taipei City, Taiwan, R.O.C.  
 TEL: +886-2-8684-1188 FAX: +886-2-8684-8532





## Contents

### 1. SPECIFICATIONS

- 1.1 Features
- 1.2 Mechanical Specifications
- 1.3 Absolute Maximum Ratings
- 1.4 DC Electrical Characteristics
- 1.5 Optical Characteristics
- 1.6 Backlight Characteristics

### 2. MODULE STRUCTURE

- 2.1 Counter Drawing
- 2.2 Interface Pin Description
- 2.3 Timing Characteristics
  - 2.3.1 SPI Read
  - 2.3.2 SPI Write
  - 2.3.3 SPI Timing Table
- 2.4 Power Sequence
  - 2.4.1 Power up sequence
  - 2.4.2 Power down sequence
- 2.5 Reference Initial code

### 3. QUALITY ASSURANCE SYSTEM

- 3.1 Quality Assurance Flow Chart
- 3.2 Inspection Specification

### 4. RELIABILITY TEST

- 4.1 Reliability Test Condition

### 5. PRECAUTION RELATING PRODUCT HANDLING

- 5.1 Safety
- 5.2 Handling
- 5.3 Storage
- 5.4 Terms of Warranty

Appendix : LCM Drawing  
Packaging

Note : For detailed information please refer to IC data sheet: Primacy(TFT LCD) : Himax HX8238-D



# 1. SPECIFICATIONS

## 1.1 Features

Main LCD panel

Item	Standard Value
Display Type	320(R · G · B)*240 Dots
LCD Type	Normally white, Transmissive type
Screen size (inch)	3.5 inch
Viewing Direction	6 O'clock
Color configuration	RG.B-Strip
Backlight	LED
Interface	Digital 24-bits RGB
Other(controller/driver IC)	Himax:HX8238-D
ROHS	This product conforms the ROHS of ptc

## 1.2 Mechanical Specifications

Item	Standard Value	Unit
Outline Dimension	76.9 (W) * 63.9(L)*2.85(H)	mm

### LCD panel

Item	Standard Value	Unit
Viewing Area	72.9(W) * 55.5(L)	mm
Active Area	70.08 (W) * 52.56(L)	mm

Note: For detailed information please refer to LCM drawing



### 1.3 Absolute Maximum Ratings

#### Module

Item	Symbol	Condition	Min.	Max.	Unit
System Power Supply Voltage	VDDIO	VSS=0	-0.3	4.0	V
Operating Temperature	T <sub>OP</sub>	-	-20	70	°C
Storage Temperature	T <sub>ST</sub>	-	-30	80	°C

### 1.4 DC Electrical Characteristics

#### Module

VSS = 0V, Ta=25°C

Item	Symbol	Condition	Min.	Typ.	Max.	Unit
Power Supply Voltage1	VDDIO	-	3.0	3.3	3.6	V
V <sub>COM</sub> High Voltage	V <sub>COMH</sub>	-	2.5	(3.6)	4.5	V
V <sub>COM</sub> Low Voltage	V <sub>COML</sub>	-	-3	(-2.4)	0	V
Supply Current	IDD	VDD= 3.3 V Pattern = black *1	-	5.5	8.5	mA

Note 1 : Maximum current display



## 1.5 Optical Characteristics

TFT LCD panel

VDDIO=3.3V, Ta=25°C

Note A:

Item	Symbol	Condition	Min.	Typ.	Max.	Unit	-	
Response time	Tr+Tf	Ta=25°C ΘX,Θy=0°	-	50	53	ms	Note2	
Viewing angle	Top	ΘY+	CR ≥ 10	-	45	-	Deg.	Note4
	Bottom	ΘY-		-	50	-		
	Left	ΘX-		-	50	-		
	Right	ΘX+		-	50	-		
Contrast ratio	CR	Ta = 25°C ΘX,ΘY=0°	200	250	-	-	Note3	
Color of CIE Coordinate(With B/L)	White	X	-	0.259	0.309	0.359	-	Note1
		Y		0.274	0.324	0.374		
	Red	X		0.573	0.623	0.673		
		Y		0.310	0.360	0.410		
	Green	X		0.291	0.341	0.391		
		Y		0.547	0.597	0.647		
	Blue	X		0.094	0.144	0.194		
		Y		0.029	0.079	0.129		
Average Brightness Pattern=white display (with B/L)*1	IV	IF=20 mA	250	270	-	Cd/m <sup>2</sup>		
Uniformity (With B/L)*2	ΔB	IF=20 mA	70	-	-	%		

\*1.  $\Delta B = B(\min) / B(\max) * 100\%$

\*2: Measurement Condition for Optical Characteristics:

a: Environment: 25°C ± 5°C / 60 ± 20% R.H , no wind , dark room below 10 Lux at typical lamp current and typical operating frequency.

b: Measurement Distance: 500 ± 50mm , (θ = 0° )

c: Equipment: TOPCON BM-7 fast , (field 1° ), after 10 minutes operation.

d: The uncertainty of the C.I.E coordinate measurement ± 0.01 , Average Brightness ± 4%

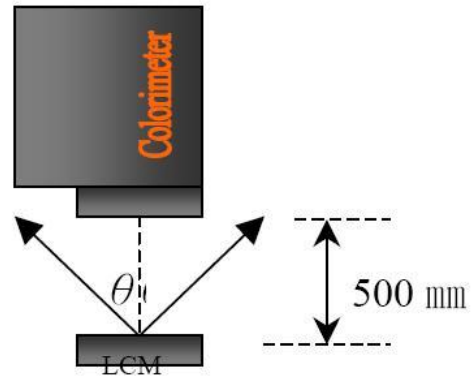
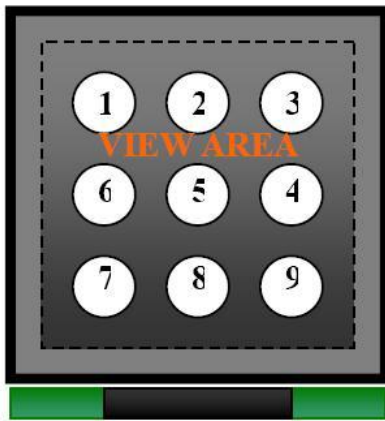

Colorimeter=BM-7 fast

To be measured at the center area of panel with a viewing cone of  $1^\circ$  by Topcon luminance meter BM-7, after 10 minutes operation (module)

Note2: Definition of response time:

The output signals of photo detector are measured when the input signals are changed from "black" to "white" (falling time) and from "white" to "black" (rising time), respectively. The response time is defined as the time interval between the 10% and 90% of Amplitudes.

Refer to figure as below:

Normally White

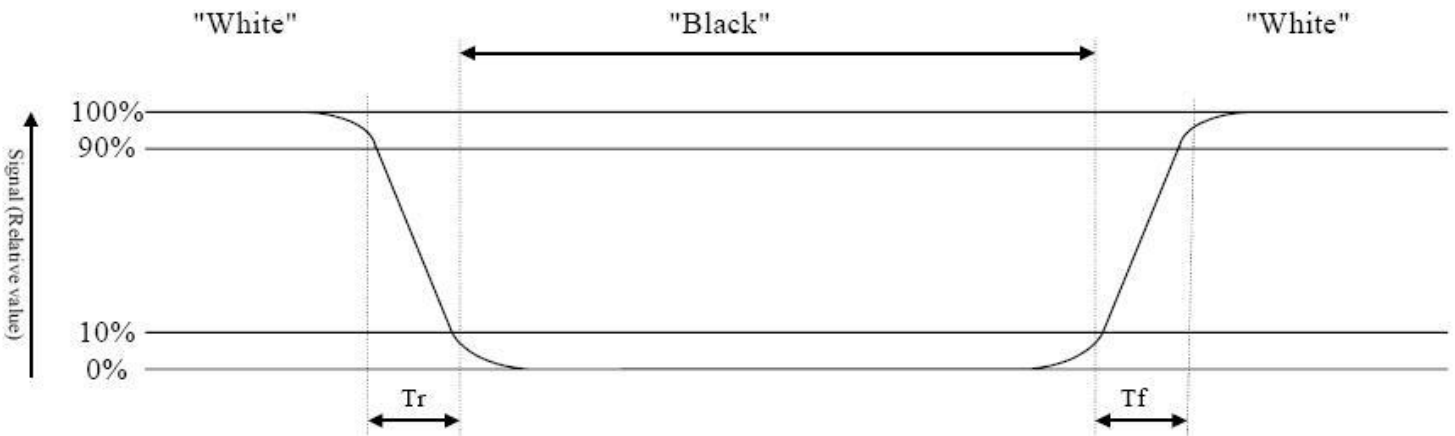

Normally Black

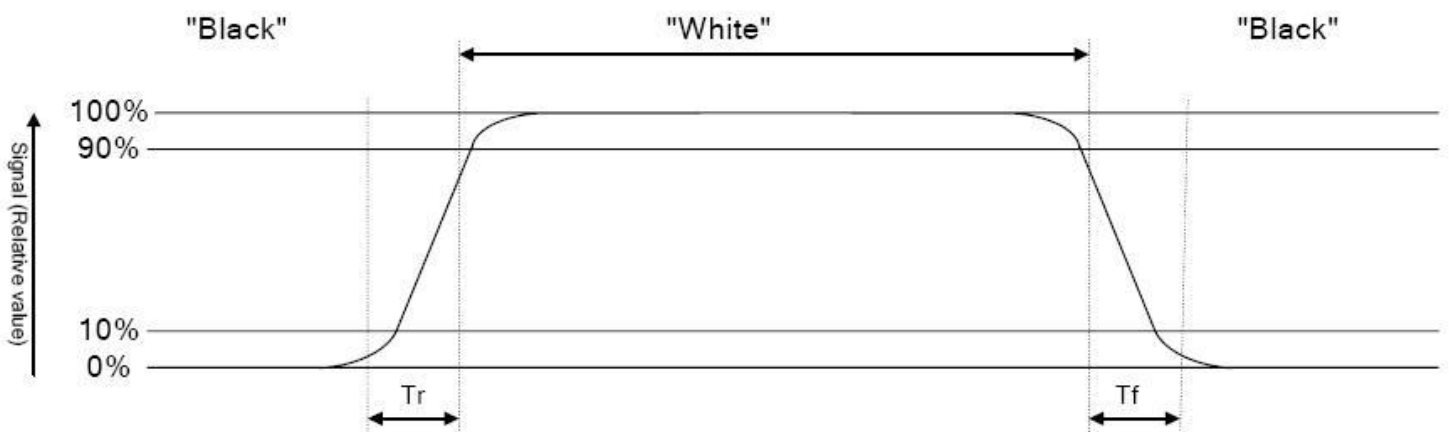





Note 3: Definition of contrast ratio:

Contrast ratio is calculated with the following formula

$$\text{Contrast ration (CR)} = \frac{\text{Photo detector output when LCD is at "White" state}}{\text{Photo detector output when LCD is at "Black" state}}$$

Note 4: Definition of viewing angle:

Refer to figure as below:

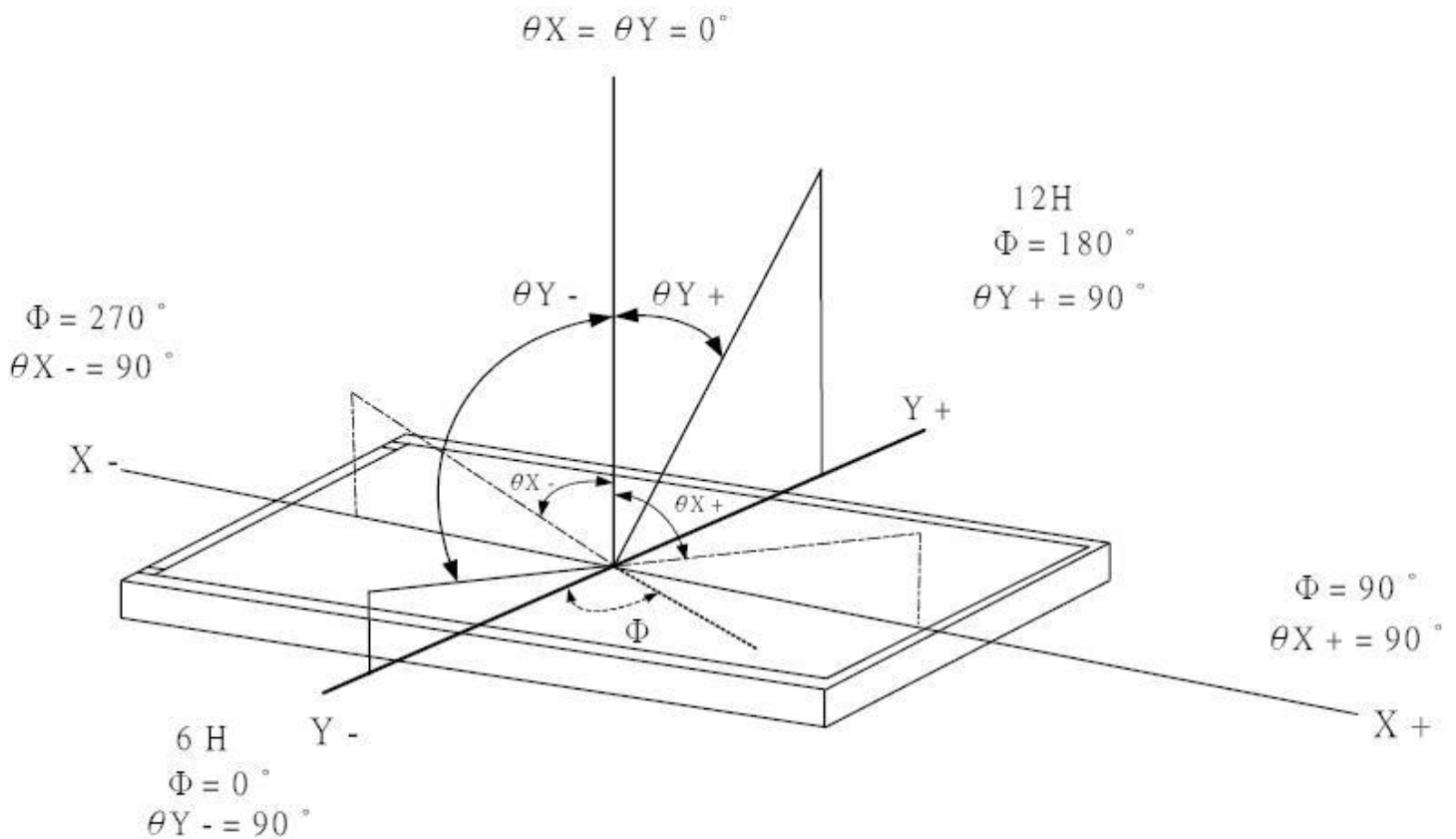





## 1.6 Backlight Characteristics

### Maximum Ratings

Item	Symbol	Conditions	Min.	Max.	Unit
Forward Current	IF	Ta=25°C	-	30	mA
Reverse Voltage	VR	Ta=25°C	-	5	V
Power Dissipation	PD	Ta=25°C	-	0.648	W

### Electrical / Optical Characteristics

Item	Symbol	Conditions	Min.	Typ.	Max.	Unit
Forward Voltage	VF		16.8	19.8	21.6	V
Average Brightness(Without LCD)	IV	IF=20mA	4500	-	-	Cd/m <sup>2</sup>
CIE Color Coordinate(without LCD)	X		0.28	0.305	0.33	-
	Y	0.275	0.30	0.325		
Color		White				

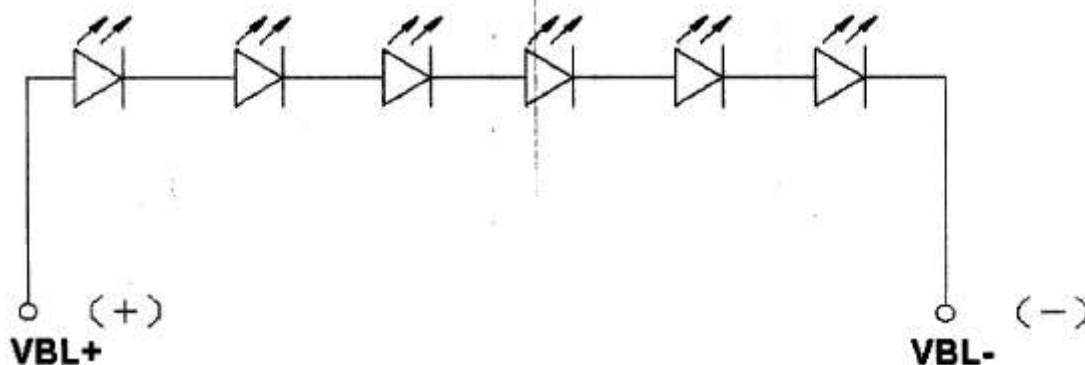



## 2. MODULE STRUCTURE

### 2.1 Counter Drawing

#### 2.1.1 LCM Mechanical Diagram

\* See Appendix

#### 2.1.2 Block Diagram

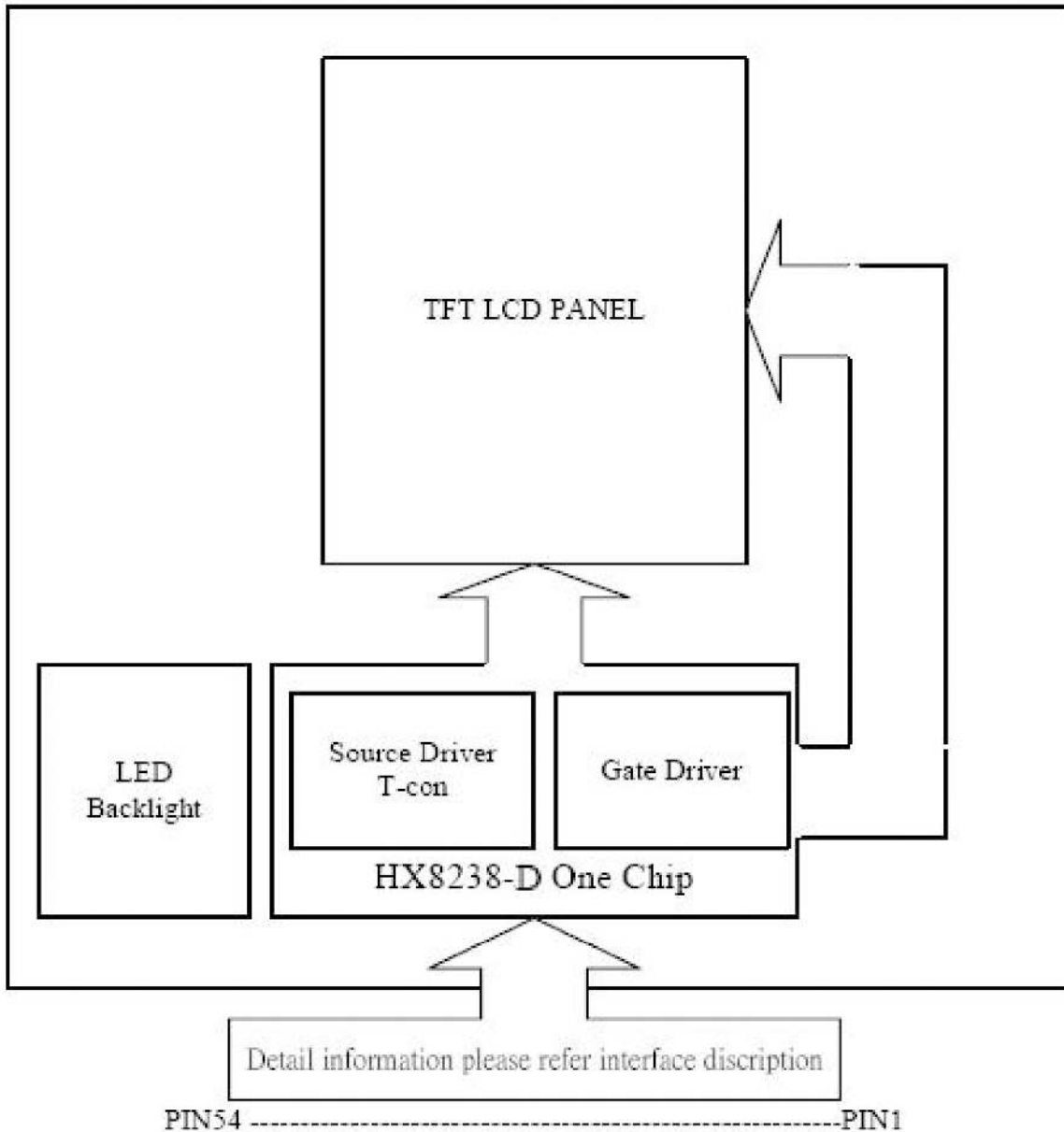



## 2.2 Interface Pin Description

Pin No.	Symbol	Function
1	VBL-	Power supply for LED Backlight cathode input
2	VBL-	Power supply for LED Backlight cathode input
3	VBL+	Power supply for LED Backlight anode input
4	VBL+	Power supply for LED Backlight anode input
5	NC	Not used, Must be open
6	NC	Not used, Must be open
7	NC	Not used, Must be open.(Output Pin, POL output.)
8	/RESET	Hardware reset
9	SPENA	Serial port data enable signal
10	SPCLK	Serial data clock
11	SPDAT	Serial data
12	B0	Blue data bit 0
13	B1	Blue data bit 1
14	B2	Blue data bit 2
15	B3	Blue data bit 3
16	B4	Blue data bit 4
17	B5	Blue data bit 5
18	B6	Blue data bit 6
19	B7	Blue data bit 7
20	G0	Green data bit 0
21	G1	Green data bit 1
22	G2	Green data bit 2
23	G3	Green data bit 3
24	G4	Green data bit 4
25	G5	Green data bit 5
26	G6	Green data bit 6
27	G7	Green data bit 7
28	R0	Red data bit 0
29	R1	Red data bit 1
30	R2	Red data bit 2
31	R3	Red data bit 3
32	R4	Red data bit 4
33	R5	Red data bit 5
34	R6	Red data bit 6
35	R7	Red data bit 7
36	HSYNC	Horizontal sync input
37	VSYNC	Vertical sync input



38	DOTCLK	Dot data clock
39	VDDIO	Digital power
40	VDDIO	Digital power
41	VDDIO	Digital power
42	VDDIO	Digital power
43	NC	Not used, Must be open
44	NC	Not used, Must be open
45	NC	Not used, Must be open (Output Pin, V <sub>GL</sub> , Gate off power.)
46	NC	Not used, Must be open
47	NC	Not used, Must be open (Output Pin, V <sub>GH</sub> , Gate on power.)
48	NC	Not used, Must be open
49	NC	Not used, Must be open
50	NC	Not used, Must be open
51	NC	Not used, Must be open (Output Pin, VCOM power.)
52	ENB	Data enable control
53	VSS	Ground
54	VSS	Ground



## 2.3 Timing Characteristics

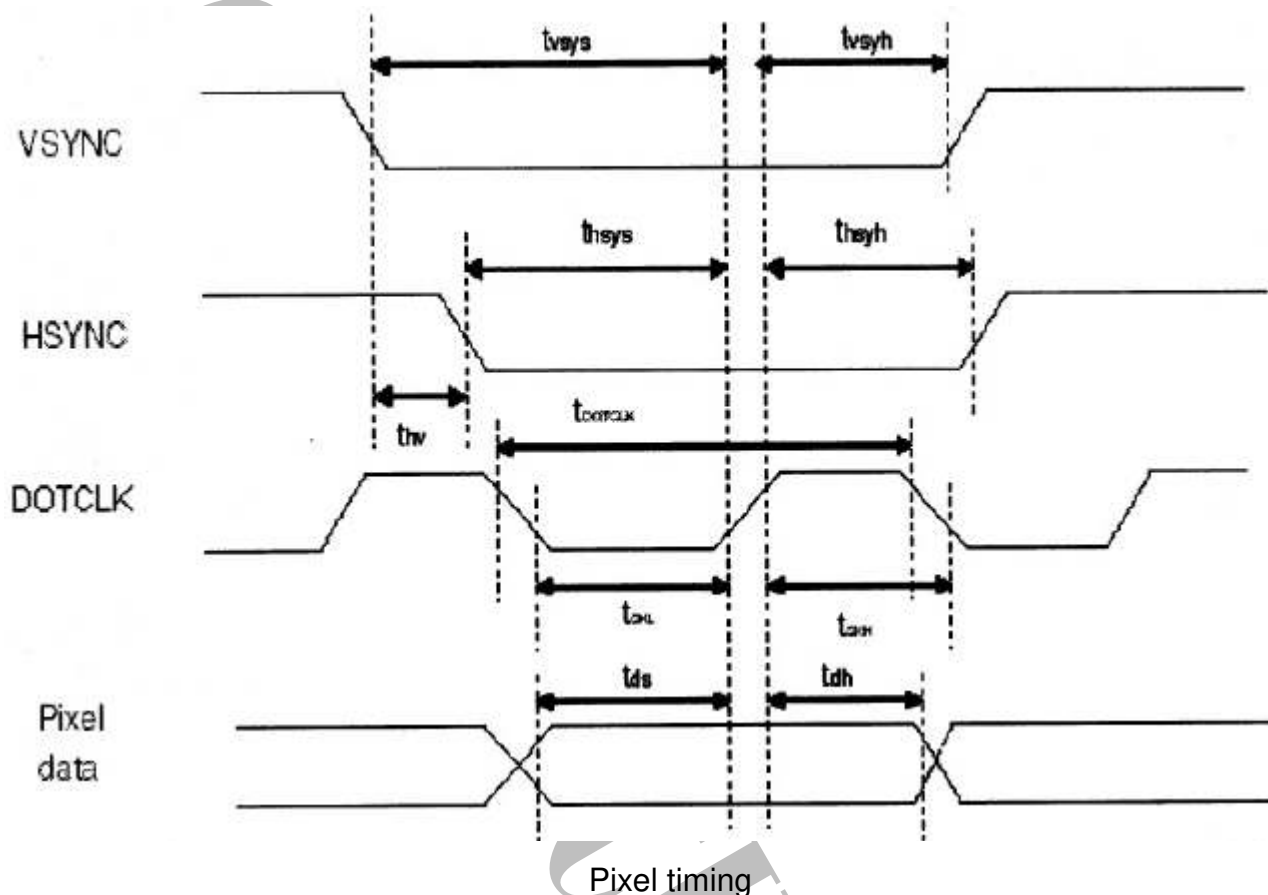

Pixel timing

Characteristics	Symbol	Min		Typ		Max		Unit
		24 bit	8 bit	24 bit	8 bit	24 bit	8 bit	
DOTCLK Frequency	fDOTCLK	-	-	6.5	19.5	10	30	MHz
DOTCLK Period	tDOTCLK	100	33.3	154	51.3	-	-	ns
Vertical Sync Setup Time	tvsys	20	10	-	-	-	-	ns
Vertical Sync Hold Time	tvsyh	20	10	-	-	-	-	ns
Horizontal Sync Setup Time	thsys	20	10	-	-	-	-	ns
Horizontal Sync Hold Time	thsyh	20	10	-	-	-	-	ns
Please difference of Sync Signal Falling Edge	tthv	1		-	-	240		tDOTCLK
DOTCLK Low Period	tCKL	50	15	-	-	-	-	ns
DOTCLK High Period	tCKH	50	15	-	-	-	-	ns
Data Setup Time	tds	12	10	-	-	-	-	ns
Data hold Time	tdh	12	10	-	-	-	-	ns
Reset pulse width	tRES	10		-	-	-	-	us

Pixel timing

Note : The interface of this module can drive by digital 24-bit data.



### 2.3.1 SPI Read

First Transmission (Register)

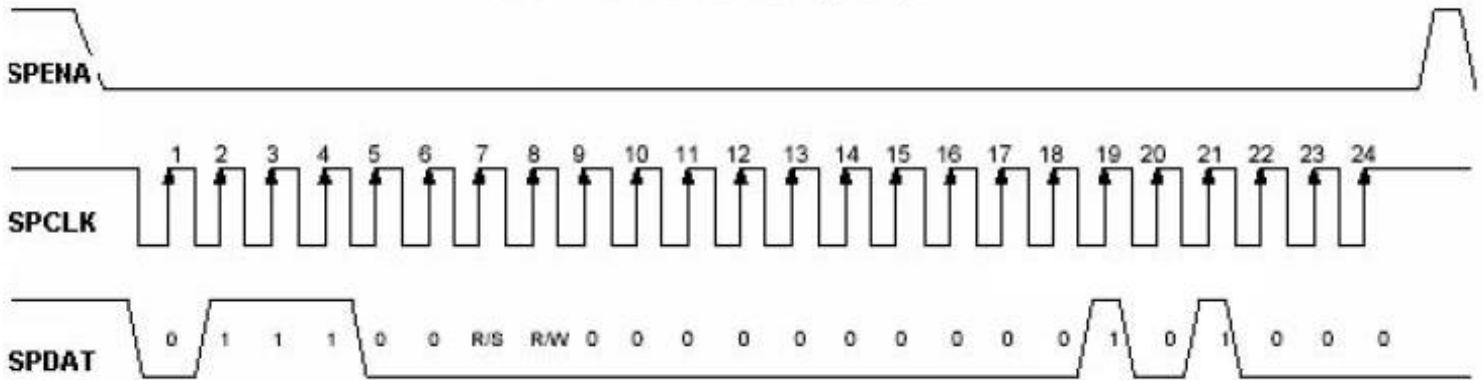

Second Transmission (Data)

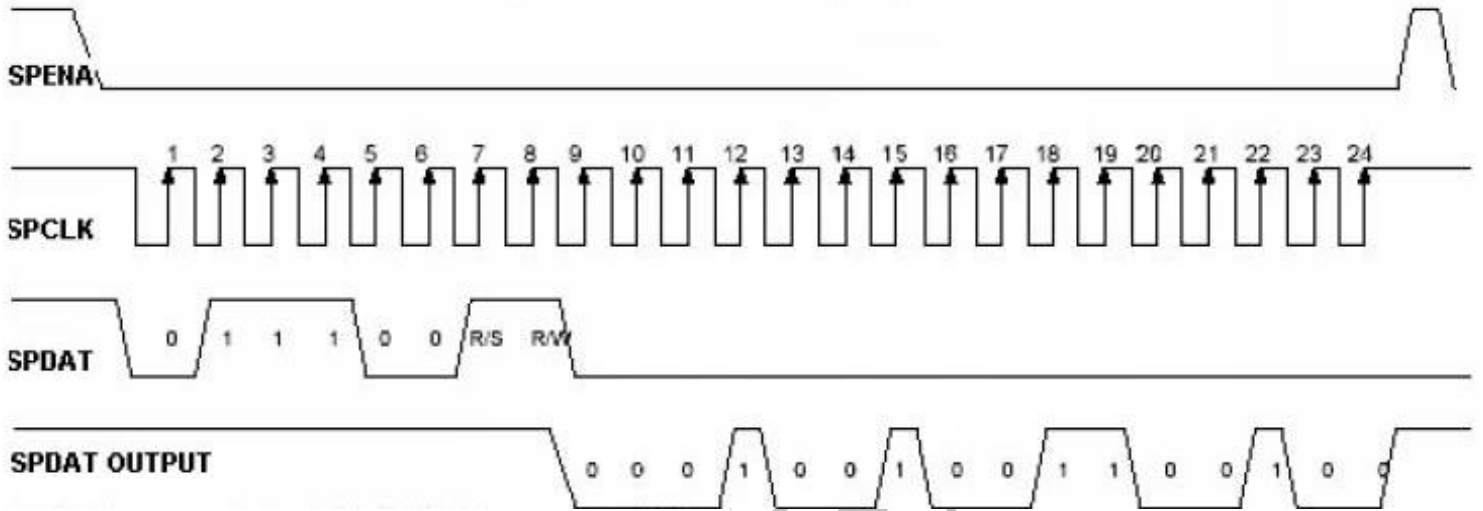

Note : The example writes "0x1264h" to register R28h.

SPI interface Timing Diagram & Read SPI Example





### 2.3.2 SPI Write

First Transmission (Register)

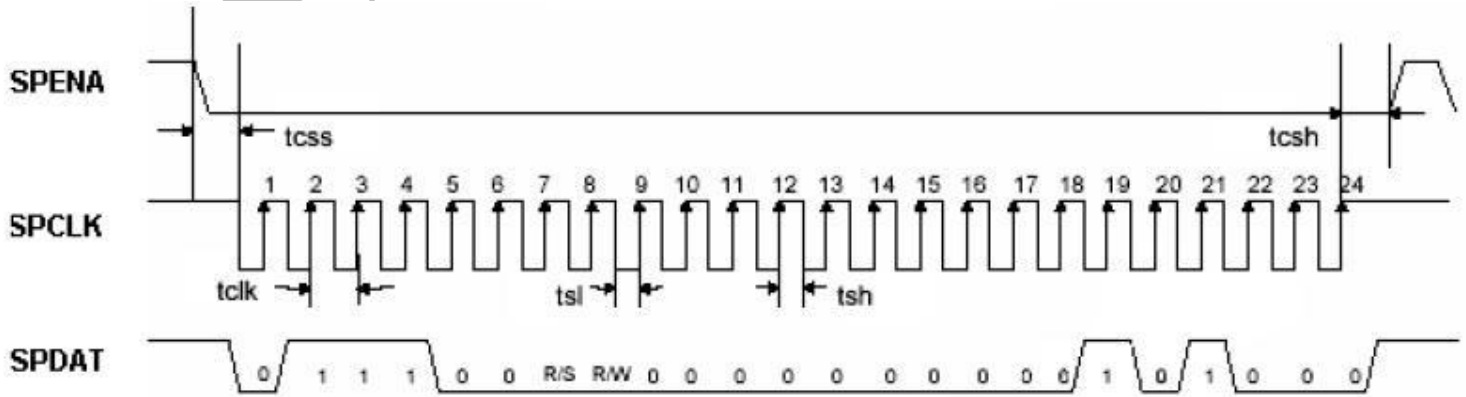

Second Transmission (Data)

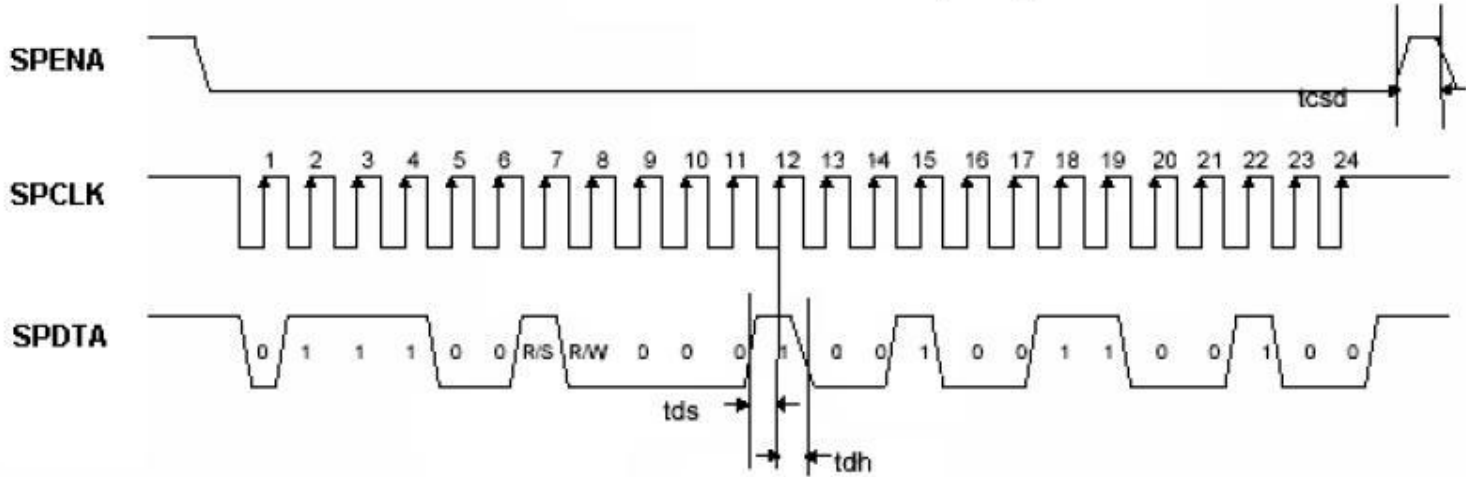

Note: The example writes "0x1264h" to register R28h.

SPID connected to VSS.

### SPI interface Timing Diagram & Write SPI Example

#### 2.3.3 SPI Timing Table

Characteristics	Symbol	Min	Typ	Max	Unit
Serial Clock Frequency	fclk	-	-	20	MHz
Serial Clock Cycle Time	tclk	50	-	-	ns
Clock Low Width	tsl	25	-	-	ns
Clock High Width	tsh	25	-	-	ns
Clock Rising Time	trs	-	-	30	ns
Clock Falling Time	tfl	-	-	30	ns
Chip Select Setup Time	tcss	0	-	-	ns
Chip Select Hold Time	tcsh	10	-	-	ns
Chip Select High Delay Time	tcsd	20	-	-	ns
Data Select Time	tds	5	-	-	ns
Data Hold Time	tdh	10	-	-	ns

#### SPI Timing





## 2.4 Power Sequence

### 2.4.1 Power up sequence

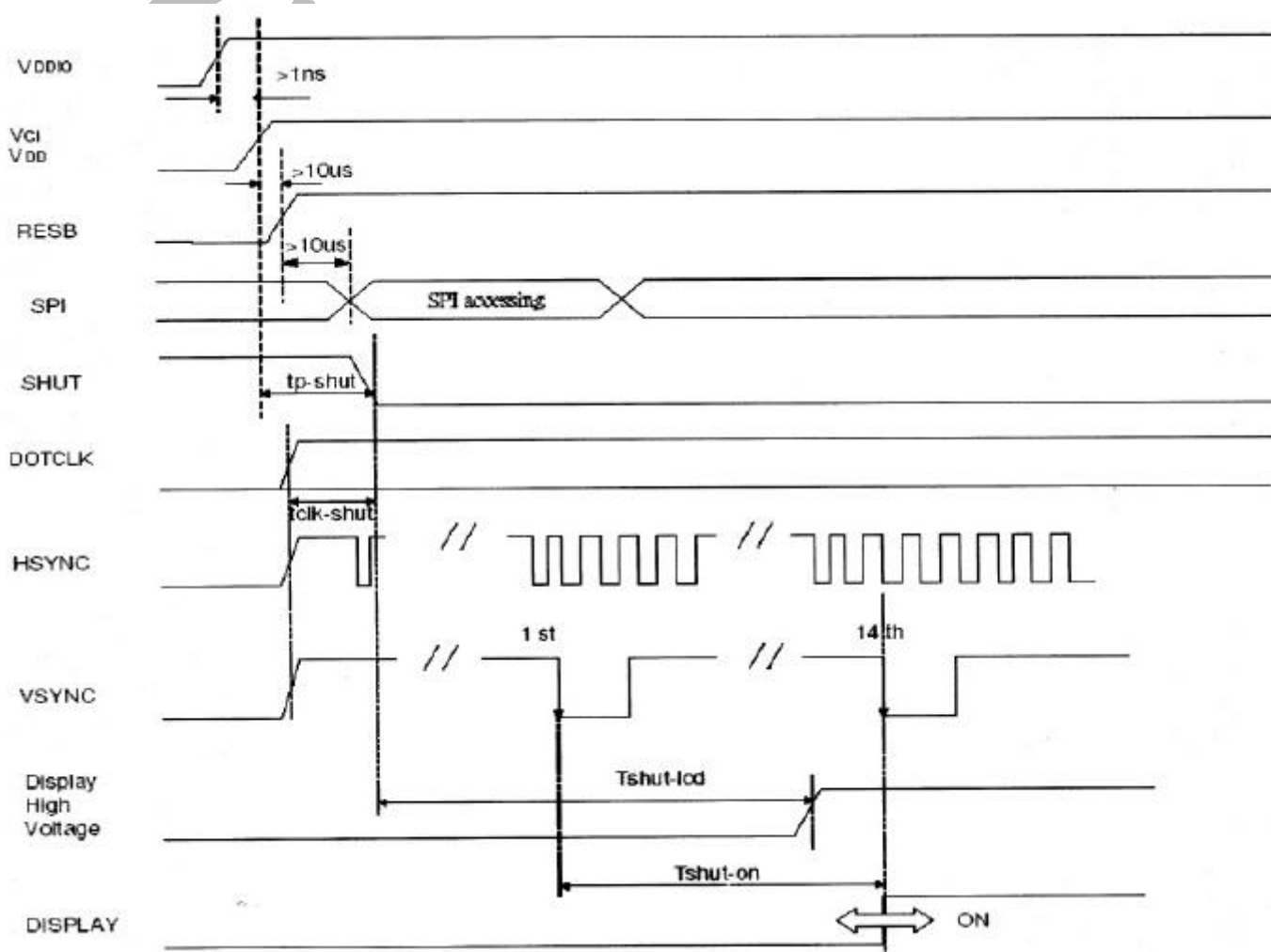

Characteristics	Symbol	Min	Typ	Max	Unit
VDDD/VDDIO on to falling edge of SHUT	$tp\_shut$	1	-	-	us
DOTCLK	$tclk\_shut$	1	-	-	clk
Falling edge of SHUT to LCD power on	$tshut-lcd$	-	-	128	ms
Falling edge of SHUT to display start	$tshut-on$	-	-	14	frame
- 1 line : 408 clk - 1 frame : 262 line - DOTCLK = 6.5 MHz		-	166	232.4	ms

Note: It is necessary to input DOTCLK before the falling edge of SHUT.

Display starts at 10<sup>th</sup> falling edge of VSTNC after the falling edge of SHUT.

Note: 1、The voltage of VDD be boosted from VDDIO.



## 2.4.2 Power down sequence

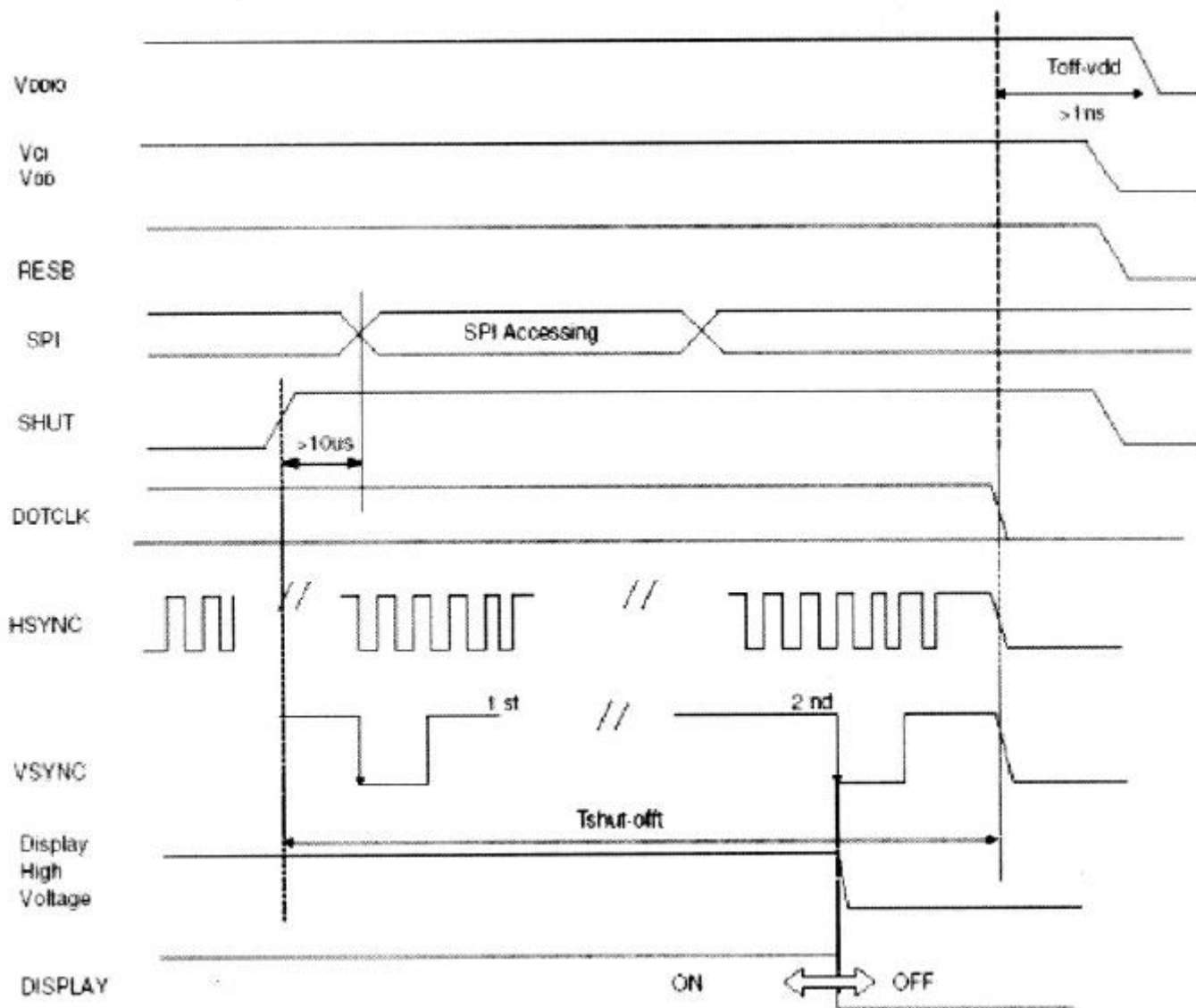

Characteristics	Symbol	Min	Typ	Max	Unit
Rising edge of SHUT to display off -1 line : 408 clk -1 frame: 262 line -DOTCLK = 6.5MHz	tshut-off	2	-	-	frame
		33.4	-	-	ms
Input-signal-off to VDDD/VDDIO off	toff-vdd	1	-	-	us

Note: DOTCLK must be maintained at least 2 frames after the rising edge of SHUT.  
Display become off at the 2nd falling edge of VSTNC after the falling edge of SHUT.  
If RESET signal is necessary for power down, provide it after the 2-frames-cycle of the SHUT period.

Note : 1 、 The voltage of VDD be boosted from VDDIO.



## 2.5 Reference Initial code

Register (0x0001);  
Data (0x7300);

Register (0x0002);  
Data (0x0200);

Register (0x0003);  
Data (0x6164);

Register (0x0004);  
Data (0x04C7);

Register (0x0005);  
Data (0xFC80);

Register (0x00,0x0A); //Contrast/ Brightness control;  
Data (0x4008);

Register (0x00,0x0D); //Power control (2);  
Data (0x3229);

Register (0x00,0x0E); //Power control (3); VOML  
Data (0x3200);

\*\*\*\*\*

Flicker!!! Piz , download below.

Register (0x00,0x1E); //Power control (4); COMH  
Data(0x00DF);

\*\*\*\*\*



### 3. QUALITY ASSURANCE SYSTEM

#### 3.1 Quality Assurance Flow Chart

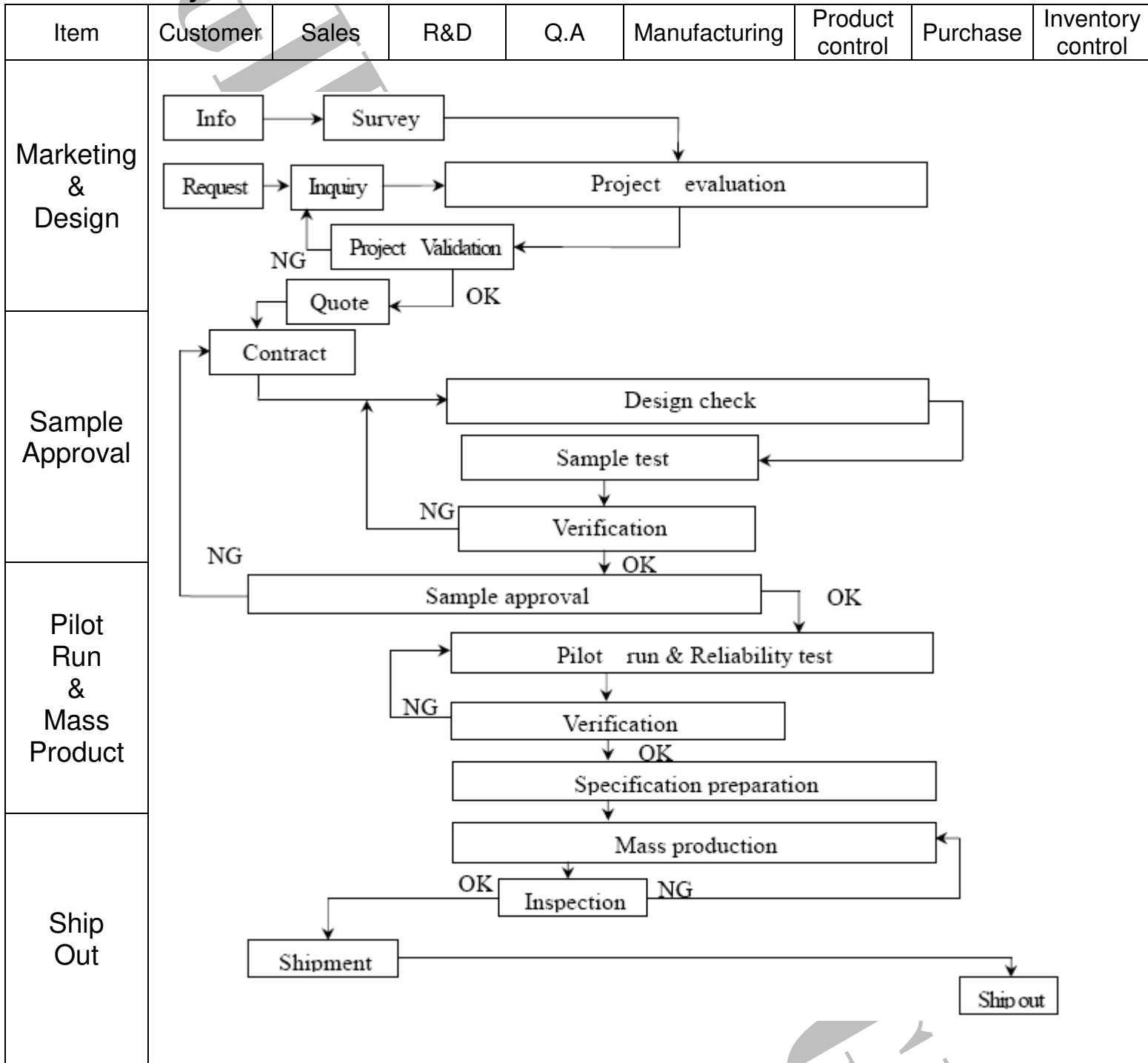



Item	Customer	Sales	R&D	Q.A	Manufacturing	Product control	Purchase	Inventory control
Sales Service	<pre> graph TD     Info[Info] --&gt; Claim[Claim]     Claim --&gt; FA[Failure analysis]     Claim --&gt; AR[Analysis report]     FA --&gt; CA[Corrective action]     CA --&gt; Tracking[Tracking]           </pre>							
Q.A Activity	1.ISO 9001 Maintenance Activities 3.Equipment calibration 5.Standardization Management				2.Process improvement proposal 4.Education And Training Activities			

FOR INTERNAL USE ONLY



### 3.2 Inspection Specification

#### 1. Inspection Specification

- ◆ Scope : The document shall be applied to TFT-LCD Module for less than 3.5"~10" (Ver:02).
- ◆ Inspection Standard : MIL-STD-105E Table Normal Inspection Single Sampling Level II .
- ◆ Equipment : Gauge 、 MIL-STD 、 Powertip Tester 、 Sample
- ◆ Defect Level : Major Defect AQL:0.4 ; Minor Defect AQL:1.5
- ◆ OUT Going Defect Level : Sampling.
- ◆ Standard of the product appearance test:
  - a. Manner of appearance test:
    - (1). The test best be under 20Wx2 fluorescent light , and distance of view must be at 30 cm.
    - (2). The test direction is base on about around 45° of vertical line.

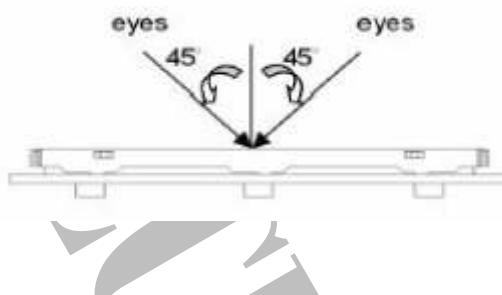

#### (3). Definition of area.

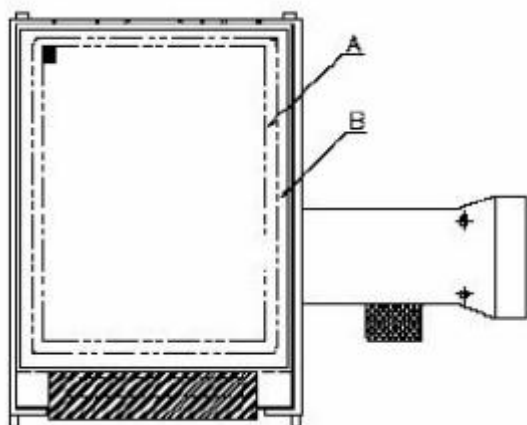

*A* area : viewing area

*B* area : Outside of viewing area

#### (4). Standard of inspection : (Unit: mm)



◆Specification For TFT-LCD Module Less Than 3.5"~10":

(Ver.02)



NO	Item	Criterion	Level												
01	Product condition	1.1 The part number is inconsistent with work order of production.	Major												
		1.2 Mixed product types.	Major												
		1.3 Assembled in inverse direction.	Major												
02	Quantity	2.1 The quantity is inconsistent with work order of production.	Major												
03	Outline dimension	3.1 Product dimension and structure must conform to structure diagram.	Major												
04	Electrical Testing	4.1 Missing line character and icon.	Major												
		4.2 No function of no display.	Major												
		4.3 Display malfunction.	Major												
		4.4 LCD viewing angle defect.	Major												
		4.5 Current consumption exceeds product specifications.	Major												
05	Dot defect (Bright dot, Dark dot)	<table border="1"> <thead> <tr> <th colspan="2">Item</th> <th>Acceptance (Q'ty)</th> </tr> </thead> <tbody> <tr> <td rowspan="4">Dot Defect</td> <td>Bright Dot</td> <td>≤ 4</td> </tr> <tr> <td>Dark Dot</td> <td>≤ 5</td> </tr> <tr> <td>Joint Dot</td> <td>≤ 3</td> </tr> <tr> <td>Total</td> <td>≤ 7</td> </tr> </tbody> </table>	Item		Acceptance (Q'ty)	Dot Defect	Bright Dot	≤ 4	Dark Dot	≤ 5	Joint Dot	≤ 3	Total	≤ 7	Minor
	Item		Acceptance (Q'ty)												
Dot Defect	Bright Dot	≤ 4													
	Dark Dot	≤ 5													
	Joint Dot	≤ 3													
	Total	≤ 7													
On-display	<p>5.1 Inspection pattern: full white, full black, Red, Green and blue screens.</p> <p>5.2 It is defined as dot defect if defect area &gt; 1/2 dot.</p> <p>5.3 The distance between two dot defect ≥ 5 mm.</p>														



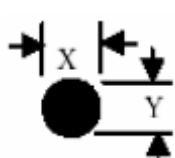

◆Specification For TFT-LCD Module Less Than 3.5"~10":

(Ver.02)

NO	Item	Criterion	Level																												
06	Black or white dot 、 Scratch 、 contamination  Round type  $\Phi = (x+y) / 2$ Line type 	<p>6.1 Round type (Non-display or display) :</p> <table border="1"> <thead> <tr> <th>Dimension (diameter : <math>\Phi</math>)</th> <th>Acceptance (Q'ty)</th> </tr> </thead> <tbody> <tr> <td><math>\Phi \leq 0.25</math></td> <td>Ignore</td> </tr> <tr> <td><math>0.25 &lt; \Phi \leq 0.50</math></td> <td>5</td> </tr> <tr> <td><math>\Phi &gt; 0.50</math></td> <td>0</td> </tr> <tr> <td>Total</td> <td>5</td> </tr> </tbody> </table> <p>6.2 Line type(Non-display or display) :</p> <table border="1"> <thead> <tr> <th>Length(L)</th> <th>Width(W)</th> <th>Acceptance(Q'ty)</th> </tr> </thead> <tbody> <tr> <td>---</td> <td><math>W \leq 0.03</math></td> <td>Ignore</td> </tr> <tr> <td><math>L \leq 10.0</math></td> <td><math>0.03 &lt; W \leq 0.05</math></td> <td>4</td> </tr> <tr> <td><math>L \leq 5.0</math></td> <td><math>0.05 &lt; W \leq 0.10</math></td> <td>2</td> </tr> <tr> <td>--</td> <td><math>W &gt; 0.10</math></td> <td>As round type</td> </tr> <tr> <td colspan="2">Total</td> <td>5</td> </tr> </tbody> </table>	Dimension (diameter : $\Phi$ )	Acceptance (Q'ty)	$\Phi \leq 0.25$	Ignore	$0.25 < \Phi \leq 0.50$	5	$\Phi > 0.50$	0	Total	5	Length(L)	Width(W)	Acceptance(Q'ty)	---	$W \leq 0.03$	Ignore	$L \leq 10.0$	$0.03 < W \leq 0.05$	4	$L \leq 5.0$	$0.05 < W \leq 0.10$	2	--	$W > 0.10$	As round type	Total		5	Minor
Dimension (diameter : $\Phi$ )	Acceptance (Q'ty)																														
$\Phi \leq 0.25$	Ignore																														
$0.25 < \Phi \leq 0.50$	5																														
$\Phi > 0.50$	0																														
Total	5																														
Length(L)	Width(W)	Acceptance(Q'ty)																													
---	$W \leq 0.03$	Ignore																													
$L \leq 10.0$	$0.03 < W \leq 0.05$	4																													
$L \leq 5.0$	$0.05 < W \leq 0.10$	2																													
--	$W > 0.10$	As round type																													
Total		5																													
07	Polarizer  Bubble	<table border="1"> <thead> <tr> <th>Dimension (diameter : <math>\Phi</math>)</th> <th>Acceptance (Q'ty)</th> </tr> </thead> <tbody> <tr> <td><math>\Phi \leq 0.25</math></td> <td>Ignore</td> </tr> <tr> <td><math>0.25 &lt; \Phi \leq 0.50</math></td> <td>4</td> </tr> <tr> <td><math>0.50 &lt; \Phi \leq 0.80</math></td> <td>1</td> </tr> <tr> <td><math>\Phi &gt; 0.80</math></td> <td>0</td> </tr> <tr> <td>Total</td> <td>5</td> </tr> </tbody> </table>	Dimension (diameter : $\Phi$ )	Acceptance (Q'ty)	$\Phi \leq 0.25$	Ignore	$0.25 < \Phi \leq 0.50$	4	$0.50 < \Phi \leq 0.80$	1	$\Phi > 0.80$	0	Total	5	Minor																
Dimension (diameter : $\Phi$ )	Acceptance (Q'ty)																														
$\Phi \leq 0.25$	Ignore																														
$0.25 < \Phi \leq 0.50$	4																														
$0.50 < \Phi \leq 0.80$	1																														
$\Phi > 0.80$	0																														
Total	5																														



◆Specification For TFT-LCD Module Less Than 3.5"~10":

(Ver.02)

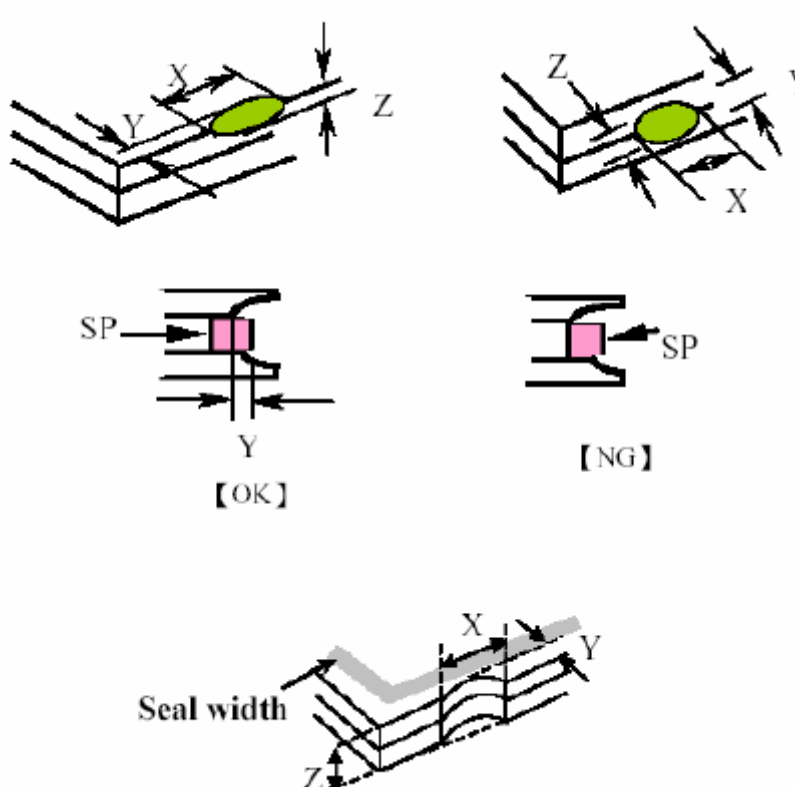
NO	Item	Criterion	Level									
08	The crack of glass	<p>Symbols :</p> <p>X: The length of crack Z: The thickness of crack t : The thickness of glass</p> <p>Y : The width of crack W: terminal length a : LCD side length</p> <p>8.1 General glass chip : 8.1.1 Chip on panel surface and crack between panels:</p>  <table border="1" data-bbox="446 1680 1356 1904"> <thead> <tr> <th>X</th> <th>Y</th> <th>Z</th> </tr> </thead> <tbody> <tr> <td><math>\leq a</math></td> <td>Crack can't enter viewing area</td> <td><math>\leq 1/2 t</math></td> </tr> <tr> <td><math>\leq a</math></td> <td>Crack can't exceed the half of SP width</td> <td><math>1/2 t &lt; Z \leq 2 t</math></td> </tr> </tbody> </table>	X	Y	Z	$\leq a$	Crack can't enter viewing area	$\leq 1/2 t$	$\leq a$	Crack can't exceed the half of SP width	$1/2 t < Z \leq 2 t$	
X	Y	Z										
$\leq a$	Crack can't enter viewing area	$\leq 1/2 t$										
$\leq a$	Crack can't exceed the half of SP width	$1/2 t < Z \leq 2 t$										



◆Specification For TFT-LCD Module 3.5"~10":

(Ver.02)

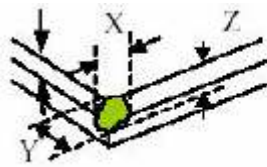
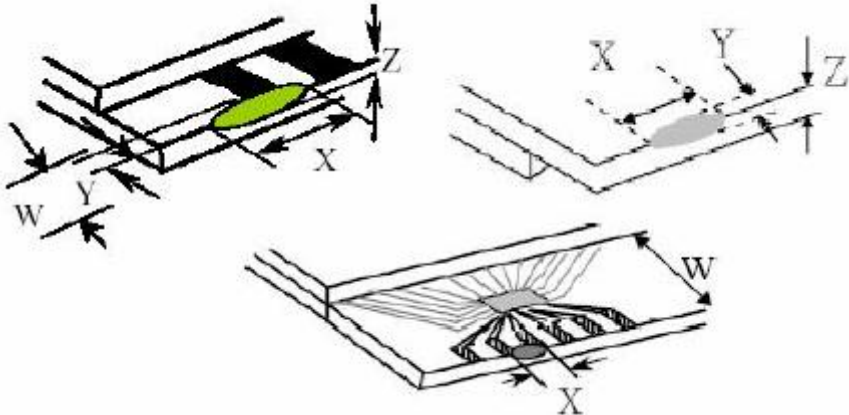
NO	Item	Criterion	Level																					
08	The crack of glass	<p>Symbols :</p> <p>X: The length of crack Z: The thickness of crack t : The thickness of glass</p> <p>Y : The width of crack W: terminal length a : LCD side length</p> <p>8.1.2 Corner crack :</p>  <table border="1" data-bbox="533 931 1382 1160"> <thead> <tr> <th>X</th> <th>Y</th> <th>Z</th> </tr> </thead> <tbody> <tr> <td><math>\leq 1/5 a</math></td> <td>Crack can't enter viewing area</td> <td><math>Z \leq 1/2 t</math></td> </tr> <tr> <td><math>\leq 1/5 a</math></td> <td>Crack can't exceed the half of SP width.</td> <td><math>1/2 t &lt; Z \leq 2 t</math></td> </tr> </tbody> </table> <p>8.2 Protrusion over terminal :</p> <p>8.2.1 Chip on electrode pad :</p>  <table border="1" data-bbox="488 1805 1334 1944"> <thead> <tr> <th></th> <th>X</th> <th>Y</th> <th>Z</th> </tr> </thead> <tbody> <tr> <td>Front</td> <td><math>\leq a</math></td> <td><math>\leq 1/2 W</math></td> <td><math>\leq t</math></td> </tr> <tr> <td>Back</td> <td><math>\leq a</math></td> <td><math>\leq W</math></td> <td><math>\leq 1/2 t</math></td> </tr> </tbody> </table>	X	Y	Z	$\leq 1/5 a$	Crack can't enter viewing area	$Z \leq 1/2 t$	$\leq 1/5 a$	Crack can't exceed the half of SP width.	$1/2 t < Z \leq 2 t$		X	Y	Z	Front	$\leq a$	$\leq 1/2 W$	$\leq t$	Back	$\leq a$	$\leq W$	$\leq 1/2 t$	Minor
X	Y	Z																						
$\leq 1/5 a$	Crack can't enter viewing area	$Z \leq 1/2 t$																						
$\leq 1/5 a$	Crack can't exceed the half of SP width.	$1/2 t < Z \leq 2 t$																						
	X	Y	Z																					
Front	$\leq a$	$\leq 1/2 W$	$\leq t$																					
Back	$\leq a$	$\leq W$	$\leq 1/2 t$																					



◆Specification For TFT-LCD Module 3.5"~10":

(Ver.02)

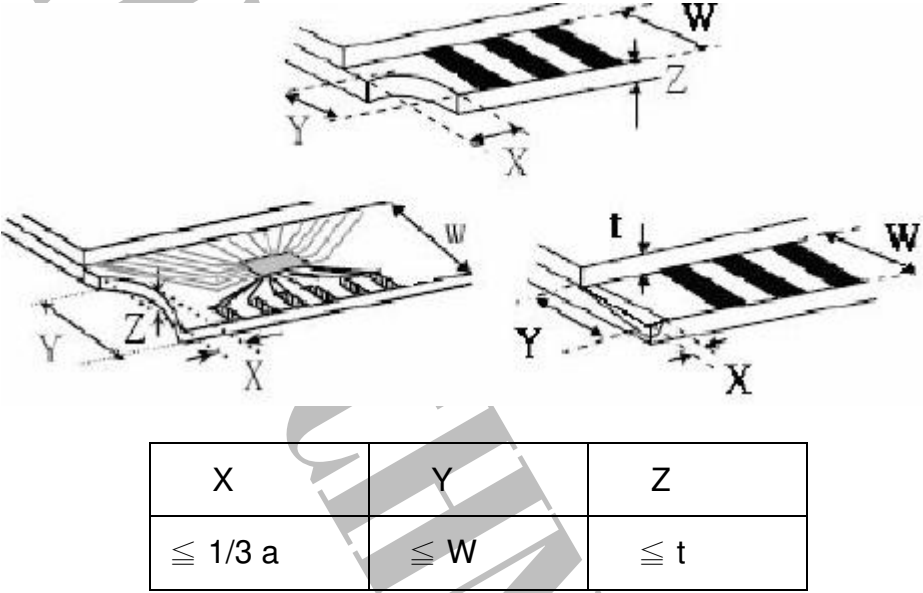
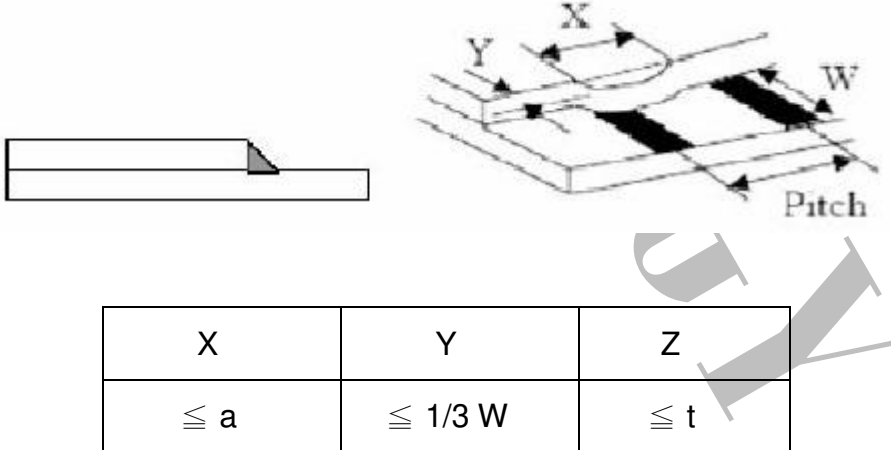
NO	Item	Criterion	Level
08	The crack of glass	<p>Symbols :</p> <p>X: The length of crack Z: The thickness of crack t : The thickness of glass</p> <p>Y : The width of crack W: terminal length a : LCD side length</p> <p>8.2.2 Non-conductive portion :</p>  <p>⊙ If the chipped area touches the ITO terminal, over 2/3 of the ITO must remain and be inspected according to electrode terminal specifications.</p> <p>8.2.3 Glass remain :</p> 	Minor



◆Specification For TFT-LCD Module 3.5"~10":

(Ver.02)

NO	Item	Criterion	Level
09	Backlight elements	9.1 Backlight can't work normally.	Major
		9.2 Backlight doesn't light or color is wrong.	Major
		9.3 Illumination source flickers when lit.	Major
10	General appearance	10.1 Pin type · quantity · dimension must match type in structure diagram.	Major
		10.2 No short circuits in components on PCB or FPC.	Major
		10.3 Parts on PCB or FPC must be the same as on the production characteristic chart. There should be no wrong parts, missing parts or excess parts.	Major
		10.4 Product packaging must the same as specified on packaging specification sheet.	Minor
		10.5 The folding and peeled off in polarizer are not acceptable.	Minor
		10.6 The PCB or FPC between B/L assembled distance(PCB or FPC)is $\leq 1.5\text{mm}$ .	Minor



## 4. RELIABILITY TEST

### 4.1 Reliability Test Condition

(Ver.02)

No	TEST ITEM	TEST CONDITION										
1	High Temperature Storage Test	Keep in +80 ±20°C 96hrs Surrounding temperature, then storage at normal condition 4hrs.										
2	Low Temperature Storage Test	Keep in -30 ±20°C 96hrs Surrounding temperature, then storage at normal condition 4hrs.										
3	High Temperature/High Humidity Storage Test	Keep in +60°C / 90% R.H duration for 96hrs Surrounding temperature, then storage at normal condition 4hrs.(Excluding the polarizer & T/P)										
4	ESD Test	Air Discharge: Apply 2 KV with 5 times Discharge for each polarity +/-										
		Contact Discharge: Apply 250V with 5 times Discharge for each polarity +/-										
		1. Temperature ambience : 15°C ~35°C 2. Humidity relative : 30% ~ 60% 3. Energy Storage Capacitance (Cs+Cd) : 150pF±10% 4. Discharge Resistance (Rd) : 330Ω±10% 5. Discharge, mode of operation: Single Discharge(time between successive discharges at least 1 sec) (Tolerance if the output voltage indication : ±5%)										
5	Temperature Cycling Storage Test	-20°C → +25°C → +70°C → +25°C (30mins) (5mins) (30mins) (5mins) ←-----→ 10 Cycle Surrounding temperature, then storage at normal condition 4hrs.										
6	Vibration Test (Packaged)	1. Sine wave 10~55 Hz frequency(1 min) 2. The amplitude of vibration : 1.5mm 3. Each direction (X、Y、Z)duration for 2 hrs										
7	Drop Test (Packaged)	<table border="1"> <thead> <tr> <th>Packing Weight (Kg)</th> <th>Drop Height (cm)</th> </tr> </thead> <tbody> <tr> <td>0 ~ 45.4</td> <td>122</td> </tr> <tr> <td>45.4 ~ 90.8</td> <td>76</td> </tr> <tr> <td>90.8 ~ 454</td> <td>61</td> </tr> <tr> <td>Over 454</td> <td>46</td> </tr> </tbody> </table>	Packing Weight (Kg)	Drop Height (cm)	0 ~ 45.4	122	45.4 ~ 90.8	76	90.8 ~ 454	61	Over 454	46
		Packing Weight (Kg)	Drop Height (cm)									
0 ~ 45.4	122											
45.4 ~ 90.8	76											
90.8 ~ 454	61											
Over 454	46											
		Drop direction : * 1 corner / 3 edges / 6 sides each 1 times										





## 5. RECAUTION RELATING PRODUCT HANDLING

### 5.1 SAFETY

If the LCD panel breaks, be careful not to get the liquid crystal to touch your skin.

If the liquid crystal touches your skin or clothes, please wash it off immediately by using soap and water.

### 5.2 HANDLING

5.2.1 Avoid any strong mechanical shock which can break the glass.

5.2.2 Avoid static electricity which can damage the CMOS LSI-When working with the module, be sure to ground your body and any electrical equipment you may be using.

5.2.3 Do not remove the panel of frame from the module.

5.2.4 The polarizing plate of the display is very fragile. So, please handle it very carefully, do not touch, push or rub the exposed polarizing with anything harder than an HB pencil lead (glass, tweezers, etc.)

5.2.5 Do not wipe the polarizing plate with a dry cloth, as it may easily scratch the surface of plate.

5.2.6 Do not touch the display area with bare hands, this will stain the display area.

5.2.7 Do not use ketonics solvent & aromatic solvent. Use with a soft cloth soaked with a cleaning naphtha solvent.

5.2.8 To control temperature and time of soldering is  $320\pm 10^{\circ}\text{C}$  and 3-5 sec.

5.2.9 To avoid liquid(include organic solvent) stained on LCM

### 5.3 STORAGE

5.3.1 Store the panel or module in a dark place where the temperature is  $25^{\circ}\text{C}\pm 5^{\circ}\text{C}$  and the humidity is below 65%RH.

5.3.2 Do not place the module near organics solvents or corrosive gases.

5.3.3 Do not crush, shake, or jolt the module.

### 5.4 TERMS OF WARRANTY

5.4.1 Applicable warrant period

The period is within thirteen months since the date of shipping out under normal using and storage conditions.

5.4.2 Unaccepted responsibility

This product has been manufactured to your company's specification as a part for use in your company's general electronic products. It is guaranteed to perform according to delivery specifications. For any other use apart from general electronic equipment, we cannot take responsibility if the product is used in nuclear power control equipment, aerospace equipment, fire and security systems or any other applications in which there is a direct risk to human life and where extremely high levels of reliability are required.





## OUTLINE DRAWING

