

PART NUMBER	REVISION	DESCRIPTION	FEED TYPE
2151261-1	C	FINE CRIMP HEIGHT ADJUST	MECHANICAL
2151261-2	D	FINE CRIMP HEIGHT ADJUST	PNEUMATIC
7-2151261-1	C	MECHANICAL AND CRIMP TOOLING KIT	MECHANICAL
7-2151261-2	D	PNEUMATIC AND CRIMP TOOLING KIT	PNEUMATIC
7-2151261-7	A	CRIMP TOOLING KIT	-

ATLANTIC VERSION TERMINATOR INTERFACE ADAPTER

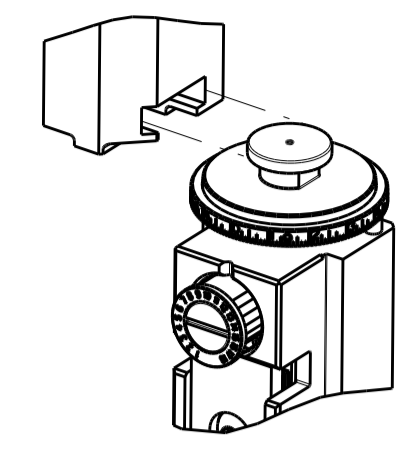

APPLICATOR DATA		
CRIMP	SIZE	TYPE
WIRE	2.29 mm [.090]	F
INSUL	3.56 mm [.140]	F

APPLICATOR INSTRUCTIONS 408-35042

TERMINAL DATA: TE TERMINAL		TE CRIMP SPECIFICATION	
TERMINAL NAME: STANDARD TIMER CONTACT			
WIRE STRIP LENGTH		INSULATION DIAMETER RANGE	
4.30-4.90 mm [.169-.193 IN]		Ø2.00-3.00 mm [.079-.118 IN]	
TERMINAL APPLICATION SPECIFICATION	114-18080		
TERMINALS APPLIED			
TE TERMINAL	TE TERMINAL	TE TERMINAL	TE TERMINAL
925575-1	925575-2	3-925575-1	3-925575-2

TERMINAL DATA: TE TERMINAL		TE CRIMP SPECIFICATION	
TERMINAL NAME: STANDARD TIMER CONTACT			
WIRE STRIP LENGTH		INSULATION DIAMETER RANGE	
4.30-4.90 mm [.169-.193 IN]		Ø2.00-3.00 mm [.079-.118 IN]	
TERMINAL APPLICATION SPECIFICATION	114-18080		
TERMINALS APPLIED			
TE TERMINAL	TE TERMINAL	TE TERMINAL	TE TERMINAL
926965-1	926965-2	3-926965-1	969036-4

WIRE SIZE	CRIMP HEIGHT mm [INCH]	CRIMP HEIGHT REFERENCE SETTING
1.50mm2	1.44+/-0.05 [.057+/-0.002]	9.7
1.00mm2	1.38+/-0.05 [.054+/-0.002]	10.3

WIRE SIZE	CRIMP HEIGHT mm [INCH]	CRIMP HEIGHT REFERENCE SETTING
1.50mm2	1.44+/-0.05 [.057+/-0.002]	9.7
1.25mm2	1.41+/-0.05 [.056+/-0.002]	10.0
1.00mm2	1.38+/-0.05 [.054+/-0.002]	10.3
0.75mm2	1.34+/-0.05 [.053+/-0.002]	10.7
0.50mm2	1.30+/-0.05 [.051+/-0.002]	11.1

- RECOMMENDED SPARE PARTS
- REFER TO SUPPLIED INSTRUCTION SHEET FOR CLEANING, LUBRICATION AND STORAGE OF APPLICATOR.
- APPLY PART NUMBER 2-23419-6 LOCTITE TO THREADS OF ITEM 242.
- CRIMP HEIGHT REFERENCE SETTING WAS THE SETTING USED WHEN THE APPLICATOR WAS QUALIFIED AT THE FACTORY. ADJUSTMENT MAY BE NECESSARY WHEN RUNNING APPLICATOR IN THE FIELD.
- 5. UNLESS SPECIFIED OTHERWISE TORQUE VALUES SHALL BE USED PER DOCUMENT, 101-35000.

**\*WARNING**  
ON INSTALLATION, SET WIRE DISC TO CRIMP HEIGHT REFERENCE SETTING FOR LARGEST WIRE SIZE. CRIMP HEIGHT REFERENCE SETTINGS GREATER THAN THE VALUE SHOWN MAY CAUSE DAMAGE TO THE CRIMP TOOLING. REFER TO THE INSTRUCTION SHEET FOR PROPER SETUP AND ADJUSTMENTS.

ATLANTIC VERSION  
Shown on sheets 1 of 4 & 2 of 4  
(Pacific version shown on sheets 3 of 4 & 4 of 4)

LOC	DIST	REVISIONS			
A	66	REV	DATE	BY	APPV
		B	ECR-13-008460	23MAY2013	X.Z T.E
		B1	ECR-17-015961	30OCT2017	KH JDG
		C	ECR-18-008119	26MAY2018	TB JDG
		D	ECR-20-016831	26NOV2020	FZ TE

-	1	-	1	-	2119641-1	FEED CAM, AIR FEED	248
-	1	1	1	1	2119082-9	CAM, SNAIL, INSULATION ADJUSTMENT	244
-	1	1	1	1	2079764-1	WASHER, WAVE SPRING, CREST-TO-CREST	243
-	1	1	1	1	2119083-1	RETAINER, INSULATION DIAL	242
-	1	1	1	1	18023-1	SCR, SKT HD CAP M3 X 5.0	241
-	-	1	-	1	2119580-1	MECHANICAL FEED ASSEMBLY	239
-	1	-	1	-	2844940-1	AIR FEED MODULE	238
-	REF	REF	REF	REF	994970-2	COUNTER, MAGNETIC	164
-	1	1	1	1	1-18028-2	WASHER, FLAT, REG M4	119
-	1	1	1	1	2844908-1	SCREW, LOCKING	99
-	1	1	1	1	2844907-1	POST, LOCKING	98
-	1	1	1	1	455888-4	SPACER, CRIMPER	82
-	1	1	1	1	1803607-3	DOCUMENTATION PACKAGE	71
-	1	1	1	1	2119740-1	TAG, IDENTIFICATION	67
-	2	2	2	2	2168078-1	SCREW, DRIVE, RH, RoHS, 2 x .188	66
-	1	1	1	1	2168083-2	SCR, SKT HD CAP, RoHS, M4 X 8.0	60
-	1	1	1	1	5-18022-5	SCR, HEX HD CAP, M4 X 6.0	59
-	1	1	1	1	1338685-1	PAWL, FEED	56
-	4	4	4	4	2168083-3	SCR, SKT HD CAP, RoHS, M4 X 12.0	54
-	2	2	2	2	2168083-3	SCR, SKT HD CAP, RoHS, M4 X 12.0	53
-	1	1	1	1	1803382-6	HOLD DOWN, SPRING LOADED	50
-	1	2	1	2	18023-9	SCR, SKT HD CAP M4 X 6.0	49
-	-	1	-	1	2119652-1	FEED CAM, PRE FEED	48
-	-	1	-	1	2119653-1	FEED CAM, POST FEED	47
-	1	1	1	1	1803583-9	APPLICATOR BASIC ASSEMBLY, SF	46
-	1	1	1	1	1803515-1	RAM ASSEMBLY, SF ATLANTIC	44
-	1	1	1	1	1803602-1	SCR, BHSC, RoHS (M8 X 25)	41
-	1	1	1	1	1752356-3	SUPPORT, TERMINAL	34
-	2	2	2	2	2079383-5	SCR, BHSC, RoHS (M4 X 20)	33
-	2	2	2	2	2-2844962-6	SPACER, CYLINDRICAL, STRIP GUIDE	30
-	1	1	1	1	2844992-1	ASSEMBLY, STRIP GUIDE	29
-	1	1	1	1	1-455888-0	SPACER, CRIMPER	28
-	1	1	1	1	1320928-2	STRIP GUIDE	24
-	1	1	1	1	2168083-2	SCR, SKT HD CAP, RoHS, M4 X 8.0	21
-	1	1	1	1	1-18028-2	WASHER, FLAT, REG M4	20
-	1	1	1	1	2119533-1	STRIPPER, SIDE FEED	19
-	1	1	1	1	2119806-1	INSERT, SHEAR	13
-	1	1	1	1	3-22280-3	SPRING, COMPRESSION	12
-	1	1	1	1	1-356885-4	STOP, SHEAR	11
-	1	1	1	1	2119805-1	SHEAR HOLDER, FRONT	10
-	1	1	1	1	454276-5	FLOATING SHEAR, FRONT	9
-	1	2	2	1	1333205-1	ANVIL, COMBINATION	8
-	1	1	1	1	1-240641-3	SPACER	7
-	1	1	1	1	2119757-4	DEPRESSOR, SHEAR	5
-	1	1	1	1	238011-8	BLOCK, CRIMPER SPACER	4
-	1	2	2	1	2-2119582-4	CRIMPER, INSULATION F PREMIUM	3
-	1	1	1	1	455888-6	SPACER, CRIMPER	2
-	1	2	2	1	3-456406-0	CRIMPER, WIRE PREMIUM	1

DIMENSIONS:		TOLERANCES UNLESS OTHERWISE SPECIFIED:		MATERIAL:		FINISH:		WEIGHT:		SCALE:	
mm	0 PLC	±									
	1 PLC	±									
	2 PLC	±									
	3 PLC	±									
	4 PLC	±									
	ANGLES	±									

LOC		DIST		REVISIONS			
NO.	REV.	DATE	BY	DESCRIPTION	DATE	BY	APPROV.
A	66	-	-	SEE SHEET 1	-	-	-

# FEED TYPE MECHANICAL

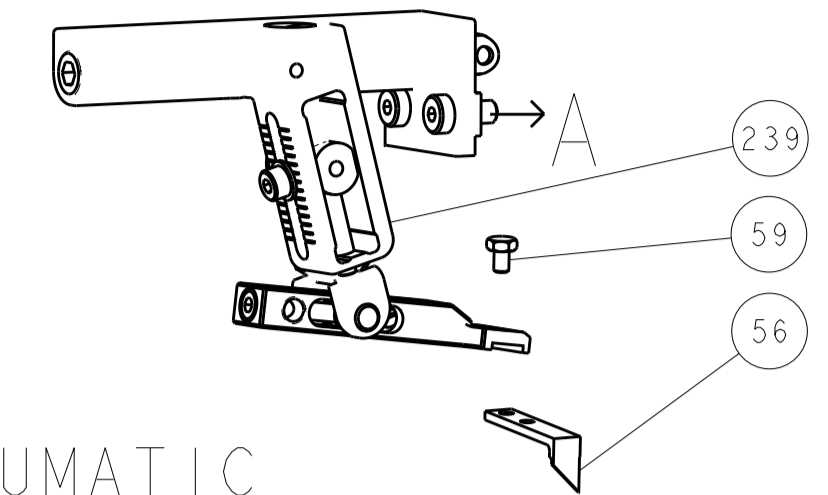

## PNEUMATIC

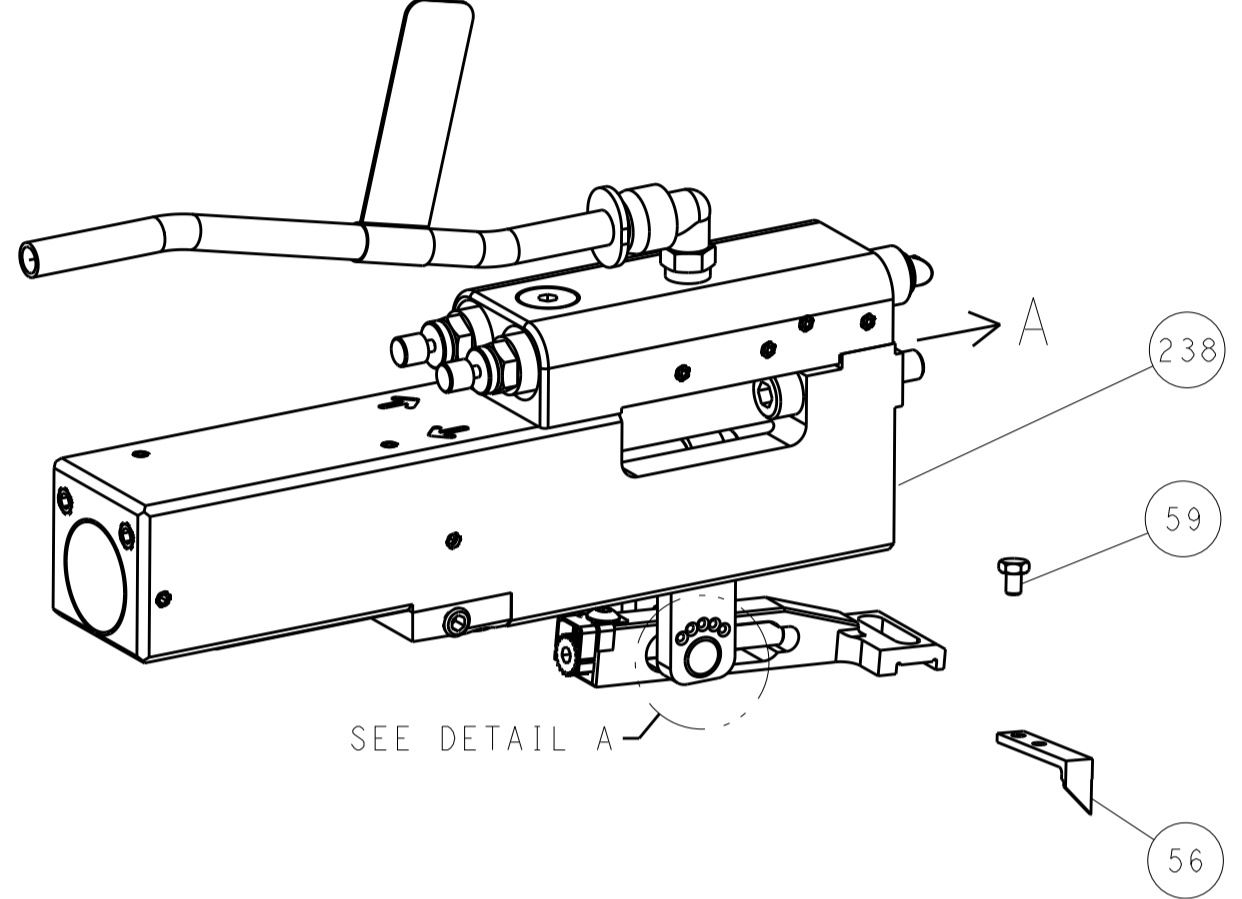

## FEED SPRING SETTING POSITION (SHOWN FROM REAR SIDE)

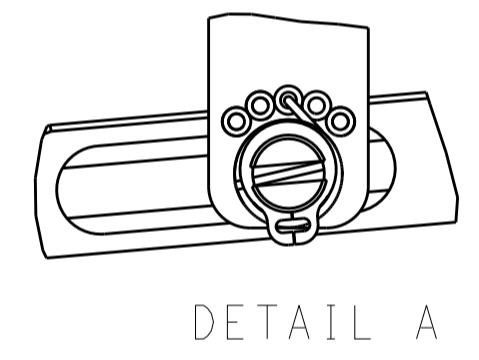

DETAIL A

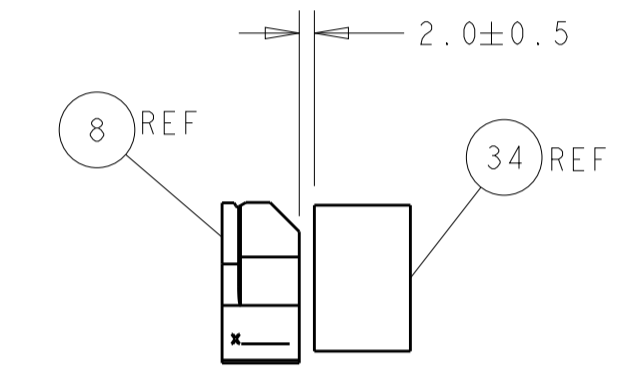
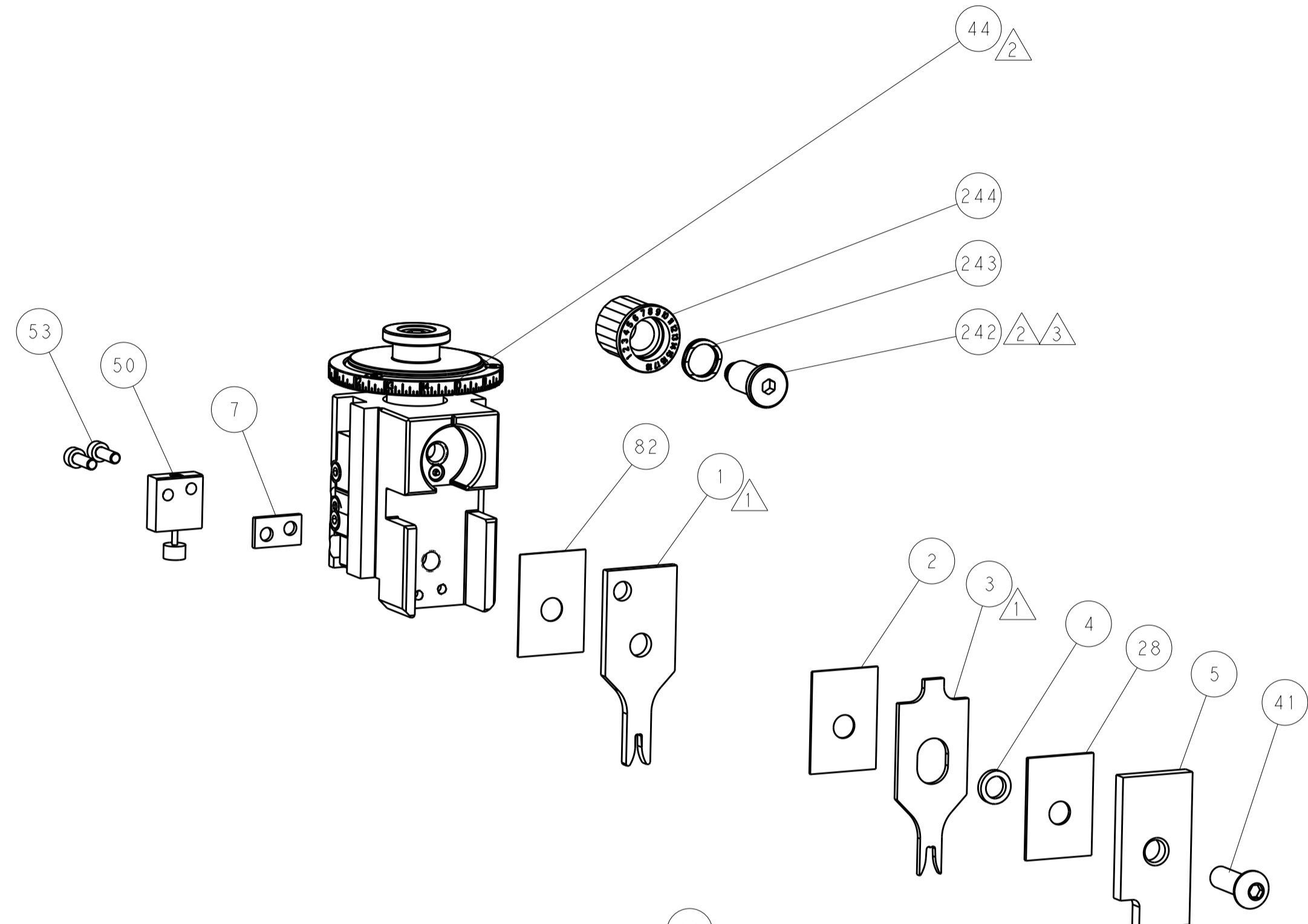

TERMINAL SUPPORT LOCATION

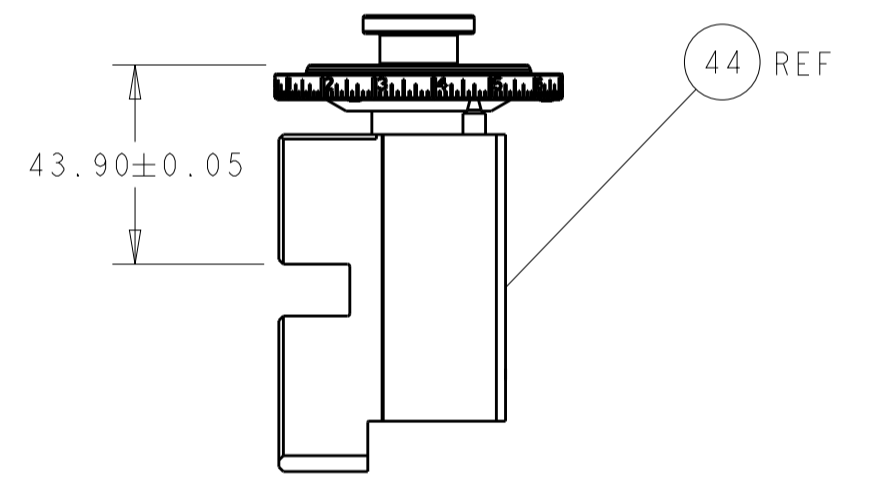

RAM SET-UP

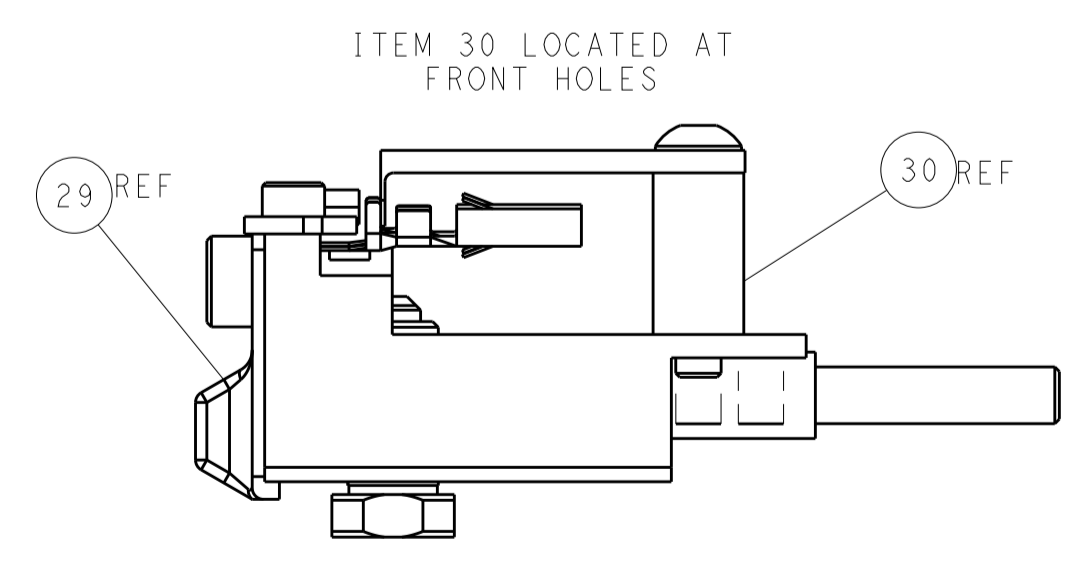
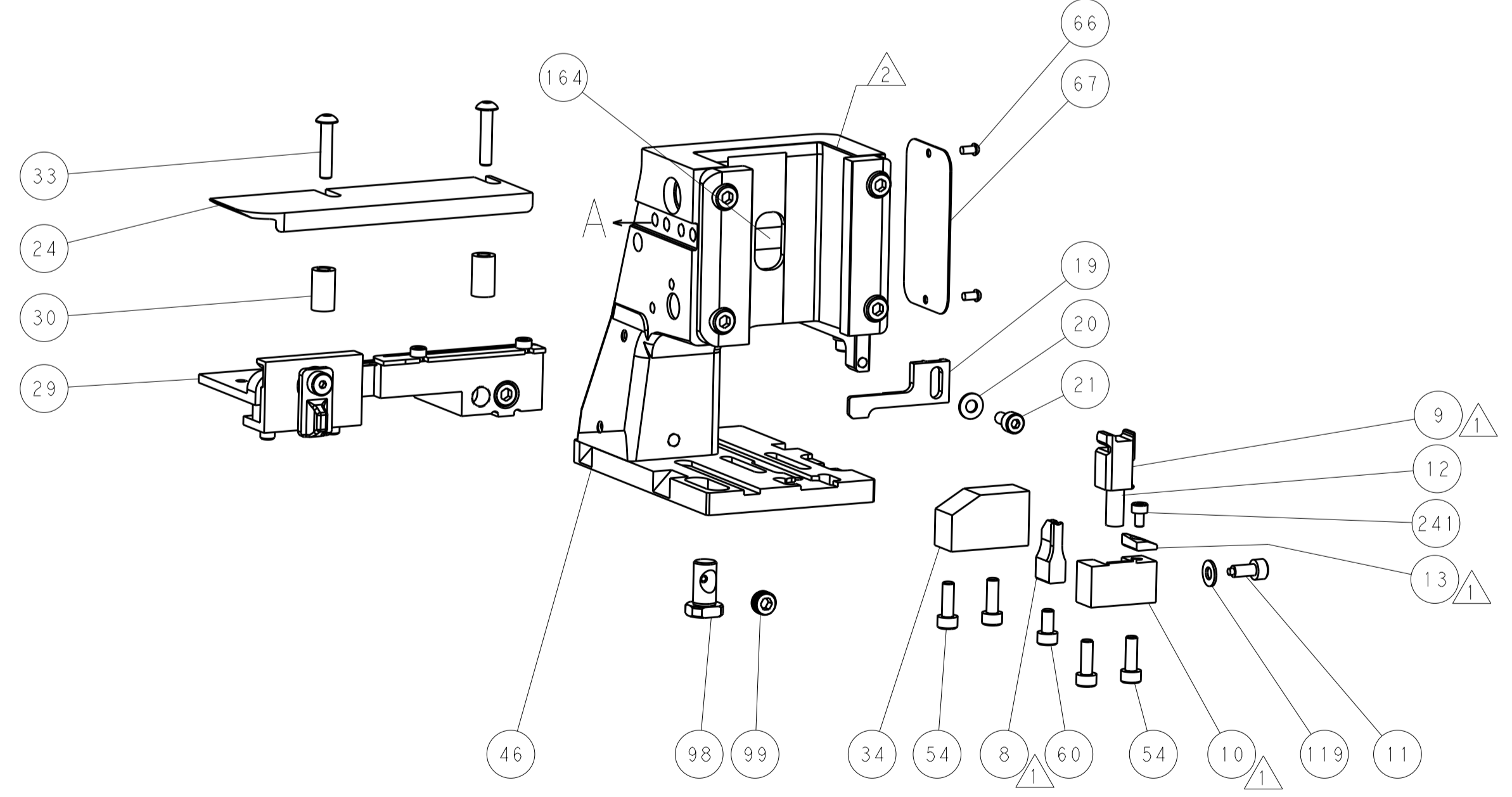

FEED TRACK POSITION GUIDE BY INSULATION BARREL

# CAM POSITIONS

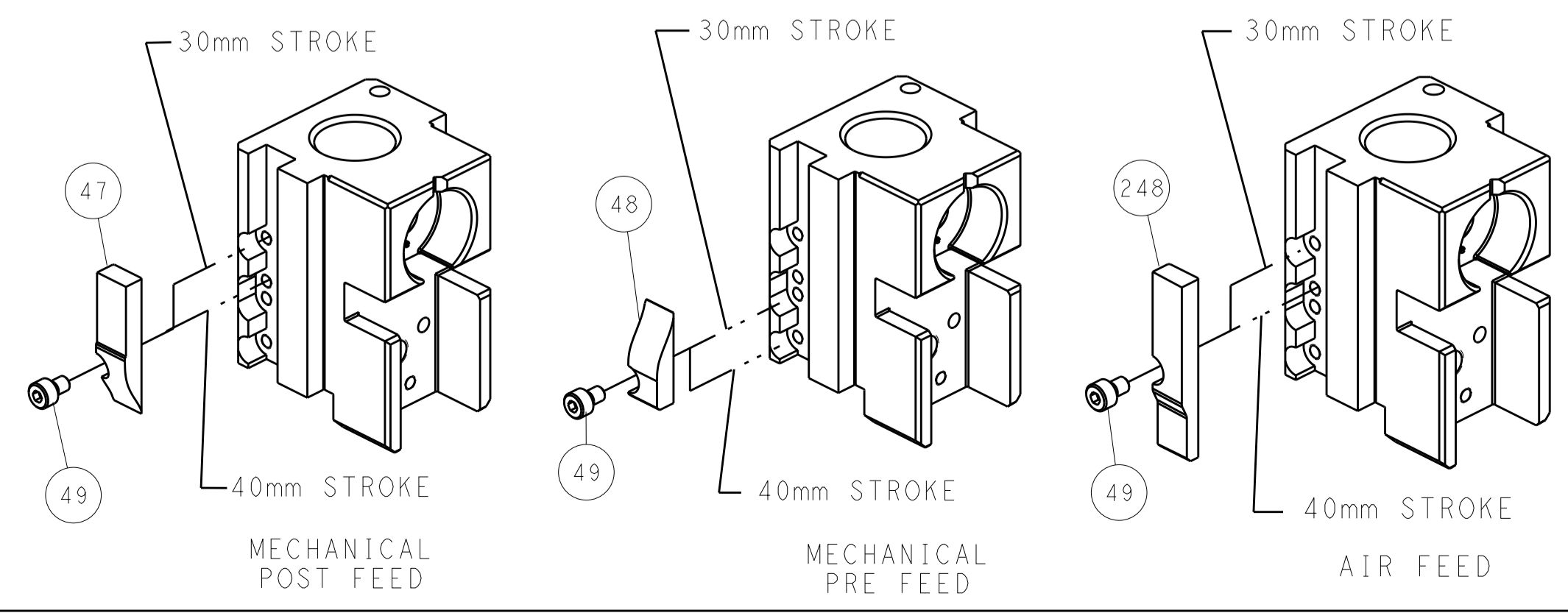

**ATLANTIC VERSION**  
 Shown on sheets 1 of 4 & 2 of 4  
 (Pacific version shown on sheets 3 of 4 & 4 of 4)

DIMENSIONS:		TOLERANCES UNLESS OTHERWISE SPECIFIED:		DWN L. ZHANG 17OCT2011		TE Connectivity	
mm	0 PLC ±	1 PLC ±	2 PLC ±	3 PLC ±	4 PLC ±	Harrisburg, PA 17105-3608	
MATERIAL:		FINISH:		CHK L. ZHANG 17OCT2011		NAME Ocean Side Feed Applicator	
				S. XI 17OCT2011		SIZE CAGE CODE DRAWING NO	
				APVD		RESTRICTED TO	
				PRODUCT SPEC		A1 00779 ©=2151261	
				APPLICATION SPEC		SCALE 1:2 SHEET 2 OF 4 REV D	
				WEIGHT		Customer Accessible Production Drawing	

PART NUMBER	REVISION	DESCRIPTION	FEED TYPE
2-2151261-1	C	FINE CRIMP HEIGHT ADJUST	MECHANICAL
2-2151261-2	D	FINE CRIMP HEIGHT ADJUST	PNEUMATIC
7-2151261-7	A	CRIMP TOOLING KIT	-

PACIFIC VERSION TERMINATOR  
INTERFACE ADAPTER



APPLICATOR DATA		
CRIMP	SIZE	TYPE
WIRE	2.29 mm [.090]	F
INSUL	3.56 mm [.140]	F

APPLICATOR INSTRUCTIONS  
408-35042

TERMINAL DATA: TE TERMINAL		TE CRIMP SPECIFICATION	
TERMINAL NAME: STANDARD TIMER CONTACT			
WIRE STRIP LENGTH		INSULATION DIAMETER RANGE	
4.30-4.90 mm [.169-.193 IN]		∅2.00-3.00 mm [.079-.118 IN]	
TERMINAL APPLICATION SPECIFICATION	114-18080	-	-
TERMINALS APPLIED			
TE TERMINAL	TE TERMINAL	TE TERMINAL	TE TERMINAL
925575-1	925575-2	3-925575-1	3-925575-2

TERMINAL DATA: TE TERMINAL		TE CRIMP SPECIFICATION	
TERMINAL NAME: STANDARD TIMER CONTACT			
WIRE STRIP LENGTH		INSULATION DIAMETER RANGE	
4.30-4.90 mm [.169-.193 IN]		∅2.00-3.00 mm [.079-.118 IN]	
TERMINAL APPLICATION SPECIFICATION	114-18080	-	-
TERMINALS APPLIED			
TE TERMINAL	TE TERMINAL	TE TERMINAL	TE TERMINAL
926965-1	926965-2	3-926965-1	969036-4
3-969036-4			

WIRE SIZE	CRIMP HEIGHT mm [INCH]	CRIMP HEIGHT REFERENCE SETTING
1.50mm2	1.44 +/- 0.05 [.057 +/- .002]	9.7
1.00mm2	1.38 +/- 0.05 [.054 +/- .002]	10.3

WIRE SIZE	CRIMP HEIGHT mm [INCH]	CRIMP HEIGHT REFERENCE SETTING
1.50mm2	1.44 +/- 0.05 [.057 +/- .002]	9.7
1.25mm2	1.41 +/- 0.05 [.056 +/- .002]	10.0
1.00mm2	1.38 +/- 0.05 [.054 +/- .002]	10.3
0.75mm2	1.34 +/- 0.05 [.053 +/- .002]	10.7
0.50mm2	1.30 +/- 0.05 [.051 +/- .002]	11.1

- RECOMMENDED SPARE PARTS
- REFER TO SUPPLIED INSTRUCTION SHEET FOR CLEANING, LUBRICATION AND STORAGE OF APPLICATOR.
- APPLY PART NUMBER 2-23419-6 LOCTITE TO THREADS OF ITEM 242.
- CRIMP HEIGHT REFERENCE SETTING WAS THE SETTING USED WHEN THE APPLICATOR WAS QUALIFIED AT THE FACTORY. ADJUSTMENT MAY BE NECESSARY WHEN RUNNING APPLICATOR IN THE FIELD.
- 5. UNLESS SPECIFIED OTHERWISE TORQUE VALUES SHALL BE USED PER DOCUMENT, 101-35000.

**\*WARNING**  
ON INSTALLATION, SET WIRE DISC TO CRIMP HEIGHT REFERENCE SETTING FOR LARGEST WIRE SIZE. CRIMP HEIGHT REFERENCE SETTINGS GREATER THAN THE VALUE SHOWN MAY CAUSE DAMAGE TO THE CRIMP TOOLING. REFER TO THE INSTRUCTION SHEET FOR PROPER SETUP AND ADJUSTMENTS.

LOC	DIST	REV	DATE	BY	APPV
A	66	-	-	-	-

REV	DATE	BY	APPV	DESCRIPTION	ITEM NO	
-	1	1		2119082-9	CAM, SNAIL, INSULATION ADJUSTMENT	244
-	1	1		2079764-1	WASHER, WAVE SPRING, CREST-TO-CREST	243
-	1	1		2119083-1	RETAINER, INSULATION DIAL	242
-	1	1		18023-1	SCR, SKT HD CAP M3 X 5.0	241
-	-	1		2119580-1	MECHANICAL FEED ASSEMBLY	239
-	1	-		2844940-1	AIR FEED MODULE	238
-	REF	REF		994970-2	COUNTER, MAGNETIC	164
-	1	-		2119641-2	FEED CAM, AIR FEED	151
-	1	1		2168083-8	SCR, SKT HD CAP, RoHS, M4 X 16	144
-	4	4		2168083-9	SCR, SKT HD CAP, RoHS, M4 X 20	143
-	-	1		2119653-2	FEED CAM, POST FEED	142
-	1	1		1-1803583-0	APPLICATOR BASIC ASSEMBLY, SF	141
-	1	1		1803516-1	RAM ASSEMBLY, SF PACIFIC	140
-	1	1		1-18028-2	WASHER, FLAT, REG M4	119
-	1	1		2844908-1	SCREW, LOCKING	99
-	1	1		2844907-1	POST, LOCKING	98
-	1	1		455888-4	SPACER, CRIMPER	82
-	1	1		1803607-3	DOCUMENTATION PACKAGE	71
-	1	1		2119740-1	TAG, IDENTIFICATION	67
-	2	2		2168078-1	SCREW, DRIVE, RH, RoHS, 2 x .188	66
-	1	1		5-18022-5	SCR, HEX HD CAP, M4 X 6.0	59
-	1	1		1338685-1	PAWL, FEED	56
-	2	2		2168083-3	SCR, SKT HD CAP, RoHS, M4 X 12.0	53
-	1	1		1803382-6	HOLD DOWN, SPRING LOADED	50
-	1	2		18023-9	SCR, SKT HD CAP M4 X 6.0	49
-	-	1		2119652-1	FEED CAM, PRE FEED	48
-	1	1		1803602-1	SCR, BHSC, RoHS (M8 X 25)	41
-	1	1		1752356-3	SUPPORT, TERMINAL	34
-	2	2		2079383-5	SCR, BHSC, RoHS (M4 X 20)	33
-	2	2		2-2844962-6	SPACER, CYLINDRICAL, STRIP GUIDE	30
-	1	1		2844992-1	ASSEMBLY, STRIP GUIDE	29
-	1	1		1-455888-0	SPACER, CRIMPER	28
-	1	1		1320928-2	STRIP GUIDE	24
-	1	1		2168083-2	SCR, SKT HD CAP, RoHS, M4 X 8.0	21
-	1	1		1-18028-2	WASHER, FLAT, REG M4	20
-	1	1		2119533-1	STRIPPER, SIDE FEED	19
-	1	1		2119806-1	INSERT, SHEAR	13
-	1	1		3-22280-3	SPRING, COMPRESSION	12
-	1	1		1-356885-4	STOP, SHEAR	11
-	1	1		2119805-1	SHEAR HOLDER, FRONT	10
-	1	1		454276-5	FLOATING SHEAR, FRONT	9
-	1	1		1333205-1	ANVIL, COMBINATION	8
-	1	1		1-240641-3	SPACER	7
-	1	1		2119757-4	DEPRESSOR, SHEAR	5
-	1	1		238011-8	BLOCK, CRIMPER SPACER	4
-	1	1		2-2119582-4	CRIMPER, INSULATION F PREMIUM	3
-	1	1		455888-6	SPACER, CRIMPER	2
-	1	1		3-456406-0	CRIMPER, WIRE PREMIUM	1
-	77	-22	-21	PART NO	DESCRIPTION	ITEM NO

PACIFIC VERSION  
Shown on sheets 3 of 4 & 4 of 4  
(Atlantic version shown on sheets 1 of 4 & 2 of 4)

DIMENSIONS:		TOLERANCES UNLESS OTHERWISE SPECIFIED:		DWG: L. ZHANG 11OCT2011		CHK: L. ZHANG 11OCT2011		APVD: S. XI 11OCT2011		NAME: Ocean Side Feed Applicator	
mm	0 PLC ±	1 PLC ±	2 PLC ±	3 PLC ±	4 PLC ±	ANGLES	FINISH	WEIGHT	SCALE: 1:2	SHEET 3 OF 4	REV D
MATERIAL:								Customer Accessible Production Drawing		RESTRICTED TO:	

LOC		DIST		REVISIONS			
A	66	P	LTM	DESCRIPTION	DATE	DWN	APVD
		-		SEE SHEET 1			

# FEED TYPE MECHANICAL

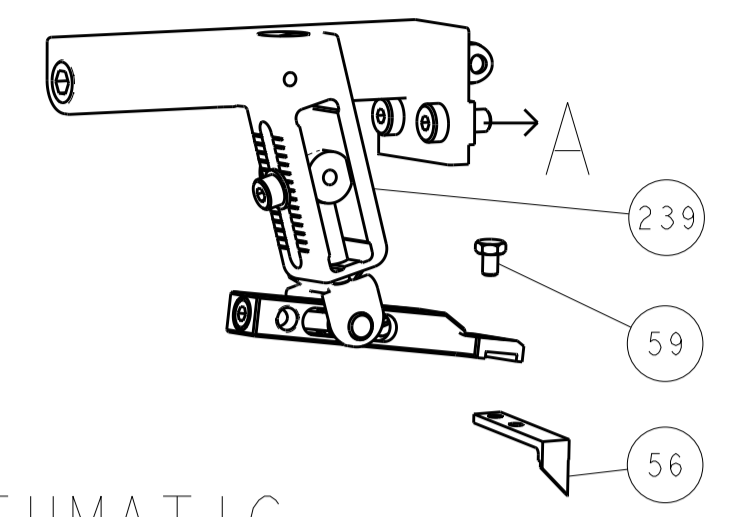

## PNEUMATIC

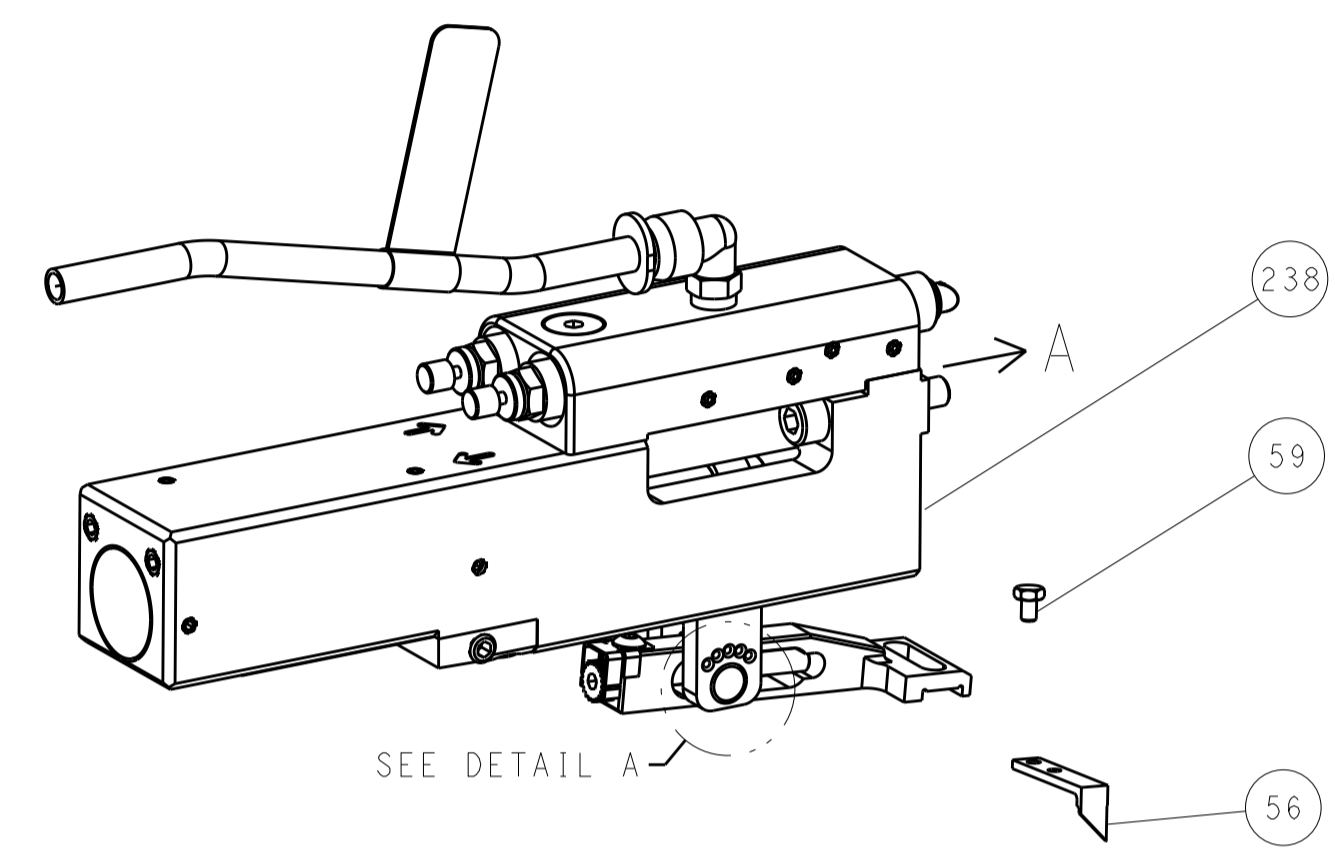

### FEED SPRING SETTING POSITION (SHOWN FROM REAR SIDE)

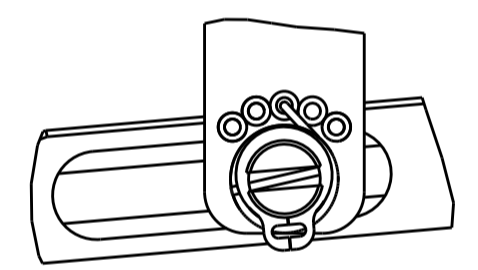

DETAIL A

# CAM POSITIONS

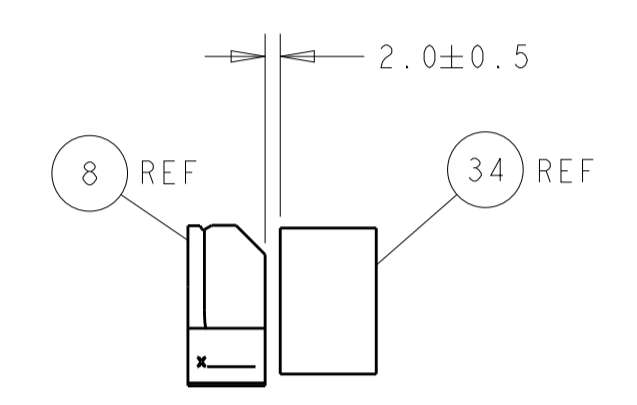
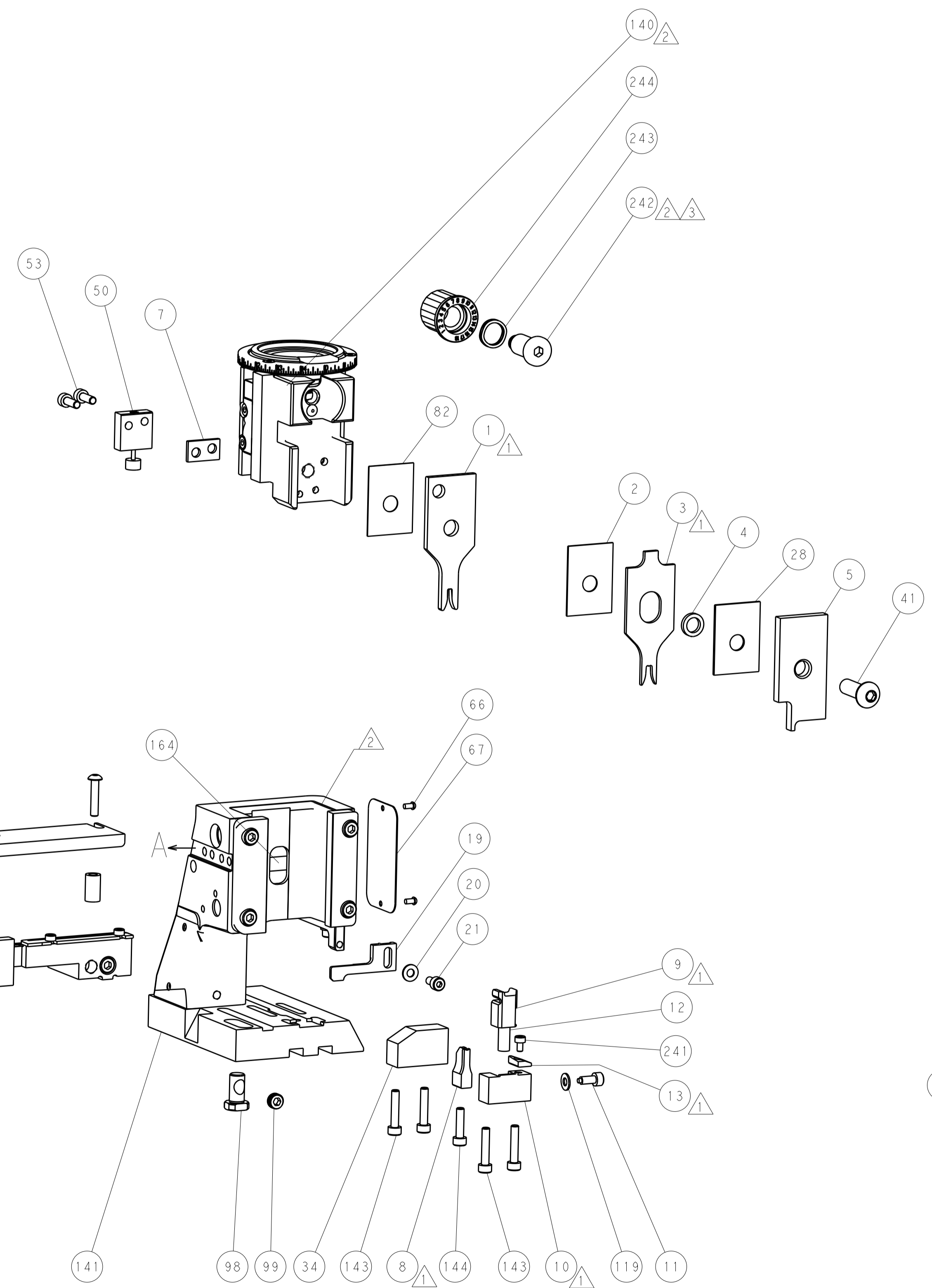
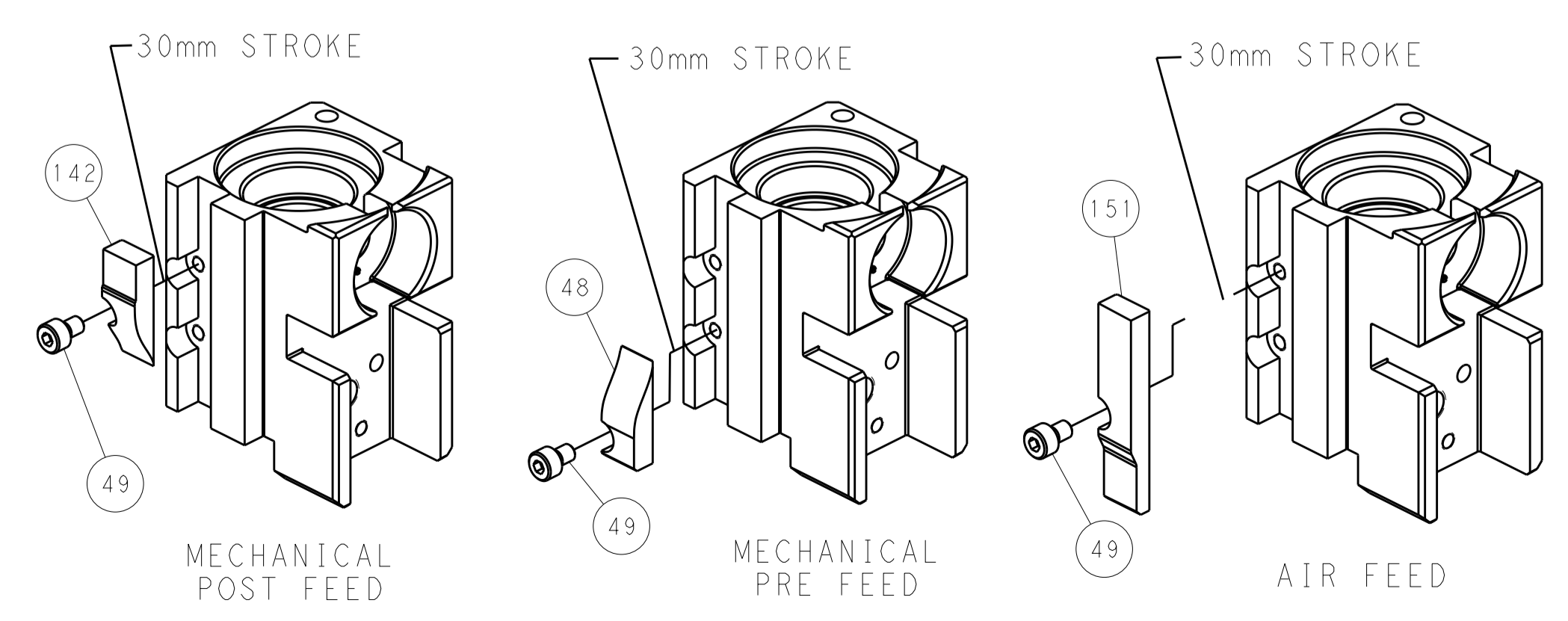

TERMINAL SUPPORT LOCATION

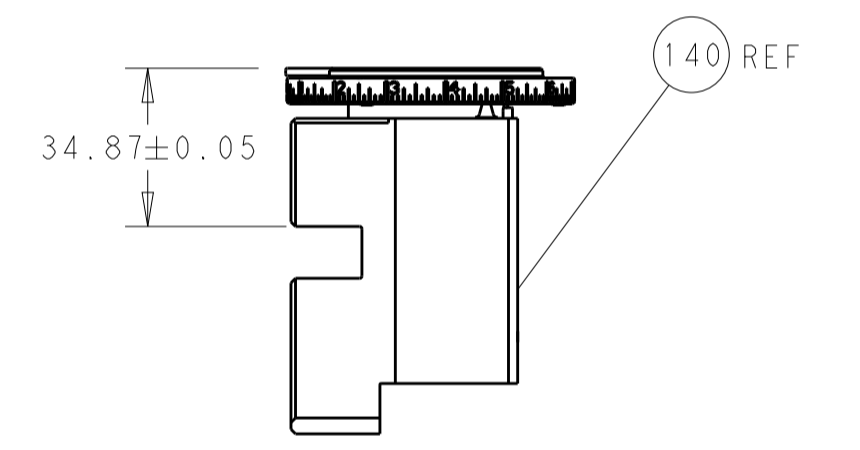

RAM SET-UP

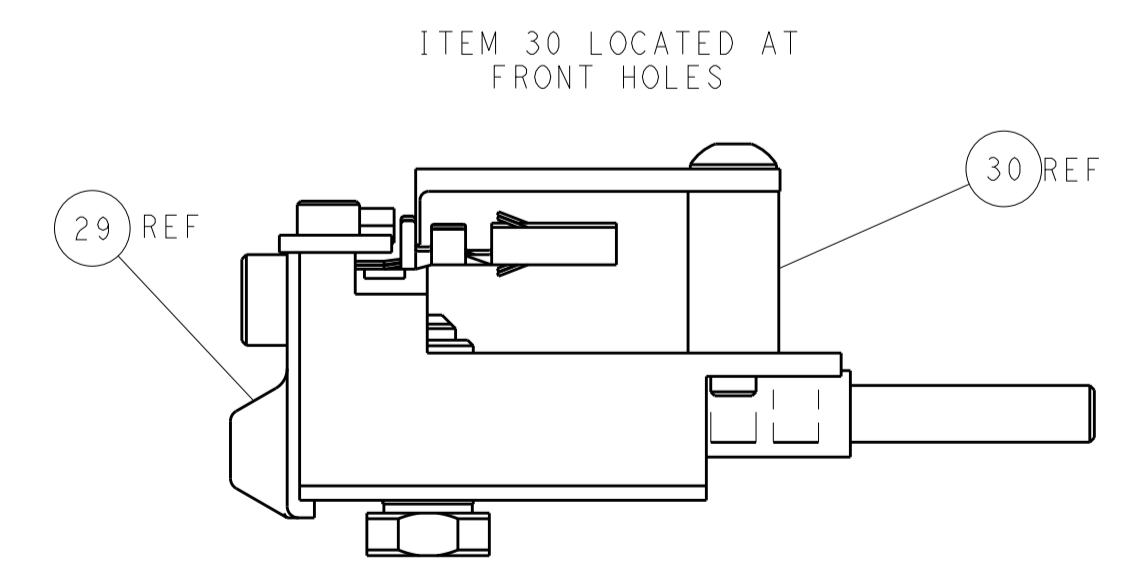

FEED TRACK POSITION  
GUIDE BY INSULATION BARREL

**PACIFIC VERSION**  
 Shown on sheets 3 of 4 & 4 of 4  
 (Atlantic version shown on sheets 1 of 4 & 2 of 4)

DIMENSIONS:		TOLERANCES UNLESS OTHERWISE SPECIFIED:		DWN L. ZHANG 17OCT2011		CHK L. ZHANG 17OCT2011		S. XI 17OCT2011		NAME		APVD	
mm	0 PLC	±		PRODUCT SPEC		APPLICATION SPEC		SIZE		CAGE CODE		DRAWING NO	
	1 PLC	±		RESTRICTED TO		SCALE		SHEET		OF		REV	
	2 PLC	±		Customer Accessible Production Drawing		1:2		4		4		D	
	3 PLC	±											
	4 PLC	±											
	ANGLES	±											
MATERIAL	FINISH												



Ocean Side Feed  
Applicator