

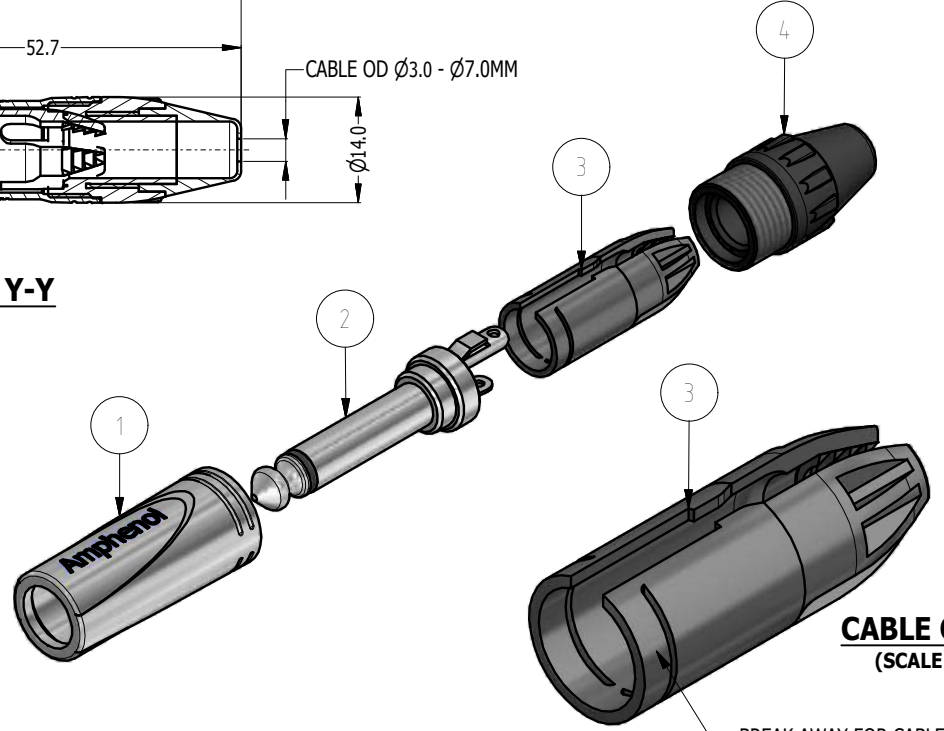

REVISION HISTORY			
REV	DESCRIPTION	DATE	CHG No
1	FIRST ISSUE	30-05-17	----
2	UPDATED CABLE CLAMP	24-01-18	9476

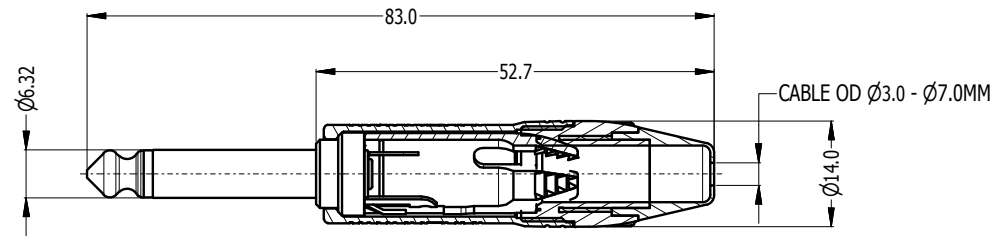
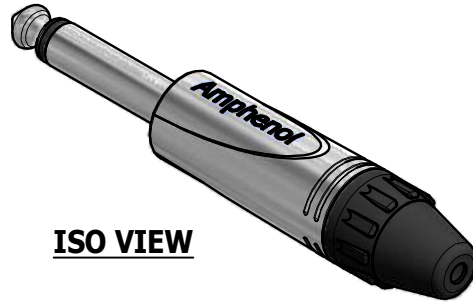
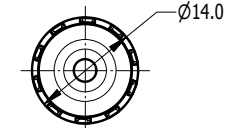
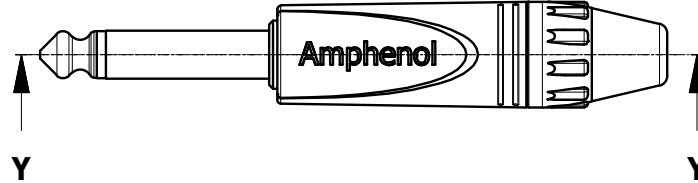
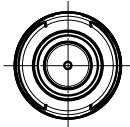

**CABLE CLAMP**  
(SCALE 2 : 1)

BREAK AWAY FOR CABLE  
OD RANGE FROM 5-7mm

CATALOGUE PN	SHELL FINISH	CONTACT FINISH	BACKSHELL FINISH
QM2P	NICKEL	NICKEL SLEEVE AND TIP	MATT BLACK
QM2PB-AU	MATT BLACK	GOLD SLEEVE AND TIP	MATT BLACK

ITEM	PART NUMBER	DESCRIPTION	QTY	DO NOT SCALE
4	50440055-300	THERMOPLASTIC BACKSHELL - BLACK	1	
3	50260024-500	THERMOPLASTIC CABLE CLAMP - BLACK	1	
2	50310064-100/300	MONO INSERT ASSEMBLY - GOLD/NICKEL	1	
1	53480189-300/400	DIECAST SHELL - NICKEL/MATT BLACK	1	

Parts List

UNLESS OTHERWISE SPECIFIED  
TOLERANCE TO BE

LINEAR	ANGULAR
X ±0.5	X' ±1
X.X ±0.1	X.X' ±30'
X.XX ±0.05	X.XX" ±15'

BREAK ALL SHARP EDGES  
AND REMOVE ALL BURRS

FINISH: **SEE TABLE**

DIMENSIONS IN MILLIMETRES

THIS DOCUMENT IS THE PROPERTY OF AMPHENOL AUSTRALIA PTY. LTD.  
NO PART THEREOF MAY BE REPRODUCED AND USED  
WITHOUT THE PRIOR WRITTEN CONSENT OF THE OWNER

MATERIAL: **REFER TO COMPONENT**

DRN: MH DATE: 30-05-17  
CKD: MH DATE: 24-01-18  
APP'D: PM DATE: 24-01-18

SCALE: **1:1** SIZE: **A4**

**Amphenol** Amphenol Australia Pty.Ltd,  
22 Industry Blvd, Carrum Downs, VIC 3201

TITLE: **1/4" PHONE MONO PLUG CUSTOMER DRAWING**

PART No: **SEE TABLE**

DRAWING NO. **55011234-000-1** SHEET **2/2**

CAD FILE 55011234000112