

## Features

- Low voltage operation
- Low current consumption
- Fast response time
- I<sup>2</sup>C communication protocol
- Reliable capacitive technology
- Relative humidity accuracy of ±2 % (Typical)

## Applications

Industrial:

- HVAC systems
- Process monitoring
- Climate monitoring, interior and exterior

\*\*Medical Devices (low/medium risk):

- Diagnostic equipment
- Analysis equipment

# BPS240 Series - 2 mm Humidity Sensor

### Absolute Maximum Ratings

Supply Voltage ( $V_{CC}$ )	-0.3 to 7.0 V
Input Voltage ( $V_I$ )	-0.3 to 7.0 V
CE	-0.3 to $V_{CC} + 0.3$ V
SCL/SDA	-0.3 to 7.0 V
Output Voltage ( $V_O$ )	-0.3 to $V_{CC} + 0.3$ V
Hi-level Output Current (IOH)	-5 mA
1 Terminal	-5 mA
All Terminals Total	-20 mA
Low-level Output Current (IOL)	5 mA
1 Terminal	5 mA
All Terminals Total	20 mA
Operating Temperature ( $T_a$ )	-40 °C to +105 °C
Storage Temperature ( $T_{stg}$ )	-50 °C to +125 °C

### Additional Information

Click these links for more information:



[PRODUCT](#) [TECHNICAL LIBRARY](#) [INVENTORY](#) [SAMPLES](#) [CONTACT](#)

### Recommended Operating Conditions

Power Supply Voltage ( $V_{CC}$ )	1.62 to 5.5 VDC
Capacitance between $V_{CC}$ and $V_{SS}$ ( $C_p$ )	0.1 $\mu$ F typical
Pull Up Resistor Value on SDA <sup>1</sup> (R1)	5 k $\Omega$ typical
Pull Up Resistor Value on SCL <sup>1</sup> (R2)	5 k $\Omega$ typical

<sup>1</sup> Select the resistance value to meet AC characteristics.

### Electrical Characteristics

Humidity Detection	
Measurement Range	0 to 100 % RH
Resolution (10-bit)	0.1 % RH typical
Humidity Accuracy - Typical (see Humidity Sensor Accuracy Graph for Maximum Rating)	
@ 25 °C (20 to 80 % RH)	±2 % RH
@ 5 °C to 45 °C (0 to 100 % RH)	±4 % RH
Hysteresis @ 5 °C to 45 °C (0 to 100 % RH)	±1 % RH typical
Response Time	
Reach ( $\tau$ 63 % @ 25 °C, wind velocity @ 1.0 m/s)	1 second

Unless otherwise specified:  $V_{CC} = 1.62$  to  $5.5$  V,  $V_{SS} = 0$  V,  $T_a = -30$  °C to  $100$  °C

Temperature Detection	
Measurement Range	-30 °C to +100 °C
Resolution (11 bit)	0.1 °C
-30 °C to +100 °C	0.1 °C
Temperature Accuracy	
@ 5 °C to 60 °C	±0.3 °C
@ -20 °C to 85 °C	±1.0 °C
Reproducibility @ -30 °C to 100 °C	±0.1 °C
Response Time	
Reach ( $\tau$ 63 % (dependent on surrounding heat conduction NOTE 1))	30 seconds

Unless otherwise specified:  $V_{CC} = 1.62$  to  $5.5$  V,  $V_{SS} = 0$  V,  $T_a = -30$  °C to  $100$  °C

NOTE 1 Extended exposure to >90 % RH causes a shift of up to 3 % RH which is reversible after a period of 14 days.

### Current Consumption

Sleep Current (CE=0, Sleep Mode)	10 nA typical, 400 nA maximum
Average Operating Current	4.8 $\mu$ A typical, 10 $\mu$ A maximum

Unless otherwise specified:  $V_{CC} = 1.62$  to  $5.5$  V,  $V_{SS} = 0$  V,  $T_a = 0$  °C to  $60$  °C

\* RoHS3 Directive 2015/863 Amendments of Annex II on March 31, 2015

\*\* Bourns® products have not been designed for and are not intended for use in "lifesaving," "life-critical" or "life-sustaining" applications nor any other applications where failure or malfunction of the Bourns® product may result in personal injury or death. See Legal Disclaimer Notice on the last page of this document.

Specifications are subject to change without notice.

Users should verify actual device performance in their specific applications.

The products described herein and this document are subject to specific legal disclaimers as set forth on the last page of this document, and at [www.bourns.com/docs/legal/disclaimer.pdf](http://www.bourns.com/docs/legal/disclaimer.pdf).



**WARNING Cancer and Reproductive Harm**  
[www.P65Warnings.ca.gov](http://www.P65Warnings.ca.gov)

# BPS240 Series - 2 mm Humidity Sensor



## Input/Output Terminal Characteristics

High Level Input Voltage 1 (VIH1) [Target Terminal: SCL, SDA]	.....0.7 V <sub>CC</sub> minimum, V <sub>CC</sub> maximum
High Level Input Voltage 2 (VIH2) [Target Terminal: CE]	.....0.8 V <sub>CC</sub> minimum, V <sub>CC</sub> maximum
Low Level Input Voltage 1 (VIL1) [Target Terminal: SCL, SDA]	.....V <sub>SS</sub> minimum, 0.3 V <sub>CC</sub> maximum
Low Level Input Voltage 2 (VIL2) [Target Terminal: CE]	.....V <sub>SS</sub> minimum, 0.2 V <sub>CC</sub> maximum
Low Level Output Current (IOL) [VOL = 0.1 V <sub>CC</sub> , Target Terminal: SCL, SDA]	.....0.5 mA minimum
Terminal Leak Current 1 (IL1) [Terminal voltage = V <sub>CC</sub> , Target Terminal: SCL, SDA]	.....± 1 μA
Terminal Leak Current 2 (IL2) [Terminal voltage = 0 V, Target Terminal: SCL, SDA, CE]	.....± 1 μA
Input Pull-Down Resistance (RPD) [Terminal voltage = V <sub>CC</sub> , Target Terminal: CE]	.....60 kΩ minimum, 150 kΩ typical, 450 kΩ maximum

Unless otherwise specified: V<sub>CC</sub> = 1.62 to 5.5 V, V<sub>SS</sub> = 0 V, T<sub>a</sub> = -30 °C to 100 °C

## Product Characteristics

Moisture Sensitivity Level	.....1
ESD Classification (HBM)	.....1 kV
Marking	..... <b>B</b> , Date Code
Standard Packaging	.....2,000 pcs. per 7-inch reel
Weight	.....10.45 milligrams

## Product Dimensions

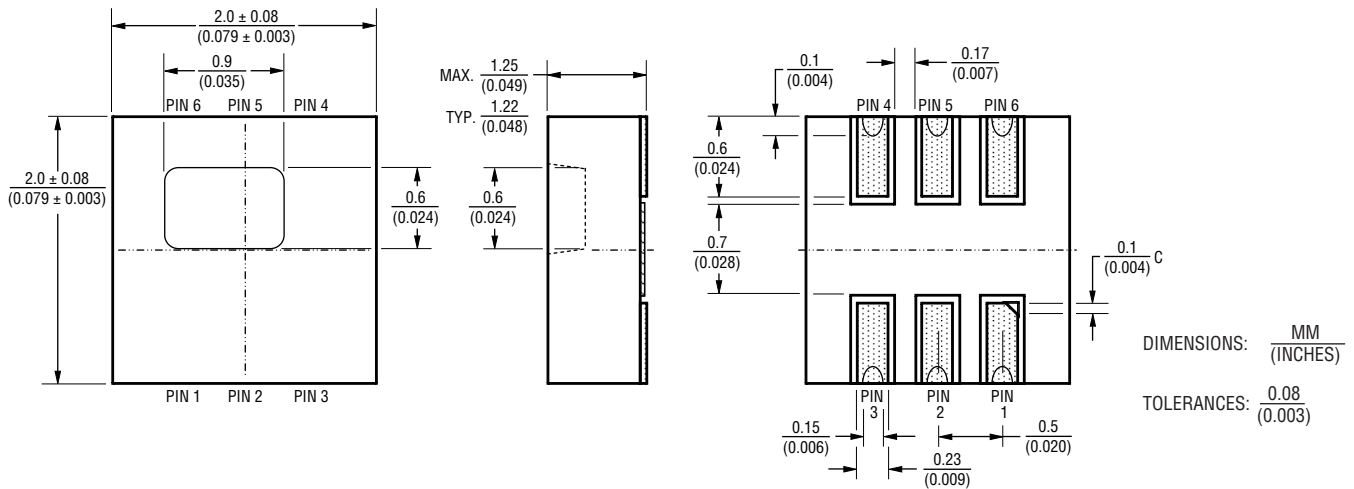

## Recommended PCB Layout

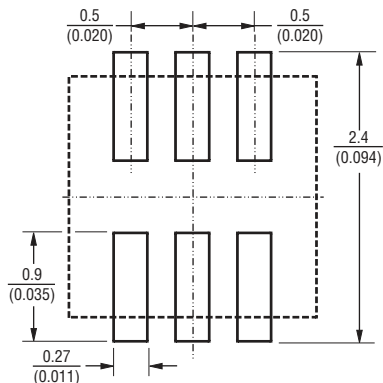

## Terminal Assignment

No.	Terminal Name	Function
1	CE	Chip enable terminal
2	V <sub>SS</sub>	Power supply terminal (-)
3	V <sub>CC</sub>	Power supply terminal (+)
4	V <sub>DD</sub>	Internal constant voltage output terminal
5	SDA	I <sup>2</sup> C serial data
6	SCL	I <sup>2</sup> C serial clock

Specifications are subject to change without notice.

Users should verify actual device performance in their specific applications.

The products described herein and this document are subject to specific legal disclaimers as set forth on the last page of this document, and at [www.bourns.com/docs/legal/disclaimer.pdf](http://www.bourns.com/docs/legal/disclaimer.pdf).

# BPS240 Series - 2 mm Humidity Sensor

**BOURNS®**

## Basic Circuit Schematic

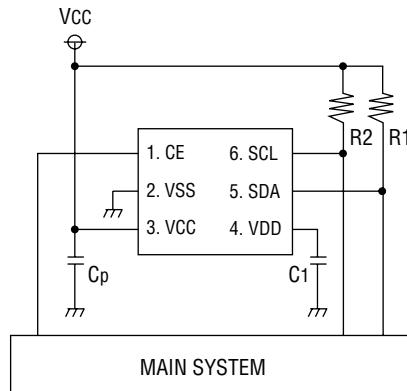

C<sub>p</sub> ..... 0.1  $\mu$ F  
 C1 ..... 0.47  $\mu$ F  
 R1-R2 ..... 5k  $\Omega$

NOTE: R1 and R2 are reference values. Resistor values should be selected to meet the AC characteristics.

## Operation Mode

Operation Mode	Terminal Setup	Operation State of Each Functional Block						
	CE	V <sub>pp</sub>	Power Supply	Oscillation	Temp. Detection	Capacitance Detection	OTP Memory	I <sup>2</sup> C-Bus
Sleep *1	0	NC	Stop	Stop	Stop	Stop	Stop	Stop
Standby	1	NC	Operation	Operation	Stop	Stop	Read-out Possible	Operation

\*1 In case of power control mode, there is no sleep operation.  
 I<sup>2</sup>C slave address (SADR) is defined as "111 1111" (7Fh).

## Control Register Map

Address	Bit	Bit Name	Function	Value	Read-Out	Write-In	R/W	Init.
00h	D7-1	-	Reserved	-			R	0
	D0	RESET	Reset	0	Normal Operation	None	R/W	0
1				-	Reset Action			
01h	D7-6	MANMODE	Manual Detection Mode	00	Normal Operation Mode		R/W	0
	D5-3	HAVE[2:0]	Humidity Detection Value Avg. Mode	000	No Averaging Process			
				001	2 Times Average Mode			
				01x	4 Times Average Mode			
				1xx	8 Times Average Mode			
D2	TAVE	Temperature Detection Value Avg. Mode	0	8 Times Average Mode		R/W	0	
1	16 Times Average Mode							

Specifications are subject to change without notice.

Users should verify actual device performance in their specific applications.

The products described herein and this document are subject to specific legal disclaimers as set forth on the last page of this document, and at [www.bourns.com/docs/legal/disclaimer.pdf](http://www.bourns.com/docs/legal/disclaimer.pdf).

**Control Register Map (Continued)**

Address	Bit	Bit Name	Function	Value	Read-Out	Write-In	R/W	Init.
01h	D1	-	Reserved	-			R	0
	D0	MAN	Manual Detection Mode	0	Standby State	Detection Operation Stop	R/W	0
				1	Under Detection Operation	Detection Operation Start		
03h	D7-1	-	Reserved	-			R	0
	D0	ERR	Manual Detection Error Flag	0	No Error	Nothing is Done	R/W	0
1				Error Occurred	Error Flag Reset			
04h	D7-0	HC[7:0]	Humidity Detection Result <i>(After Correction Operation)</i>	000h-3FFh			R	X
05h	D7-2	-	Reserved	-			R	0
	D1-0	HC[9:8]	Humidity Detection Result <i>(After Correction Operation)</i>				R	X
06h	D7-0	TC[7:0]	Temperature Detection Result <i>(After Correction Operation)</i>	000h-7FFh			R	X
07h	D7-3	-	Reserved	-			R	0
	D2-0	TC[10:8]	Temperature Detection Result <i>(After Correction Operation)</i>				R	X
0Ah	D7-0	K[7:0]	Capacity Detection Result <i>(Before Correction Operation)</i>	000h-FFFFh			R	0

Specifications are subject to change without notice.

Users should verify actual device performance in their specific applications.

The products described herein and this document are subject to specific legal disclaimers as set forth on the last page of this document, and at [www.bourns.com/docs/legal/disclaimer.pdf](http://www.bourns.com/docs/legal/disclaimer.pdf).

**Control Register Map (Continued)**

Address	Bit	Bit Name	Function	Value	Read-Out	Write-In	R/W	Init.
0Bh	D7-0	K[15:8]	Capacity Detection Result <i>(Before Correction Operation)</i>				R	0
2Ch	D7-5	-	Reserved	-	-		R	0
	D4	SCR_ON_R	Standard Capacity Connection Control	0	Outside Capacity Cutting	R/W	0	
				1	Outside Capacity Connection			
D3-0	SCI_ON_R[3:0]	Internal Capacity Connection Control	0h~Fh x 0.6 pF Example: At the time of 8 hours, access to internal capacity of 4.8 pF			R/W	X	
03h	D7-1	-	Reserved	-			R	0
	D0	ERR	Manual Detection Error Flag	0	No Error	Nothing is Done	R/W	0
1				Error Occurred	Error Flag Reset			

**Transfer Function Formula**

**Humidity**

$$RH = \frac{100}{2^{10}} \times RH_{IC} \quad (0 \sim 100 \% RH)$$

RH<sub>IC</sub> : IC Humidity Output Data (10 bit)

Refer to Register Map:

RH<sub>IC</sub> = Data of the addresses 04H and 05H (000h ~ 3FFh)  
It changes into a decimal and is operation.

**Temperature**

$$T = [T_{IC} - (2^{10} - \frac{25}{0.1})] \times 0.1 \quad (-30 \sim 100 \text{ }^\circ\text{C})$$

T<sub>IC</sub> : IC Temperature Output Data (11 bit)

Refer to Register Map:

T<sub>IC</sub> = Data of the addresses 06H and 07H (000h ~ 7FFh)  
It changes into a decimal and is operation.

# BPS240 Series - 2 mm Humidity Sensor



## Capacitance/Temperature Detection Sequence

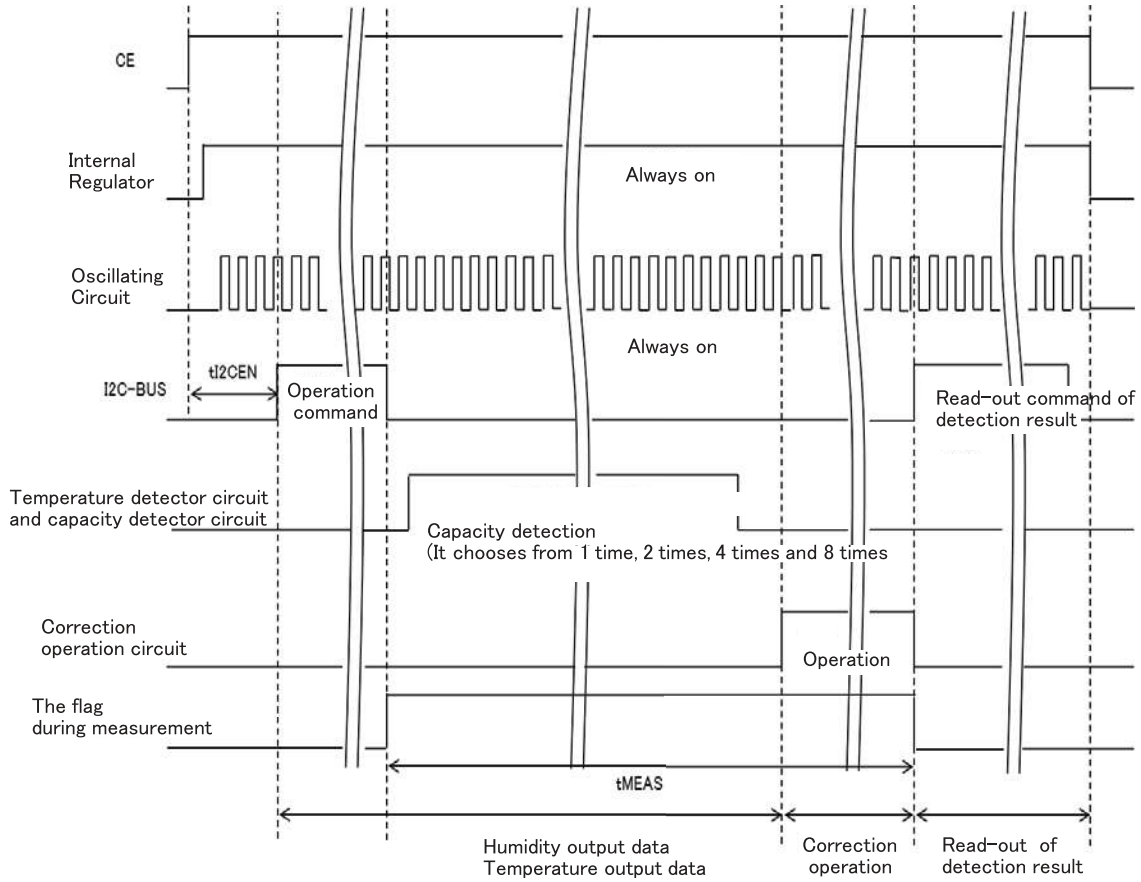

## How To Order

**BPS240 - D 2P0 - S 10 E**

Model Series	_____	_____	_____	_____	_____
Humidity-Temperature Sensor	_____	_____	_____	_____	_____
Output Type	_____	_____	_____	_____	_____
D = Digital	_____	_____	_____	_____	_____
Accuracy (% RH)	_____	_____	_____	_____	_____
2P0 = ±2.0	_____	_____	_____	_____	_____
Moisture Sensitivity	_____	_____	_____	_____	_____
S = Standard	_____	_____	_____	_____	_____
Resolution	_____	_____	_____	_____	_____
10 = 10-bit	_____	_____	_____	_____	_____
Packaging Designator	_____	_____	_____	_____	_____
E = 2,000 pcs. per 7-inch Reel	_____	_____	_____	_____	_____

Specifications are subject to change without notice.  
 Users should verify actual device performance in their specific applications.  
 The products described herein and this document are subject to specific legal disclaimers as set forth on the last page of this document, and at [www.bourns.com/docs/legal/disclaimer.pdf](http://www.bourns.com/docs/legal/disclaimer.pdf).

## Output Type Waveform and Data Read/Write Procedure

### I<sup>2</sup>C-BUS Data Read-out Procedure

- ① I<sup>2</sup>C master device releases START condition.
- ② I<sup>2</sup>C master device transmits slave address and WRITE mode selection.
- ③ I<sup>2</sup>C master device transmits register address of this IC.
- ④ I<sup>2</sup>C master device releases repeated START condition. (Release method is same as START condition.)
- ⑤ I<sup>2</sup>C master device again transmits slave address and READ mode selection. (Read mode can be selected by transmitting "1" in 8th bit.)
- ⑥ I<sup>2</sup>C master device reads-out data from register address designated at ③.  
It is possible to read-out data while register address increments one, by reading-out multiple data continuously. However, during continuous read-out, please return ACK to this IC as a reply of master.
- ⑦ After the completion of all read-out, I<sup>2</sup>C master device releases STOP condition.

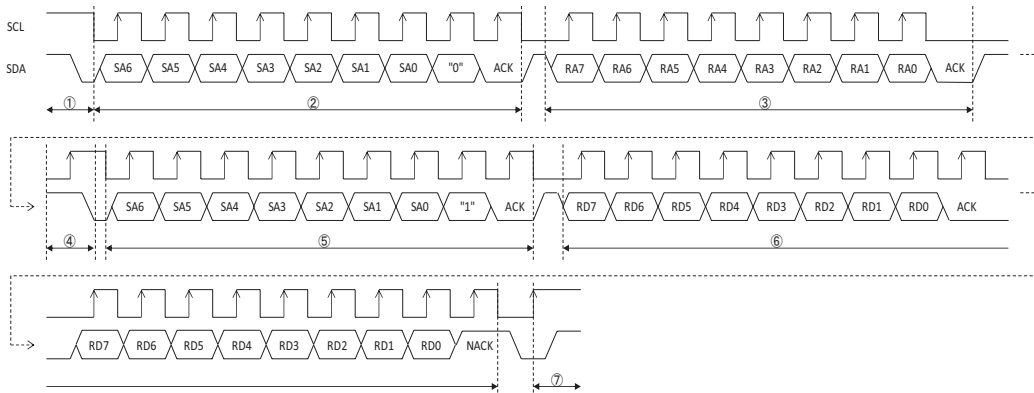

~ Continued ~

## Output Type Waveform and Data Read/Write Procedure (Continued)

### I<sup>2</sup>C-BUS Data Write-in Procedure

- ① I<sup>2</sup>C master device releases START condition. (Start condition can be released by changing SDA from “H” to “L” while SCL is in “H” state.)
- ② I<sup>2</sup>C master device transmits slave address and WRITE mode selection. (Write mode can be selected by transmitting “0” in 8th bit while 1~7th bits are slave address.)
- ③ I<sup>2</sup>C master device transmits register address of this IC.
- ④ I<sup>2</sup>C master device transmits write-in data.
- ⑤ It is possible to write-in data while register address increments one, by transmitting multiple write-in data continuously.

After the completion of transmitting all write-in data, I<sup>2</sup>C master device releases stop condition. (Stop condition can be released by changing SDA from “L” to “H” while SCL is in “H” state.)

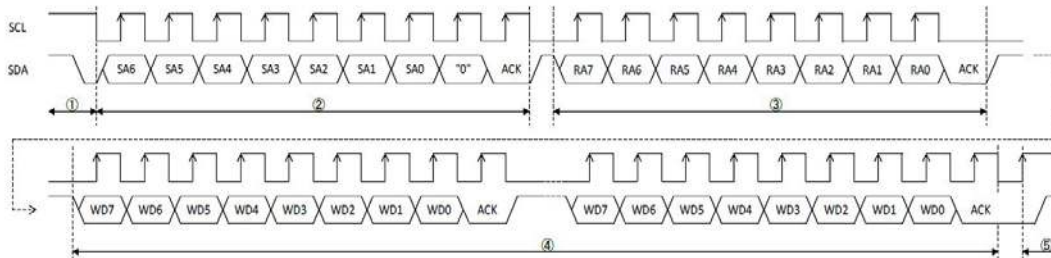

### Solder Profile

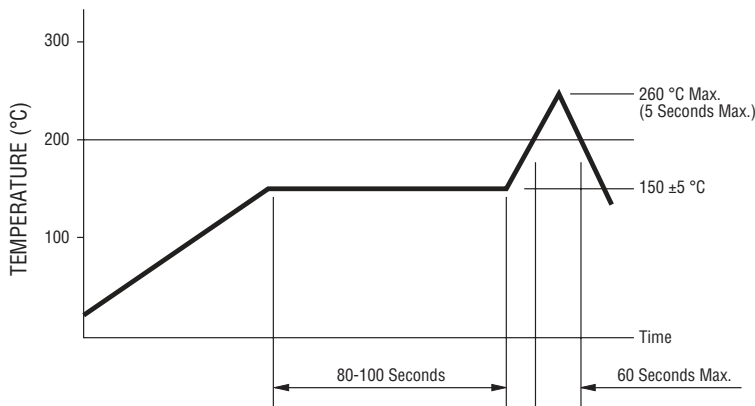

Processing Method: Reflow soldering with infrared heat or forced air convection (only once).

#### Notes:

1. No clean solder paste is recommended.
2. Aqueous wash is not recommended.
3. Use of water soluble soldering flux should be avoided due to possible corrosion.
4. Multiple passes through the soldering process is not recommended.
5. Other SMD processes and profiles should be verified by the customer.



# BPS240 Series - 2 mm Humidity Sensor



## Humidity Sensor Accuracy

Relative Humidity (% RH)	Maximum	Typical
0	5	4
10	4	3
20	3	2
30	3	2
40	3	2
50	3	2
60	3	2
70	3	2
80	3	2
90	4	3
100	5	4

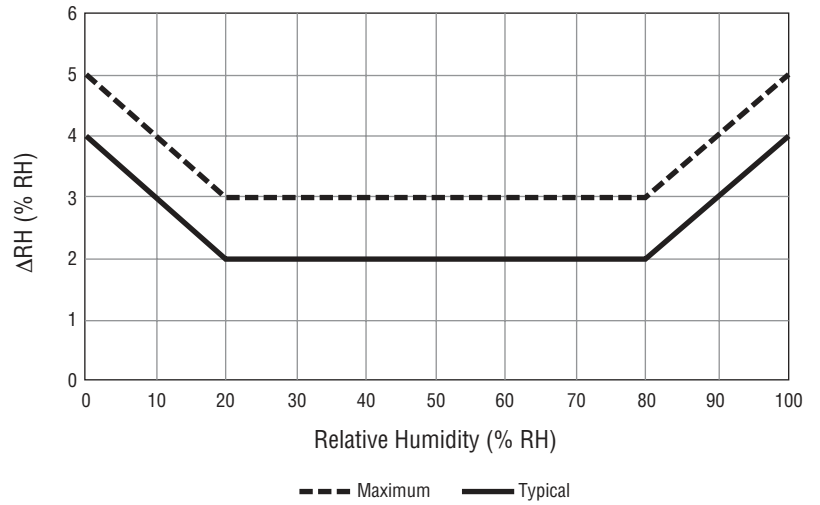

Specifications are subject to change without notice.

Users should verify actual device performance in their specific applications.

The products described herein and this document are subject to specific legal disclaimers as set forth on the last page of this document, and at [www.bourns.com/docs/legal/disclaimer.pdf](http://www.bourns.com/docs/legal/disclaimer.pdf).

# BPS240 Series - 2 mm Humidity Sensor

**BOURNS®**

## Packaging Specification

2000 pieces per 7-inch reel.  
Meets specifications of  
EIA-481-1 or EIA-481-2.

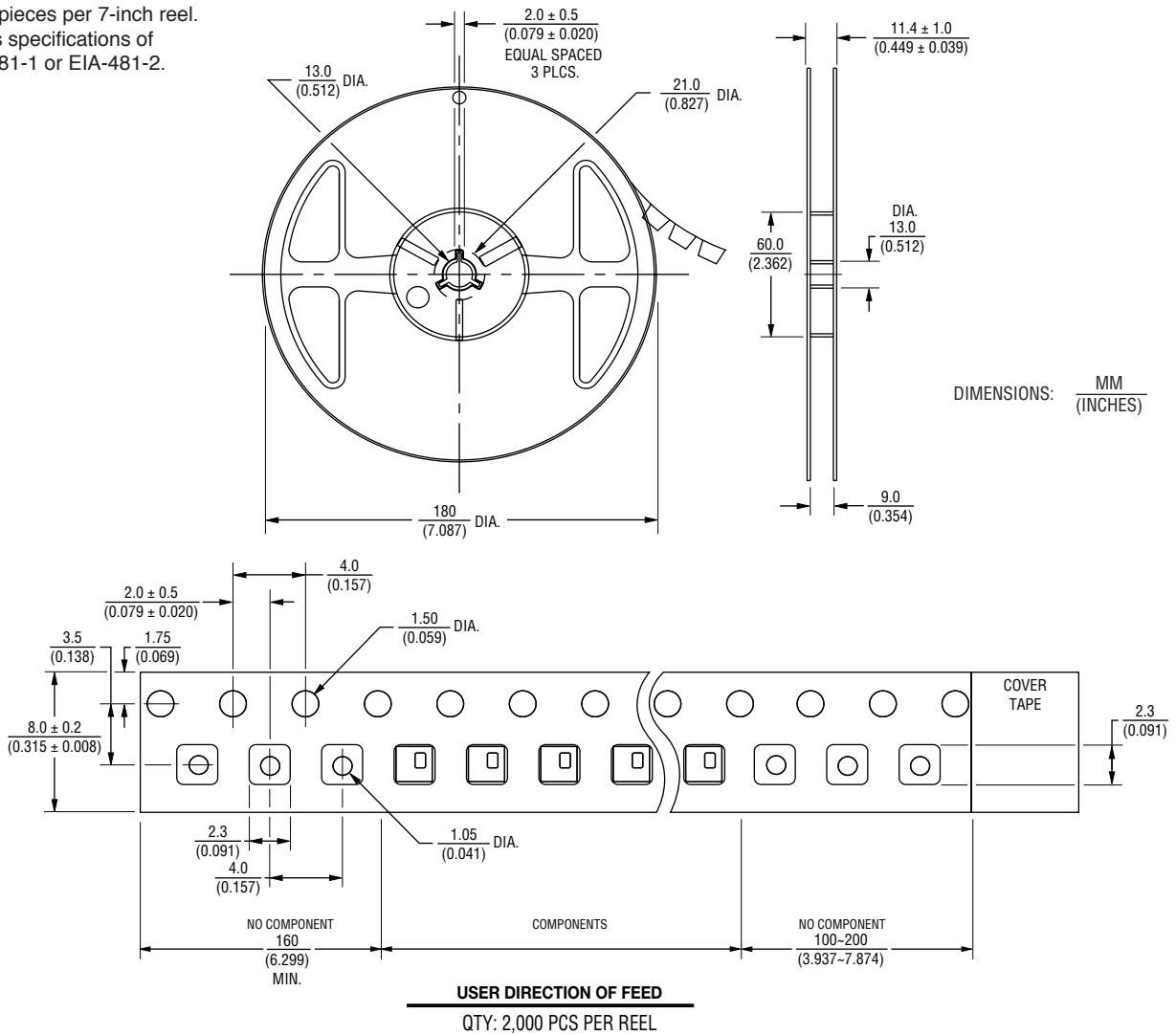

**BOURNS®**

Asia-Pacific: Tel: +886-2 2562-4117 • Email: asiacus@bourns.com

EMEA: Tel: +36 88 885 877 • Email: eurocus@bourns.com

The Americas: Tel: +1-951 781-5500 • Email: americus@bourns.com

[www.bourns.com](http://www.bourns.com)

REV. 12/21

Specifications are subject to change without notice.

Users should verify actual device performance in their specific applications.

The products described herein and this document are subject to specific legal disclaimers as set forth on the last page of this document, and at [www.bourns.com/docs/legal/disclaimer.pdf](http://www.bourns.com/docs/legal/disclaimer.pdf).

This legal disclaimer applies to purchasers and users of Bourns® products manufactured by or on behalf of Bourns, Inc. and its affiliates (collectively, "Bourns").

Unless otherwise expressly indicated in writing, Bourns® products and data sheets relating thereto are subject to change without notice. Users should check for and obtain the latest relevant information and verify that such information is current and complete before placing orders for Bourns® products.

The characteristics and parameters of a Bourns® product set forth in its data sheet are based on laboratory conditions, and statements regarding the suitability of products for certain types of applications are based on Bourns' knowledge of typical requirements in generic applications. The characteristics and parameters of a Bourns® product in a user application may vary from the data sheet characteristics and parameters due to (i) the combination of the Bourns® product with other components in the user's application, or (ii) the environment of the user application itself. The characteristics and parameters of a Bourns® product also can and do vary in different applications and actual performance may vary over time. Users should always verify the actual performance of the Bourns® product in their specific devices and applications, and make their own independent judgments regarding the amount of additional test margin to design into their device or application to compensate for differences between laboratory and real world conditions.

Unless Bourns has explicitly designated an individual Bourns® product as meeting the requirements of a particular industry standard (e.g., ISO/TS 16949) or a particular qualification (e.g., UL listed or recognized), Bourns is not responsible for any failure of an individual Bourns® product to meet the requirements of such industry standard or particular qualification. Users of Bourns® products are responsible for ensuring compliance with safety-related requirements and standards applicable to their devices or applications.

Bourns® products are not recommended, authorized or intended for use in nuclear, lifesaving, life-critical or life-sustaining applications, nor in any other applications where failure or malfunction may result in personal injury, death, or severe property or environmental damage. Unless expressly and specifically approved in writing by two authorized Bourns representatives on a case-by-case basis, use of any Bourns® products in such unauthorized applications might not be safe and thus is at the user's sole risk. Life-critical applications include devices identified by the U.S. Food and Drug Administration as Class III devices and generally equivalent classifications outside of the United States.

Bourns expressly identifies those Bourns® standard products that are suitable for use in automotive applications on such products' data sheets in the section entitled "Applications." Unless expressly and specifically approved in writing by two authorized Bourns representatives on a case-by-case basis, use of any other Bourns® standard products in an automotive application might not be safe and thus is not recommended, authorized or intended and is at the user's sole risk. If Bourns expressly identifies a sub-category of automotive application in the data sheet for its standard products (such as infotainment or lighting), such identification means that Bourns has reviewed its standard product and has determined that if such Bourns® standard product is considered for potential use in automotive applications, it should only be used in such sub-category of automotive applications. Any reference to Bourns® standard product in the data sheet as compliant with the AEC-Q standard or "automotive grade" does not by itself mean that Bourns has approved such product for use in an automotive application.

Bourns® standard products are not tested to comply with United States Federal Aviation Administration standards generally or any other generally equivalent governmental organization standard applicable to products designed or manufactured for use in aircraft or space applications. Bourns expressly identifies Bourns® standard products that are suitable for use in aircraft or space applications on such products' data sheets in the section entitled "Applications." Unless expressly and specifically approved in writing by two authorized Bourns representatives on a case-by-case basis, use of any other Bourns® standard product in an aircraft or space application might not be safe and thus is not recommended, authorized or intended and is at the user's sole risk.

The use and level of testing applicable to Bourns® custom products shall be negotiated on a case-by-case basis by Bourns and the user for which such Bourns® custom products are specially designed. Absent a written agreement between Bourns and the user regarding the use and level of such testing, the above provisions applicable to Bourns® standard products shall also apply to such Bourns® custom products.

Users shall not sell, transfer, export or re-export any Bourns® products or technology for use in activities which involve the design, development, production, use or stockpiling of nuclear, chemical or biological weapons or missiles, nor shall they use Bourns® products or technology in any facility which engages in activities relating to such devices. The foregoing restrictions apply to all uses and applications that violate national or international prohibitions, including embargos or international regulations. Further, Bourns® products and Bourns technology and technical data may not under any circumstance be exported or re-exported to countries subject to international sanctions or embargoes. Bourns® products may not, without prior authorization from Bourns and/or the U.S. Government, be resold, transferred, or re-exported to any party not eligible to receive U.S. commodities, software, and technical data.

To the maximum extent permitted by applicable law, Bourns disclaims (i) any and all liability for special, punitive, consequential, incidental or indirect damages or lost revenues or lost profits, and (ii) any and all implied warranties, including implied warranties of fitness for particular purpose, non-infringement and merchantability.

*For your convenience, copies of this Legal Disclaimer Notice with German, Spanish, Japanese, Traditional Chinese and Simplified Chinese bilingual versions are available at:*

*Web Page:* <http://www.bourns.com/legal/disclaimers-terms-and-policies>

*PDF:* <http://www.bourns.com/docs/Legal/disclaimer.pdf>