

THIS DRAWING CONTAINS INFORMATION PROPRIETARY TO RF INDUSTRIES,  
 ANY UNAUTHORIZED USE OF THIS DRAWING IS EXPRESSLY PROHIBITED  
 WITHOUT WRITTEN PERMISSION FROM RF INDUSTRIES.  
 ANY VIOLATION IS PUNISHABLE UNDER U.S. COPYRIGHT LAWS.

ALL DIMENSIONS ARE REFERENCE ONLY

PART NO.

**RQA-5010-X**

REV	DESCRIPTION	DWN	DATE	APPROVED
-	ENGINEERING RELEASE	CZS	2/27/04	JDMc
A	CHANGE FERRULE LENGTH FROM .394"	JDM	4/5/06	JDMc
B	ADDED TOOL NOTE.	JDM	4/28/06	JDMc

NOTE: END CAP TO BE PRESSED INTO THE BODY CAVITY AFTER ATTACHING CABLE.

**\*\*USE QMA TOOL TO PRESS THE END CAP (ITEM 6)  
 INTO THE BODY TO AVOID DAMAGE TO THE SPRING**

RFI PART NUMBER "QMA-TOOL"

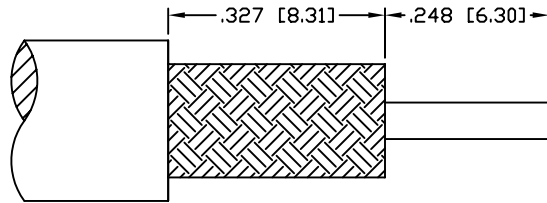

RECOMMENDED STRIPING DIMENSIONS

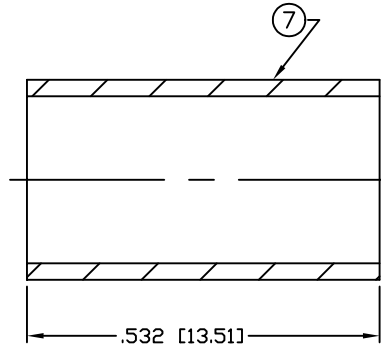

USE CRIMP DIE: .255"

CRIMP TOOL RFA-4005-20 / DIE RFA-4005-01

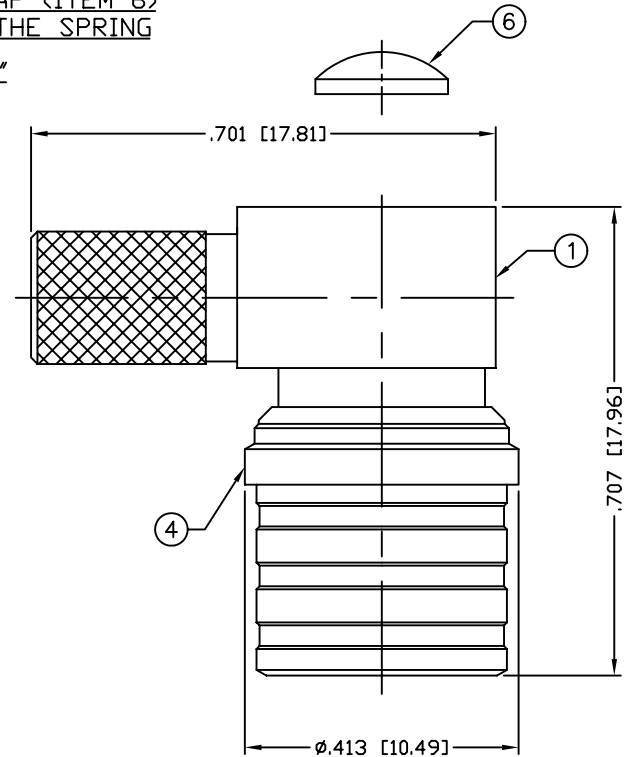

NOTE: ATTACH CABLE TO CONNECTOR BY  
 SOLDERING THE CABLE CENTER CONDUCTOR  
 TO THE PIN SLOT INSIDE THE CONNECTOR CAVITY.

**SPECIFICATIONS:**

IMPEDANCE: 50 Ohms  
 FREQUENCY RANGE: 0-6+ GHz  
 INSULATION RESISTANCE: 5k M Ohms min.  
 TEMPERATURE RANGE: -65°C TO 165°C  
 FOR RG-8/X, BELDEN 9258, MAXRAD MBX-100 &  
 MBX-1000, MICRO 8/U, REMEE 1600, SAXTON 8315 &  
 TIMES LMR-240 & LMR-240 ULTRAFLEX CABLE

1	BODY	1	BRASS	ALBALOY, 80μ"	008974	UNLESS OTHERWISE SPECIFIED:
2	INSULATOR	1	PTFE	---		
3	GROUND RING	1	WHITE BRONZE	ALBALOY, 80μ"		
4	SHELL	1	BRASS	ALBALOY, 80μ"		
5	PIN	1	BRASS	GOLD, 30μ"		
6	END CAP, PRESS	1	BRASS	ALBALOY, 80μ"		
7	FERRULE	1	COPPER	ALBALOY, 80μ"		
8						
9						
10					DRAWN	DIMENSIONS ARE IN INCHES AND [MILLIMETERS] UNLESS OTHERWISE NOTED TOLERANCES ARE: DECIMALS      DIAMETER
11				JDMc	4/28/06	
12				CHECKED		
13				ORJ DRAWN	6/4/04	
14				C. ZUNIGA		
#	DESCRIPTION	QTY	MATERIAL	FINISH	APPROVALS	DATE

**RFconnectors**  
 DIVISION OF RF INDUSTRIES, LTD.

7610 MIRAMAR RD  
 SAN DIEGO, CA 92126  
 (858) 549-6340  
 (858) 549-6345 FAX

**QMA PLUG, RIGHT ANGLE**

SIZE	CABLE GROUP	DWG NO.	REV
A	X	RQA-5010-X	B
SCALE: NTS	CAD FILE	OUTLINE	SHEET 1 OF 1