

REVISIONS					
P	LTR	DESCRIPTION	DATE	DMN	APVD
M1		REVISED PER ECO-16-004000	28SEP2016	NK	MZ

- 1 ZINC.
- 2 STAINLESS STEEL.
- 3 TO ASSEMBLE JACKSCREW REFER TO INSTRUCTION SHEET #1189.
- 4 HOLE CENTRALLY LOCATED WITHIN ± 0.07 [.003] OF THE 5.54 [.218] DIA AND THE 2.77/2.84 [.109/.112] DIA CENTER LINES.
- 5 CHROMATE CONVERSION, CLEAR.
- 7 NON-HEXAVALENT CHROMATE COATING ON JACKSCREW BODY.
- 8 SPECIAL PACKAGING - ONE UNASSEMBLED UNIT PER BAG

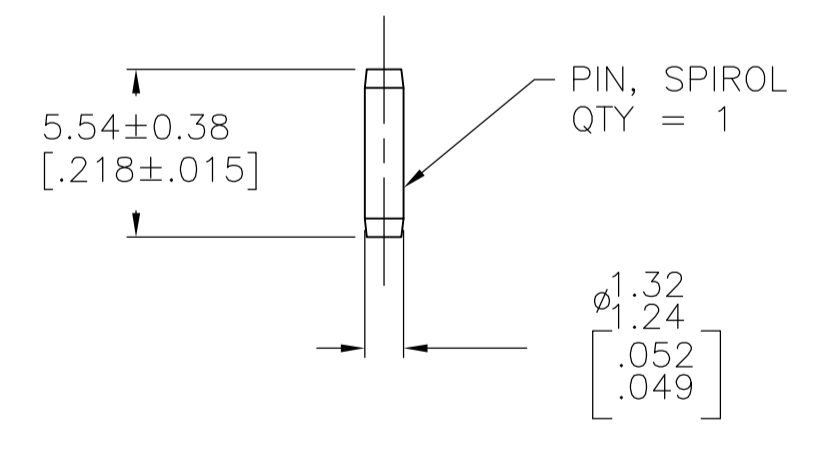
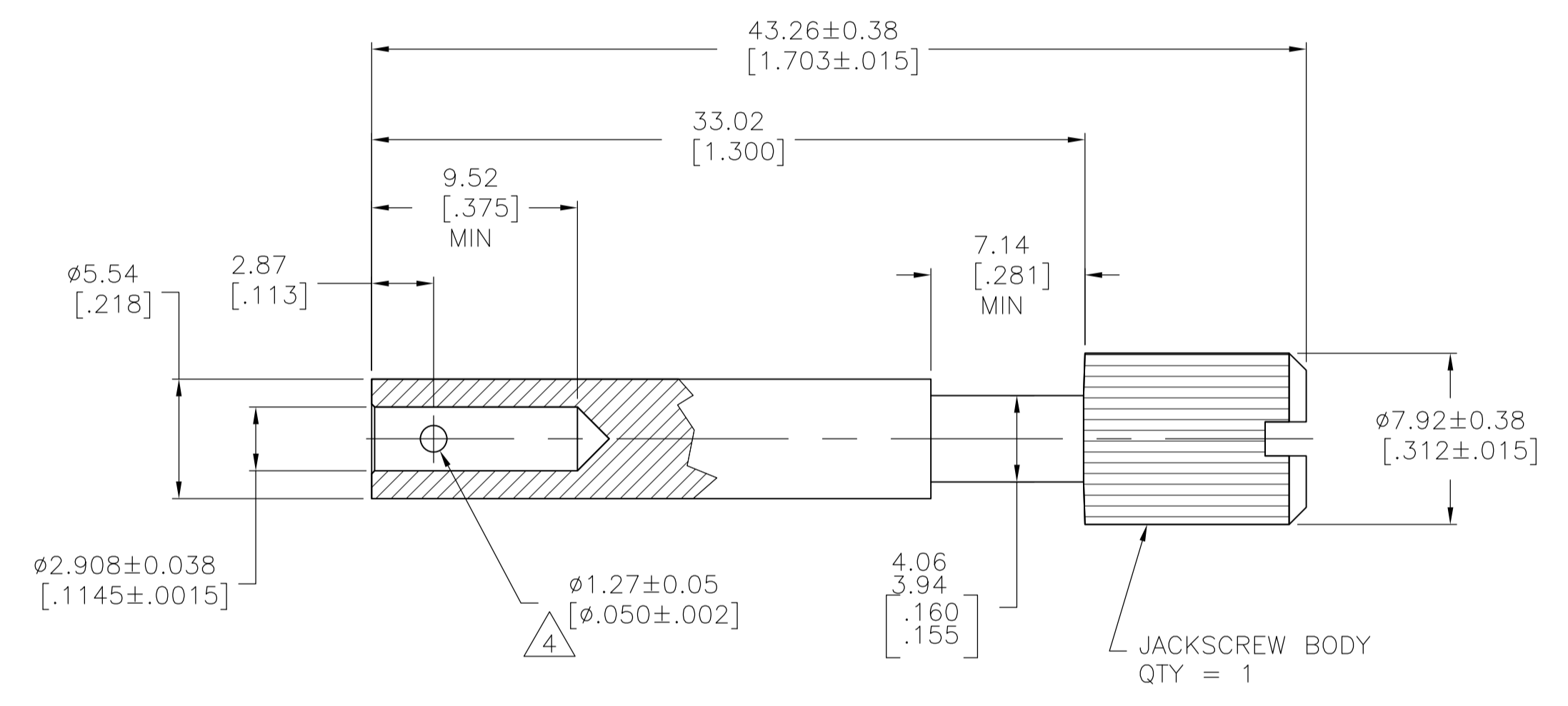
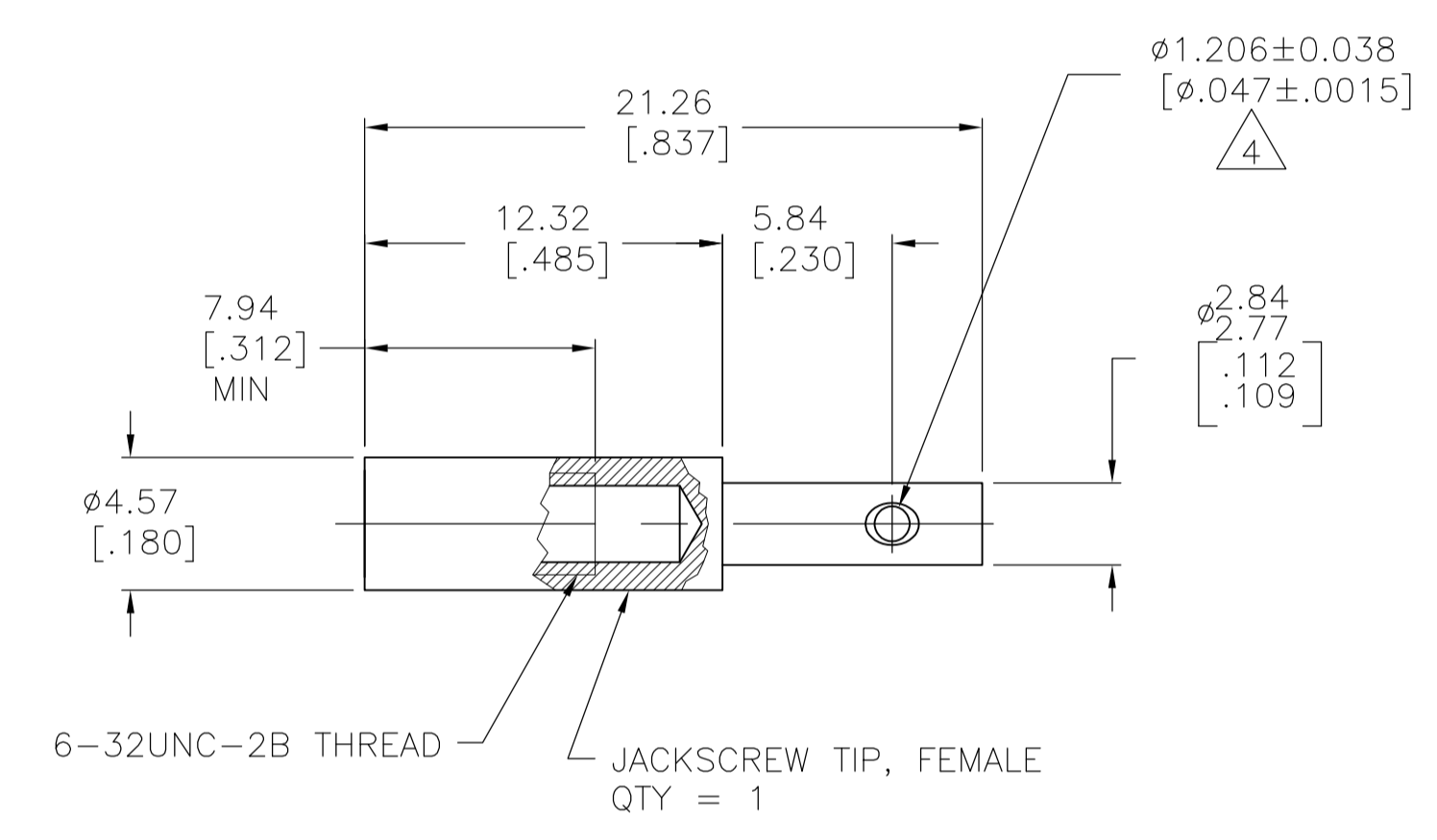

OBSOLETE	8	7	-201414-5-
	7	7	201414-4
	7	7	201414-1
NOTES			PART NUMBER

THIS DRAWING IS A CONTROLLED DOCUMENT.		DIN	K. FOLTZ	10/18/94
DIMENSIONS: mm [INCHES]		CHK	R. STONE	11/07/94
TOLERANCES UNLESS OTHERWISE SPECIFIED:		APVD		
0. PLC	± -	NAME		
1. PLC	± -	PRODUCT SPEC		
2. PLC	± 0.13 [.005]	APPLICATION SPEC		
3. PLC	± -	SIZE	CAGE CODE	DRAWING NO
4. PLC	± -	WEIGHT	A1	00779
ANGLES	± -	CUSTOMER DRAWING	SCALE	4:1
MATERIAL	JACKSCREW BODY: 1	FINISH	JACKSCREW BODY: 7	PIN: PASSIVATED
CUSTOMER DRAWING		SHEET 1 OF 1 REV M1		