

REVISIONS					
P	LTR	DESCRIPTION	DATE	DWN	APVD
	B	REVISED PER ECR-20-013339	20OCT2020	GK	MN

LABEL AND LINER DESIGN

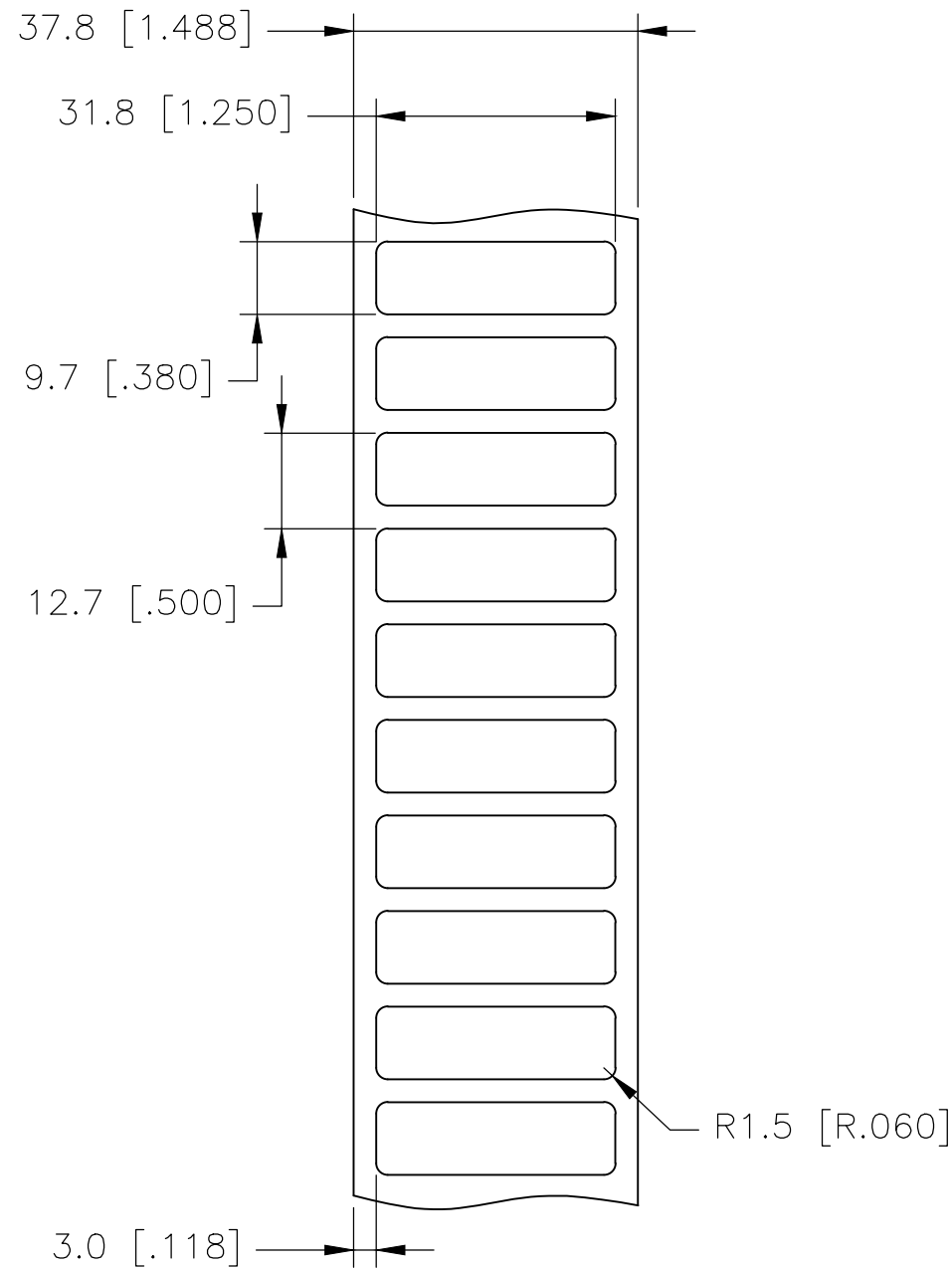

PRESENTATION

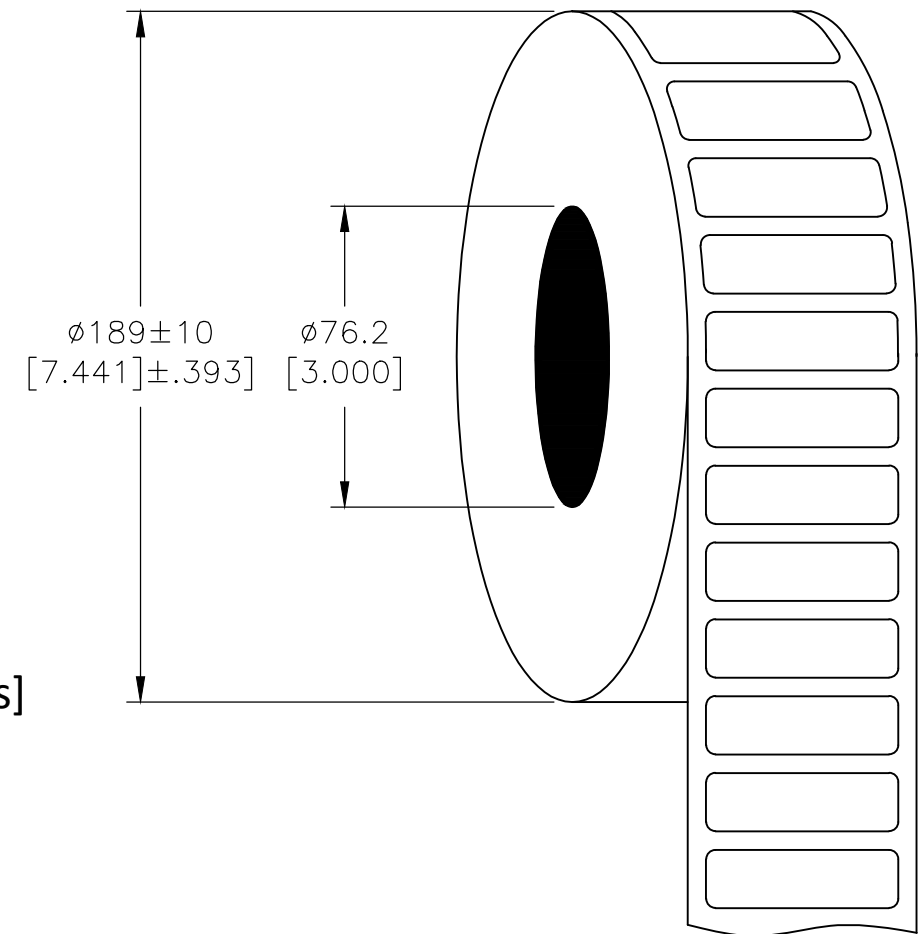

All dimensions in mm [Inches]

TE PN: F61662-000

**OUTSIDE WOUND
LABEL ACROSS: 1
PER ROLL QTY: 10000**

MATERIAL	HIGH TACK WHITE POLYESTER
ADHESIVE TYPE	PERMANENT ACRYLIC
LINER	GLASSINE PAPER

TOLERANCES mm [INCH]	
LABEL HEIGHT:	± 0.3 [.012]
LABEL WIDTH:	± 0.3 [.012]
WEB WIDTH:	± 0.8 [.031]
VERTICAL REPEAT:	± 0.8 [.031]*
HORIZONTAL REPEAT:	± 0.8 [.031]*
PRINT POSITIONING:	± 0.8 [.031]*
LEFT MARGIN:	± 0.4 [.016]
QUANTITY:	-0 % +2 %
*NON ACCUMULATING	

THIS DRAWING IS A CONTROLLED DOCUMENT.	
DIMENSIONS: mm [INCHES]	TOLERANCES UNLESS OTHERWISE SPECIFIED:
	0 PLC $\pm -$
	1 PLC $\pm -$
	2 PLC $\pm -$
	3 PLC $\pm -$
	4 PLC $\pm -$
MATERIAL SEE TABLE	FINISH -

DWN GOPALAKRISHNA HV 20OCT2020	TE Connectivity			
CHK MIKE NUTTALL 20OCT2020				
APVD MIKE NUTTALL 20OCT2020	NAME HW - HIGH TACK WHITE POLYESTER LABELS			
PRODUCT SPEC TTDS-076	SIZE A3	CAGE CODE C2290	DRAWING NO G-HW-318097-10-9	RESTRICTED TO -
APPLICATION SPEC -	WEIGHT 0.036g	SCALE NTS	SHEET 1 OF 1	REV B
CUSTOMER DRAWING				