

CM0805C221R-10

PHYSICAL DIMENSIONS:

A	2.00 [.079]	+ 0.20 [.008]
B	1.20 [.047]	+ 0.20 [.008]
C	1.20 [.047]	+ 0.20 [.008]
D	0.15 [.006]	+ 0.10 [.004]

T1	0.55 [.022]	+ 0.10 [.004]
T2	0.46 [.018]	+ 0.10 [.004]

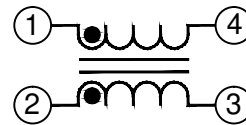
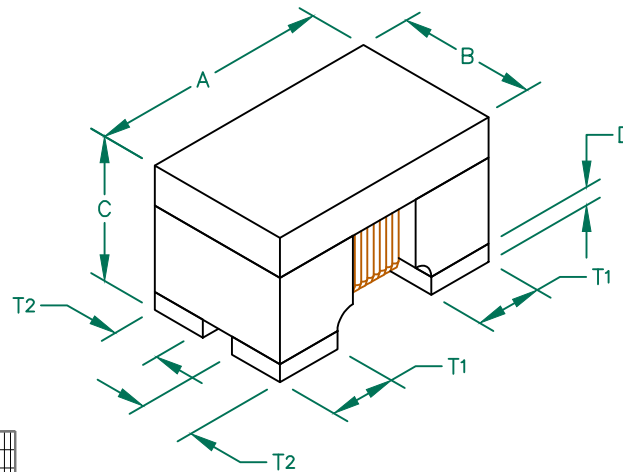

LAND PATTERNS FOR REFLOW SOLDERING

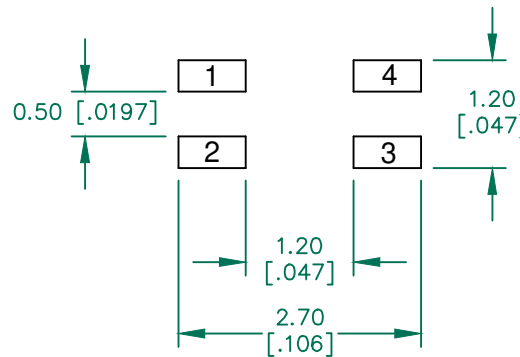

Electrical Characteristics		Nominal	Min	Max
Common Mode Impedance @ 100MHz	(Ω)	220	165	275
DCR	(Ω)	-	-	0.4
Rated Current	(mA)	-	-	300

NOTES: UNLESS OTHERWISE SPECIFIED

1. TAPED AND REELED per CURRENT EIA SPECIFICATIONS 7" REELS, EMBOSSED PLASTIC TAPE 2,000 PCS/REEL.
2. TERMINATION FINISH 100% MATTE TIN.
3. COMPONENTS SHOULD BE ADEQUATELY PREHEATED BEFORE SOLDERING.
4. OPERATING TEMP. RANGE: $-40^{\circ}\text{C} \sim +125^{\circ}\text{C}$. (INCLUDING SELF-HEATING)
5. COSMETIC SPECIFICATION REFER TO WI-QA-124.

RECOMMENDED SOLDERING CONDITIONS

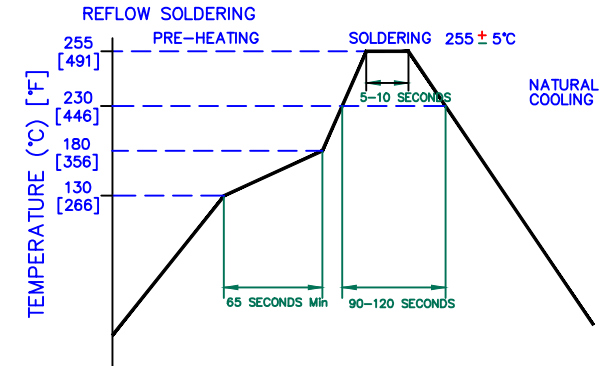

Z, R, XL vs. FREQUENCY

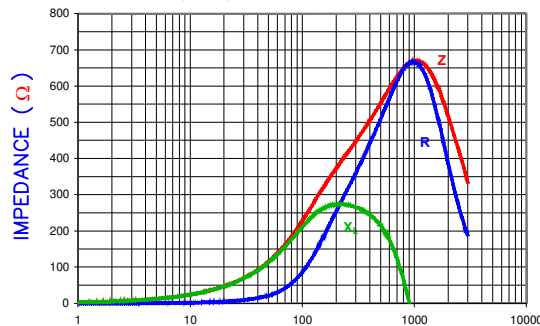

FREQUENCY (MHz)

Z R XL

Z vs. FREQUENCY (C,N,O)

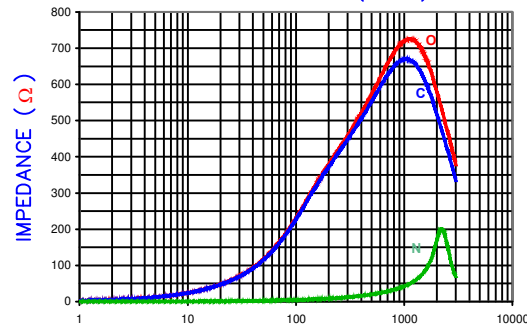

FREQUENCY (MHz)

Open Common Normal

RoHS

DIMENSIONS ARE IN mm [INCHES]				This print is the property of Laird Tech. and is loaned in confidence subject to return upon request and with the understanding that no copies shall be made without the written consent of Laird Tech. All rights to design or invention are reserved.	
E	ADD OPERATING TEMPERATURE UPDATE LAIRD LOGO AND REFLOW CURVE	08/05/13	QU	Laird PROJECT/PART NUMBER: CM0805C221R-10 REV: E PART TYPE: CM CHOKE DRAWN BY: JRK	
D	UPDATE T1 AND T2	01/15/10	JUN		
C	UPDATE COMPANY LOGO	04/28/09	JRK		
B	UPDATE COMPANY LOGO	05/10/07	JRK		
A	ORIGINAL DRAFT	08/11/06	JRK		
REV	DESCRIPTION	DATE	INT	DATE: 08/11/06	SCALE: NTS
				CAD #	TOOL #
				CM0805C221R-10-E	-