

FSA2457 — Dual DPDT, 5Ω Analog Data Switch

Features

- Low On Capacitance for Data Path: 12pF Typical
- Low On Resistance for Data Path: 5Ω Typical
- Low Power Quiescent Consumption: 1μA Maximum
- Wide -3db Bandwidth: > 160MHz
- Packaged in Green 16-Lead UMLP (1.8 x 2.6mm)
- 4kV JEDEC: JESD22-A114 HBM
- 2kV JEDEC: JESD22-C101 CDM

Applications

- Cell Phone, PDA, Digital Camera, Portable GPS
- LCD Monitor, TV, Set-Top Box

IMPORTANT NOTE:

For additional information, please contact analogswitch@fairchildsemi.com.

Description

The FSA2457 is a bi-directional, low-power, dual double-pole double-throw (4PDT) analog switch targeted at dual 1-bit SIM/SD/MMC card and/or GPS signal multiplexing. It is optimized for switching the WLAN-SIM data and control signals at 52Mbps.

The FSA2457 is compatible with the requirements of 1-bit SIM/SD/MMC cards and is ideal for interfacing to GPS baseband processors. The FSA2457 features a low on capacitance (C_{ON}) of 12pF to ensure high-speed data transfer.

The FSA2457 contains special circuitry that minimizes current consumption even when the control voltage applied to the SEL pin is lower than the supply voltage (V_{CC}). This feature is especially valuable in ultra-portable applications, such as cell phones; allowing direct interface with the general-purpose I/Os of the baseband processor. Other applications include switching and connector sharing in portable cell phones, PDAs, digital cameras, printers, and portable GPS systems.

Ordering Information

Part Number	Top Mark	 Eco Status	Operating Temperature Range	Package
FSA2457UMX	GD	Green	-40 to +85°C	16-Lead, Quad, Ultrathin Molded Leadless Package (UMLP), 1.8 x 2.6mm

 For Fairchild's definition of Eco Status, please visit: http://www.fairchildsemi.com/company/green/rohs_green.html.

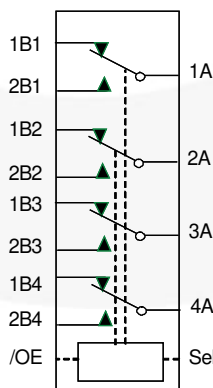

Figure 1. Analog Symbol

Pin Configuration

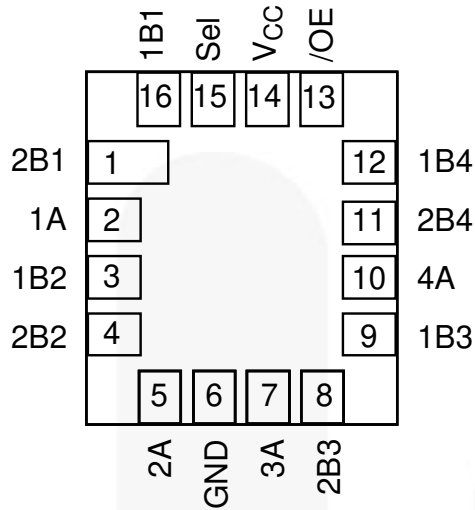

Figure 2. Pad Assignment UMLP16 (Top Through View)

Pin Definitions

Pin	Description
1Bn, 2Bn	Multiplexed Data Source Inputs
nA	Common Data Ports
Sel	Switch Select
/OE	Output Enable (Active LOW)

Truth Table

Sel	/OE	Function
Logic LOW	Logic LOW	1B1 = 1A, 1B2 = 2A, 1B3 = 3A, 1B4 = 4A
Logic HIGH	Logic LOW	2B1 = 1A, 2B2 = 2A, 2B3 = 3A, 2B4 = 4A
X	Logic HIGH	Data Ports Disconnected

Absolute Maximum Ratings

Stresses exceeding the absolute maximum ratings may damage the device. The device may not function or be operable above the recommended operating conditions and stressing the parts to these levels is not recommended. In addition, extended exposure to stresses above the recommended operating conditions may affect device reliability. The absolute maximum ratings are stress ratings only.

Symbol	Parameter	Min.	Max.	Unit
V_{CC}	Supply Voltage	-0.5	+4.6	V
V_{CNTRL}	DC Input Voltage (Sel, /OE) ⁽¹⁾	-0.5	+4.6	V
V_{SW}	DC Switch I/O Voltage ⁽¹⁾ 1Bn, 2Bn, nA	-0.5	$V_{CC} + 0.5$	V
I_{IK}	DC Input Diode Current	-50		mA
I_{OUT}	DC Output Current – V_{SW}		128	mA
T_{STG}	Storage Temperature	-65	+150	°C
MSL	Moisture Sensitivity Level (JEDEC J-STD-020A)		1	Level
ESD	Human Body Model, JEDEC: JESD22-A114	All Pins	4	kV
		I/O to GND	8	
	Charged Device Model, JEDEC: JESD22-C101		2	

Note:

- The input and output negative ratings may be exceeded if the input and output diode current ratings are observed.

Recommended Operating Conditions

The Recommended Operating Conditions table defines the conditions for actual device operation. Recommended operating conditions are specified to ensure optimal performance to the datasheet specifications. Fairchild does not recommend exceeding them or designing to Absolute Maximum Ratings.

Symbol	Parameter	Min.	Max.	Unit
V_{CC}	Supply Voltage	2.7	3.6	V
V_{CNTRL}	Control Input Voltage (Sel, /OE) ⁽²⁾	0	V_{CC}	V
V_{SW}	Switch I/O Voltage 1Bn, 2Bn, nA	-0.5	V_{CC}	V
I_{OUT}	DC Output Current 1Bn, 2Bn, nA		25	mA
T_A	Operating Temperature	-40	85	°C

Note:

- The control input must be held HIGH or LOW; it must not float.

DC Electrical Characteristics

All typical values are at 25°C, 3.3V V_{CC} unless otherwise specified.

Symbol	Parameter	Conditions	V_{CC} (V)	$T_A = -40^{\circ}\text{C to } +85^{\circ}\text{C}$			Units
				Min.	Typ.	Max.	
V_{IK}	Clamp Diode Voltage	$I_{IN} = -18\text{mA}$	2.7			-1.2	V
V_{IH}	Input Voltage High		2.7 to 3.0	1.8			V
			3.3 to 3.6	2.0			
V_{IL}	Input Voltage Low		2.7 to 3.6			0.8	V
I_{IN}	Control Input Leakage (Sel)	$V_{SW} = 0 \text{ to } V_{CC}$	3.6	-1		1	μA
$I_{nc(off)},$ $I_{no(off)}$	Off State Leakage	1Bn, 2Bn = 0V or V_{CC} Figure 4	3.6	-1		1	μA
R_{ON}	Data Path Switch On Resistance ⁽³⁾	$V_{SW} = 0, 2.0\text{V}, I_{ON} = -20\text{mA}$ Figure 3, Figure 12	2.7		5.0	7.0	Ω
ΔR_{ON}	Data Path Delta On Resistance ⁽⁴⁾	$V_{SW} = 0\text{V}, I_{ON} = -20\text{mA}$	2.7		0.3		Ω
I_{CC}	Quiescent Supply Current	$V_{CNTRL} = 0 \text{ or } V_{CC}, I_{OUT} = 0$	3.6			1.0	μA

Notes:

- Measured by the voltage drop between nB0, 1Bn and relative common port pins at the indicated current through the switch. On resistance is determined by the lower voltage on the relative ports.
- Guaranteed by characterization.

AC Electrical Characteristics

All typical value are for $V_{CC} = 3.3V$ at $25^{\circ}C$ unless otherwise specified.

Symbol	Parameter	Conditions	V_{CC} (V)	$T_A = -40^{\circ}C$ to $+85^{\circ}C$			Units
				Min.	Typ.	Max.	
t_{ON}	Turn-On Time Sel or /OE to Output (nA)	$R_L = 50\Omega$, $C_L = 30pF$ $V_{SW} = 1.5V$ Figure 5, Figure 6	2.7 to 3.6			7.0	ns
t_{OFF}	Turn-Off Time Sel or /OE to Output (nA)	$R_L = 50\Omega$, $C_L = 30pF$ $V_{SW} = 1.5V$ Figure 5, Figure 6	2.7 to 3.6			4.0	ns
O_{IRR}	Off Isolation ⁽⁵⁾ (nA)	$R_L = 50\Omega$, $f = 25MHz$, $C_L = 30pF$ Figure 9, Figure 13	2.7 to 3.6		-45		dB
Xtalk	Non-Adjacent Channel Crosstalk ⁽⁵⁾ (nA)	$R_L = 50\Omega$, $f = 25MHz$, $C_L = 30pF$ Figure 7	2.7 to 3.6		-54		dB
BW	-3db Bandwidth ⁽⁵⁾ (nA)	$R_L = 50\Omega$, $C_L = 30pF$ Figure 8, Figure 14	2.7 to 3.6		>160		MHz

Note:

5. Guaranteed by characterization.

Capacitance

Symbol	Parameter	Conditions	$T_A = -40^{\circ}C$ to $+85^{\circ}C$			Units
			Min.	Typ.	Max.	
C_{IN}	Control Pin Input Capacitance	$V_{CC} = 0V$		1.8		pF
C_{ON}	On Capacitance ⁽⁶⁾ (nA)	$V_{CC} = 3.3V$, $f = 1MHz$ Figure 10		12.0		pF
C_{OFF}	Off Capacitance ⁽⁶⁾ (nA)	$V_{CC} = 3.3V$ Figure 9		6.0		pF

Note:

6. Guaranteed by characterization.

Test Diagrams

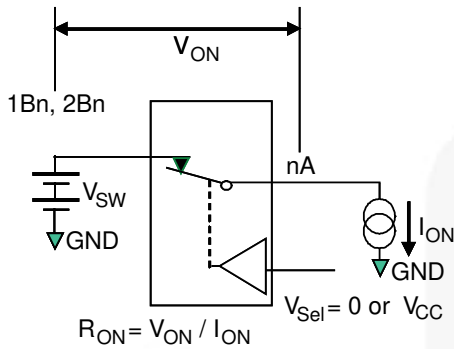

Figure 3. On Resistance

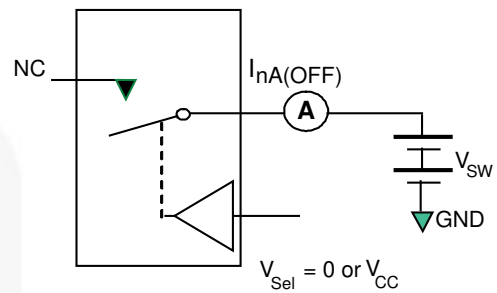
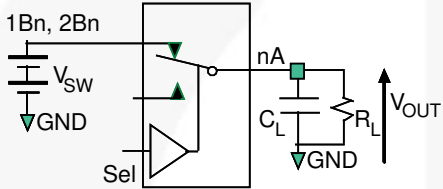

Figure 4. Off Leakage



R_L and C_L are functions of the application environment (see tables for specific values). C_L includes test fixture and stray capacitance.

Figure 5. AC Test Circuit Load

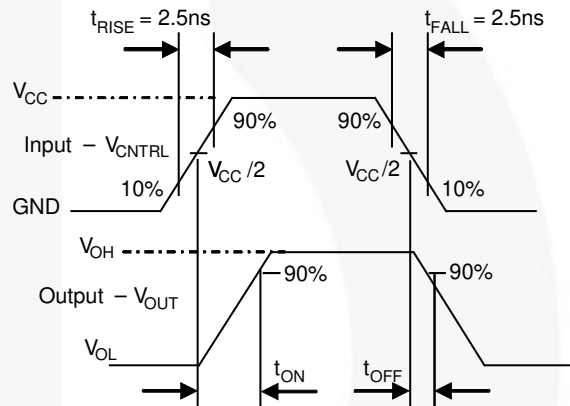
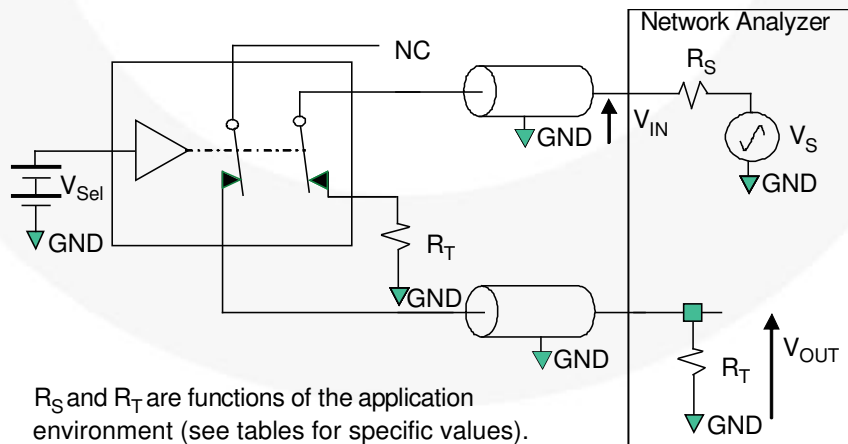

Figure 6. Turn-On / Turn-Off Waveforms



R_S and R_T are functions of the application environment (see tables for specific values).

$$\text{Crosstalk} = 20 \text{ Log} (V_{\text{OUT}} / V_{\text{IN}})$$

Figure 7. Non-Adjacent Channel-to-Channel Crosstalk

Test Diagrams (Continued)

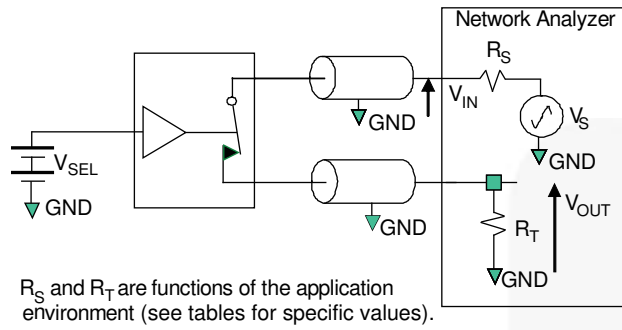

Figure 8. Bandwidth

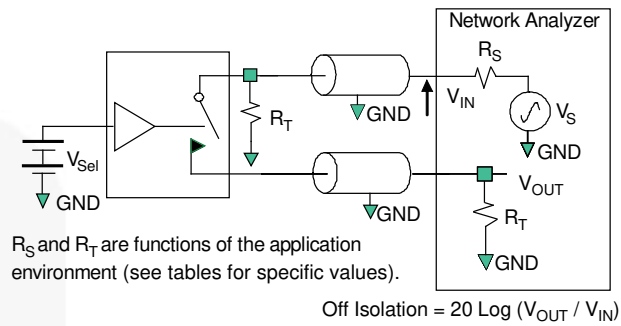

Figure 9. Channel Off Isolation

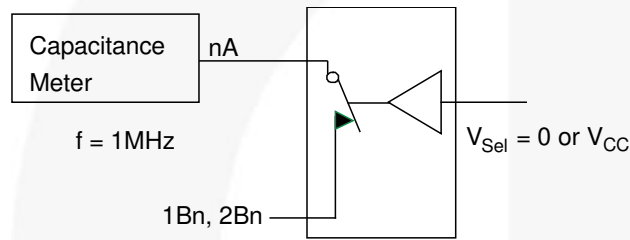

Figure 10. Channel On Capacitance

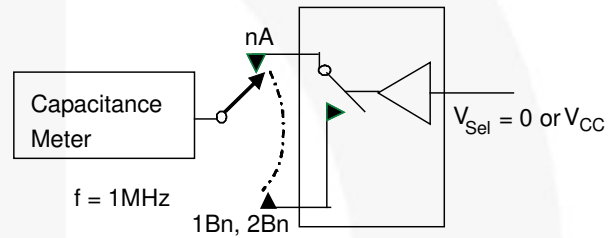

Figure 11. Channel Off Capacitance

Typical Performance Characteristics

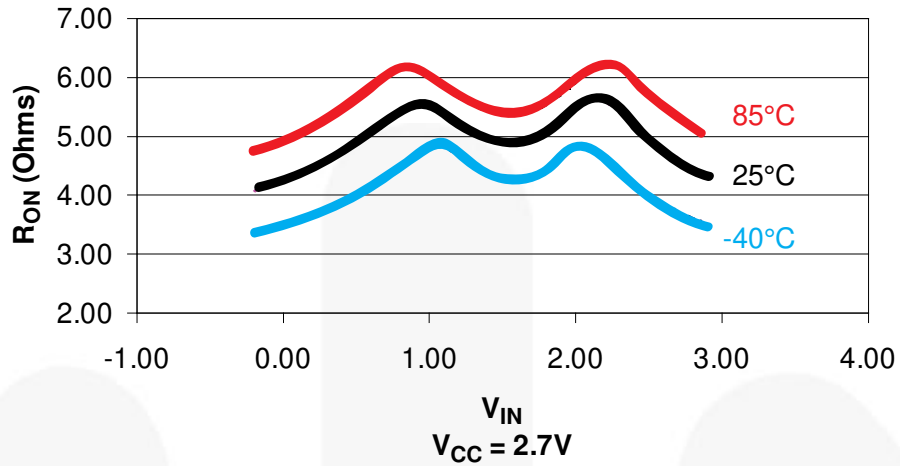

Figure 12. R_{ON}

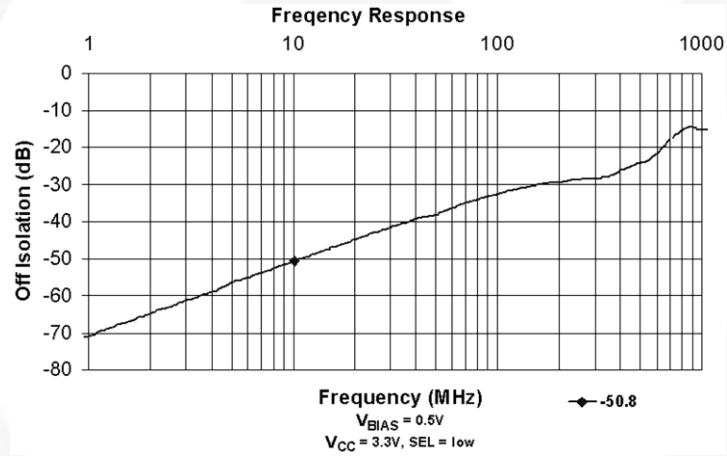

Figure 13. Off Isolation

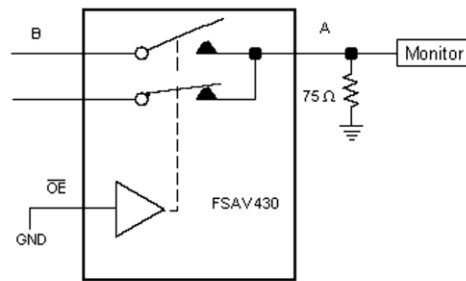
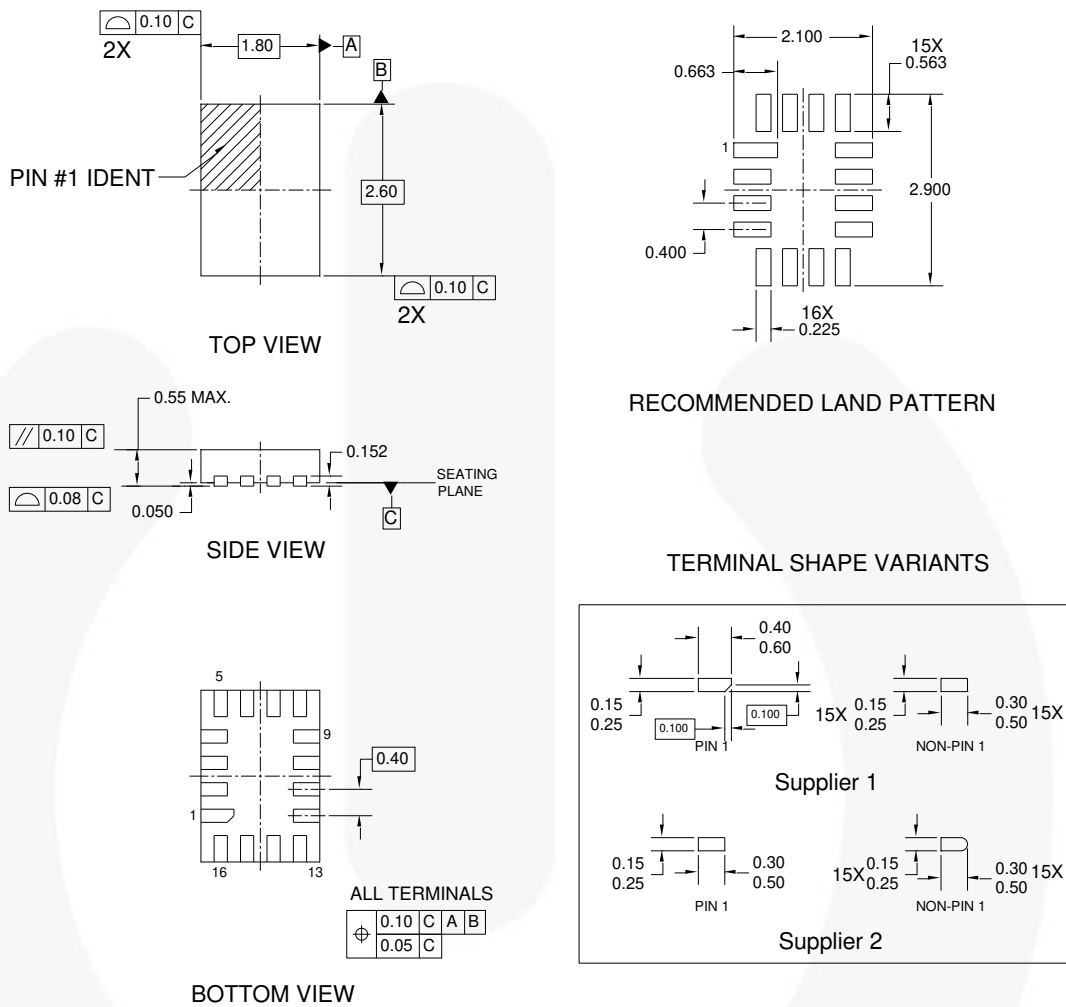

Figure 14. Bandwidth

Physical Dimensions



NOTES:

- A. THIS PACKAGE IS NOT CURRENTLY REGISTERED WITH ANY STANDARDS COMMITTEE
- B. DIMENSIONS ARE IN MILLIMETERS.
- C. DIMENSIONS AND TOLERANCES PER ASME Y14.5M, 1994
- D. TERMINAL SHAPE MAY VARY ACCORDING TO PACKAGE SUPPLIER, SEE TERMINAL SHAPE VARIANTS
- E. LAND PATTERN IS A MINIMAL TOE DESIGN
- F. DRAWING FILE NAME : UMLP16AREV3

Figure 15. 16-Lead Ultrathin Molded Leadless Package (UMLP)







Package drawings are provided as a service to customers considering Fairchild components. Drawings may change in any manner without notice. Please note the revision and/or date on the drawing and contact a Fairchild Semiconductor representative to verify or obtain the most recent revision. Package specifications do not expand the terms of Fairchild's worldwide terms and conditions, specifically the warranty therein, which covers Fairchild products.

Always visit Fairchild Semiconductor's online packaging area for the most recent package drawings:

<http://www.fairchildsemi.com/packaging/>

TRADEMARKS

The following includes registered and unregistered trademarks and service marks, owned by Fairchild Semiconductor and/or its global subsidiaries, and is not intended to be an exhaustive list of all such trademarks.

- | | | | |
|---|---|---|---|
| AccuPower™ | FPS™ | PowerTrench® | The Power Franchise® |
| Auto-SPM™ | F-PFST™ | PowerXS™ | the power franchise |
| Build it Now™ | FRFET® | Programmable Active Droop™ | TinyBoost™ |
| CorePLUS™ | Global Power Resource™ | QFET® | TinyBuck™ |
| CorePOWER™ | Green FPS™ | QS™ | TinyCalc™ |
| CROSSVOL7™ | Green FPS™ e-Series™ | Quiet Series™ | TinyLogic® |
| CTL™ | Gmax™ | RapidConfigure™ | TINYOPTO™ |
| Current Transfer Logic™ | GTO™ |  ™ | TinyPower™ |
| EcoSPARK® | IntelliMAX™ | Saving our world, 1mW/W/kW at a time™ | TinyPWM™ |
| EfficientMax™ | ISOPLANAR™ | SignalWise™ | TinyWire™ |
| EZSWITCH™ | MegaBuck™ | SmartMax™ | TriFault Detect™ |
|  ™ | MICROCOPPLER™ | SMART START™ | TRUECURRENT™ |
|  ™ | MicroFET™ | SPM® | μSerDes™ |
| Fairchild® | MicroPak™ | STEALTH™ |  ™ |
| Fairchild Semiconductor® | MillerDrive™ | SuperFET™ | UHC® |
| FACT Quiet Series™ | MotionMax™ | SuperSOT™-3 | Ultra FRFET™ |
| FACT® | Motion-SPM™ | SuperSOT™-8 | UniFET™ |
| FAST® | OPTOLOGIC® | SupreMOS™ | VCX™ |
| FastvCore™ | OPTOPLANAR® | SyncFET™ | VisualMax™ |
| FETBench™ |  ™ | Sync-Lock™ | XS™ |
| FlashWriter® | PDP SPM™ |  ™ | |
| | Power-SPM™ | | |

* Trademarks of System General Corporation, used under license by Fairchild Semiconductor.

DISCLAIMER

FAIRCHILD SEMICONDUCTOR RESERVES THE RIGHT TO MAKE CHANGES WITHOUT FURTHER NOTICE TO ANY PRODUCTS HEREIN TO IMPROVE RELIABILITY, FUNCTION, OR DESIGN. FAIRCHILD DOES NOT ASSUME ANY LIABILITY ARISING OUT OF THE APPLICATION OR USE OF ANY PRODUCT OR CIRCUIT DESCRIBED HEREIN; NEITHER DOES IT CONVEY ANY LICENSE UNDER ITS PATENT RIGHTS, NOR THE RIGHTS OF OTHERS. THESE SPECIFICATIONS DO NOT EXPAND THE TERMS OF FAIRCHILD'S WORLDWIDE TERMS AND CONDITIONS, SPECIFICALLY THE WARRANTY THEREIN, WHICH COVERS THESE PRODUCTS.

LIFE SUPPORT POLICY

FAIRCHILD'S PRODUCTS ARE NOT AUTHORIZED FOR USE AS CRITICAL COMPONENTS IN LIFE SUPPORT DEVICES OR SYSTEMS WITHOUT THE EXPRESS WRITTEN APPROVAL OF FAIRCHILD SEMICONDUCTOR CORPORATION.

As used herein:

1. Life support devices or systems are devices or systems which, (a) are intended for surgical implant into the body or (b) support or sustain life, and (c) whose failure to perform when properly used in accordance with instructions for use provided in the labeling, can be reasonably expected to result in a significant injury of the user.
2. A critical component in any component of a life support device, or system whose failure to perform can be reasonably expected to cause the failure of the life support device or system, or to affect its safety or effectiveness.

ANTI-COUNTERFEITING POLICY

Fairchild Semiconductor Corporation's Anti-Counterfeiting Policy. Fairchild's Anti-Counterfeiting Policy is also stated on our external website, www.fairchildsemi.com, under Sales Support.

Counterfeiting of semiconductor parts is a growing problem in the industry. All manufacturers of semiconductor products are experiencing counterfeiting of their parts. Customers who inadvertently purchase counterfeit parts experience many problems such as loss of brand reputation, substandard performance, failed applications, and increased cost of production and manufacturing delays. Fairchild is taking strong measures to protect ourselves and our customers from the proliferation of counterfeit parts. Fairchild strongly encourages customers to purchase Fairchild parts either directly from Fairchild or from Authorized Fairchild Distributors who are listed by country on our web page cited above. Products customers buy either from Fairchild directly or from Authorized Fairchild Distributors are genuine parts, have full traceability, meet Fairchild's quality standards for handling and storage and provide access to Fairchild's full range of up-to-date technical and product information. Fairchild and our Authorized Distributors will stand behind all warranties and will appropriately address any warranty issues that may arise. Fairchild will not provide any warranty coverage or other assistance for parts bought from Unauthorized Sources. Fairchild is committed to combat this global problem and encourage our customers to do their part in stopping this practice by buying direct or from authorized distributors.

PRODUCT STATUS DEFINITIONS

Definition of Terms

Datasheet Identification	Product Status	Definition
Advance Information	Formative / In Design	Datasheet contains the design specifications for product development. Specifications may change in any manner without notice.
Preliminary	First Production	Datasheet contains preliminary data; supplementary data will be published at a later date. Fairchild Semiconductor reserves the right to make changes at any time without notice to improve design.
No Identification Needed	Full Production	Datasheet contains final specifications. Fairchild Semiconductor reserves the right to make changes at any time without notice to improve the design.
Obsolete	Not In Production	Datasheet contains specifications on a product that is discontinued by Fairchild Semiconductor. The datasheet is for reference information only.

Rev. 142