

THIS DRAWING IS UNPUBLISHED. RELEASED FOR PUBLICATION
 © COPYRIGHT BY TYCO ELECTRONICS CORPORATION. ALL RIGHTS RESERVED.

DESIGNED FOR USE WITH RG-142/U FLEX CABLE CABLE ENTRY DIAMETER MINIMUM	
FERRULE	.216
CONTACT	.040
HOUSING	.119

LOC	DIST	REVISIONS					
AJ	00	P	LTR	DESCRIPTION	DATE	DWN	APVD
		B		REV PER ECO 07-004710	3/12/2007	DW	KW

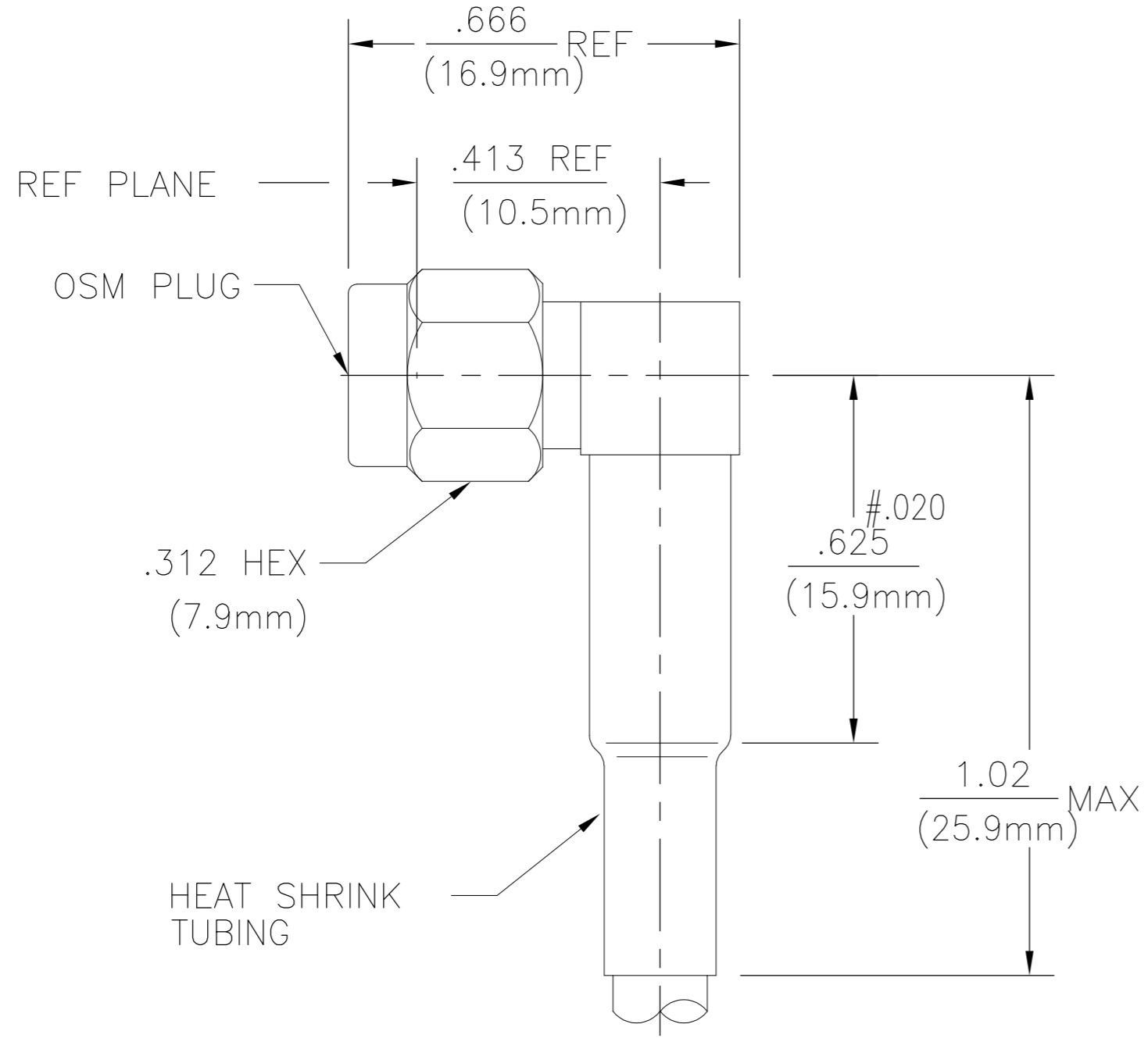

1052063-1
PART NUMBER

HOUSING CAP	STAINLESS STEEL PER ASTM-A484 AND ASTM-A582, TYPE 303	GOLD PLATE PER MIL-G-45204 OVER NICKEL PLATE PER QQ-N-290
COUPLING NUT	STAINLESS STEEL PER ASTM-A484 AND ASTM-A582, TYPE 303	PASSIVATE PER ASTM-A380
DIELECTRIC	TFE FLUOROCARBON PER ASTM-D-1457	N/A
CENTER CONTACT	BERYLLIUM COPPER PER ASTM B 196, ALLOY C17300, CONDITION H OR BRASS PER ASTM-B-16	GOLD PLATE PER MIL-G-45204 OVER COPPER PLATE PER MIL-C-14550
RETAINING RING	BERYLLIUM COPPER PER ASTM B 194, ALLOY C17200, CONDITION H	N/A
GASKET	SILICONE RUBBER PER ZZ-R-765	N/A
SHRINK TUBING	HEAT SHRINKABLE POLYOLEFIN COMPOUND MIL-I-23053/4	N/A
FERRULE	COPPER OR BRASS ALLOY ROCKWELL F65 MAXIMUM	GOLD PLATE PER MIL-G-45204 OVER COPPER PLATE PER MIL-C-14550
COMPONENT	MATERIAL	FINISH

ELECTRICAL	MECHANICAL	ENVIRONMENTAL
Nominal Impedance (Ohms) 50	Interface Dimensions MIL-STD-348A, Fig. 310.1	TEMPERATURE RATING -65°C TO +125°C
Frequency Range (GHz) DC 12.4	Recommended Mating Torque 7-10 In-Lbs	Vibration MIL-STD-202, Method 204, Condition D
Volt Rating (VRMS MAX) @ Sea Level 335	Mating Characteristics:	Shock MIL-STD-202, Method 213, Condition I
VSWR 1.15+.01f(GHz)	Insertion (MAX Lbs) N/A	Thermal Shock MIL-STD-202, Method 107, Condition B, EXCEPT HIGH TEMP +85°C
Insertion Loss (dB MAX) .07 f(GHz)	Withdrawal (MIN Oz) N/A	Moisture Resistance MIL-STD-202, Method 106, No Measurements at High Humidity
RF Leakage (dB MIN) -(60-fGHz)	Force to Engage and Disengage (In-Lbs MAX) 2.0	Corrosion - MIL-STD-202, Method 101, Condition B, 5% salt spray
Corona, 70,000 Ft (VRMS MIN) 250	Center Contact Captivation Axial (Lbs) 6.0	
Dielectric Withstanding Voltage (VRMS MIN) @ Sea Level 1000	Radial (In-Oz) 4.0	
Contact Resistance (Milliohms MAX) Center Contact 3.0	Cable Retention Axial Force (Lbs) 40 Min	
Outer Contact 2.0	Torque (In-Oz) N/A	
Cable to Housing 0.5	Weight (Grams) TBD	
RF High Potential @ Sea Level (VRMS MIN @ 5 MHz) 670		
I.R.(Megohms MIN) 10000		

THIS DRAWING IS A CONTROLLED DOCUMENT.

DWN PAO	8/13/74	 Tyco Electronics Corporation Harrisburg, PA 17105-3608
CHK PW	8/16/74	
APVD PW	8/16/74	
NAME		
DIMENSIONS: INCHES	TOLERANCES UNLESS OTHERWISE SPECIFIED:	PRODUCT SPEC
0 PLC ± -	1 PLC ± -	APPLICATION SPEC
2 PLC ± -	3 PLC ± .005	WEIGHT
4 PLC ± -	ANGLES ± 1°	SCALE 3:1
MATERIAL -	FINISH -	SHEET 1 of 1

OSM RIGHT ANGLE CABLE PLUG-SOLDER ATTACHMENT

SIZE A2 CAGE CODE 00779 DRAWING NO C=1052063 RESTRICTED TO -

CUSTOMER DRAWING