

図面番号 (DRAWING NO.) SJ105454

版数 VER.	年月日 DATE	CN NO.	変更内容 DESCRIPTION	製図 DR.	担当 CHK.	査閲 APPD.	承認 APPD.
2	12/NOV/2007	064189	REVISED FORM OF SCREW	—	T. TAKESHITA	—	E. MATSUMOTO
3	31/JUL/2008	066307	ADD A MARK	—	H. NAKAJIMA	T. OKAMURA	E. MATSUMOTO
4	22/JAN/2016	016004	CHANGE A COLOR OF WASHER etc	—	T. NAKAMURA	T. SUZUKI	H. EBIHARA

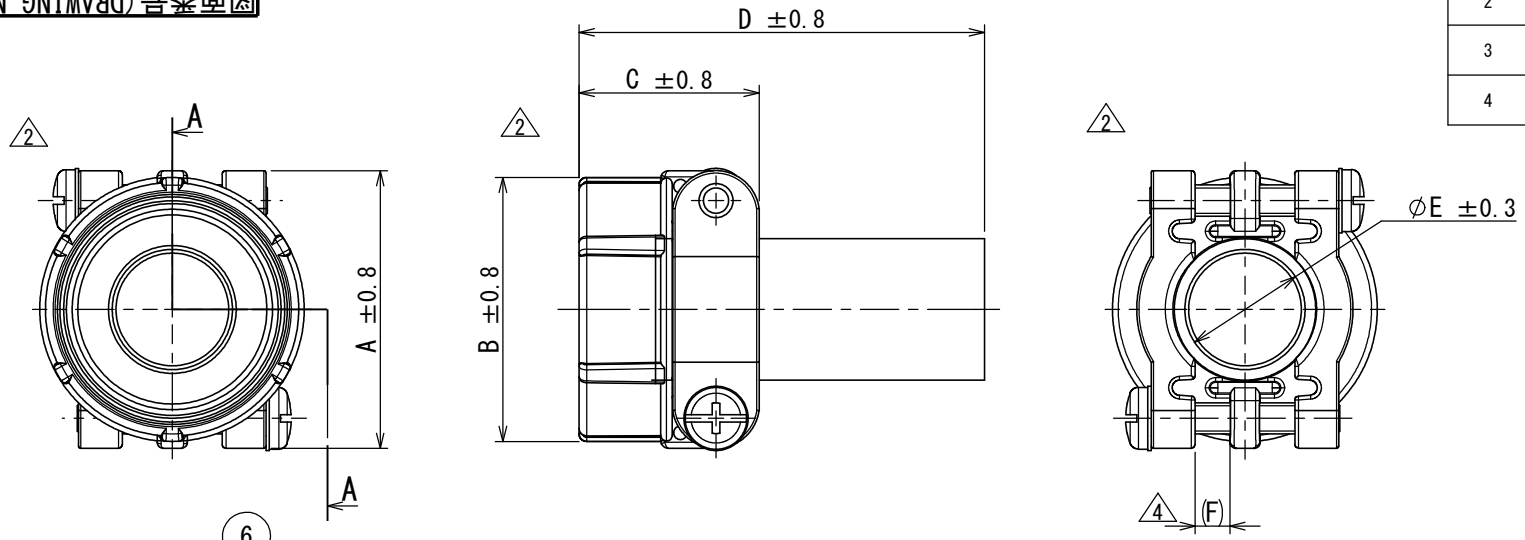

**DESIGNATION**  
命名法

JL04-\*\*CK(※)-CR-R

SERIES シリーズ名  
SHELL SIZE 適合シェルサイズ  
1012:10S, 10SL,  
12, 12S SIZE  
18 :18 SIZE  
2022:20, 22 SIZE  
2428:24, 28 SIZE

SUFFIX 特殊記号  
MATERIAL OF BUSHING  
ブッシング材料  
APPLICABLE CABLE DIAMETER  
(SEE TABLE)  
適合ケーブル径  
CABLE CLAMP  
ケーブルクランプ

TABLE: DIMENSIONS

No.	ITEM	DIMENSIONS	A±0.8	B±0.8	C±0.8	D±0.8	φE±0.3	(F) <sub>4</sub>	W THREAD	APPLICABLE CABLE DIAMETER
1	JL04-1012CK (05)-CR-R		22.2	20.6	20.7	50.6	6	1.6	5/8-24UNEF-2B	φ4~φ6
2	JL04-1012CK (06)-CR-R		22.2	20.6	20.7	50.6	6.6	1.6	5/8-24UNEF-2B	φ4.6~φ6.6
3	JL04-18CK (07)-CR-R		31.8	30.2	24.1	53.8	8	3.2	1-20UNEF-2B	φ5~φ8
4	JL04-18CK (10)-CR-R		31.8	30.2	24.1	53.8	11	3.2	1-20UNEF-2B	φ8~φ11
5	JL04-18CK (13)-CR-R		31.8	30.2	24.1	53.8	14.1	3.2	1-20UNEF-2B	φ11~φ14.1
6	JL04-2022CK (09)-CR-R		37.3	34.9	24.3	53.8	9.5	4	1 3/16-18UNEF-2B	φ6.5~φ9.5
7	JL04-2022CK (12)-CR-R		37.3	34.9	24.3	53.8	13	4	1 3/16-18UNEF-2B	φ9.5~φ13
8	JL04-2022CK (14)-CR-R		37.3	34.9	24.3	53.8	16	4	1 3/16-18UNEF-2B	φ12.9~φ16
9	JL04-2428CK (11)-CR-R		42.9	42.1	26.2	56.2	12	4.8	1 7/16-18UNEF-2B	φ9~φ12
10	JL04-2428CK (14)-CR-R		42.9	42.1	26.2	56.2	15	4.8	1 7/16-18UNEF-2B	φ12~φ15
11	JL04-2428CK (17)-CR-R		42.9	42.1	26.2	56.2	18	4.8	1 7/16-18UNEF-2B	φ15~φ18
12	JL04-2428CK (20)-CR-R		42.9	42.1	26.2	56.2	21	4.8	1 7/16-18UNEF-2B	φ18~φ20

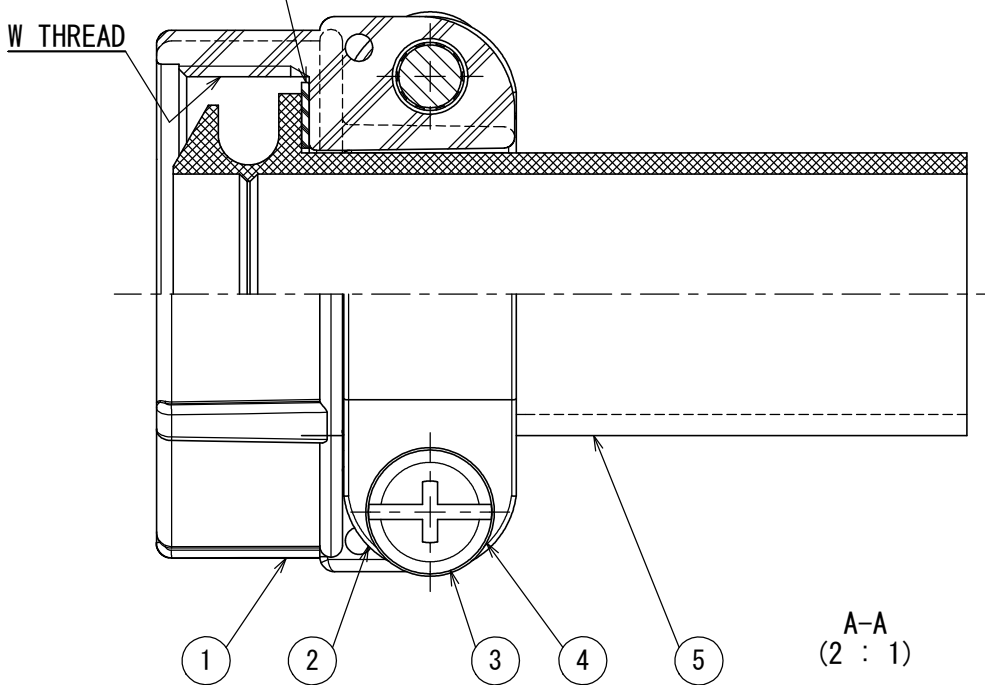

NOTE 1. THIS MATERIAL IS WATERPROOF CABLE CLAMP FOR CABTYRE CABLE.  
2. USE THIS MATERIAL ASSEMBLED WITH WATERPROOF TYPE ENDBELL.  
3. SEE ITEM DWG. OF WATERPROOF TYPE ENDBELL SHOWN RIGHT.

注1. 本部品は『防水型キャブタイヤ用ケーブルクランプ』です。  
2. 本部品は『防水型エンドベル』に取り付けて使用下さい。  
3. 『防水型エンドベル』右記の製品図番を参照下さい。

ENDBELL STYLE	ITEM DWG.
STRAIGHT	SJ105392
ANGLE (90°)	SJ105393

特別管理品目  
SPECIAL CONTROL ITEM  
TUV

符号 NO.	名称 DESCRIPTION	個数 QTY.	材料 MATERIAL	仕上 FINISH	備考 REMARKS
6	WASHER	1	SYNTHETIC RESIN	—	COLOR:BLACK or NATURAL <sub>4</sub>
5	BUSHING	1	CR	—	COLOR:DARK GREEN
4	WASHER	2	STEEL	ZINC PLATING	COLOR:BLACK SYSTEM INTERFERENCE COLOR
3	SCREW	2	COPPER ALLOY	ZINC PLATING	COLOR:BLACK SYSTEM INTERFERENCE COLOR
2	CLAMP SADDLE	2	ALUMINUM ALLOY	ZINC PLATING	COLOR:BLACK SYSTEM INTERFERENCE COLOR
1	GLAND NUT	1	ALUMINUM ALLOY	ZINC PLATING	COLOR:BLACK SYSTEM INTERFERENCE COLOR

仕様書 (SPECIFICATION)	第1版 (ORIGINAL DATE) 20/DEC/2005	尺度 (SCALE)	シリーズ (SERIES) JL04	日本航空電子工業株式会社
製図 DR. H. SAKURADA	担当 CHK. M. NITTA	名称 (TITLE) JL04-**CK(※)-CR-R	質量 (MASS)	JAPAN AVIATION ELECTRONICS INDUSTRY, LTD.
査閲 APPD. T. OKAMURA	承認 APPD. A. ONOGAWA	図面番号 (DRAWING NO.) SJ105454	版数 (VER.) 4	

DCF-C-212H(12.08)

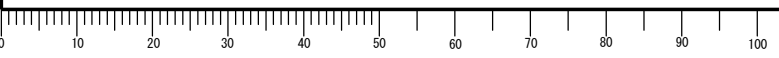

WISDOM承認 2016/01/22