



- 1
- 2
- 3
- 4
- 5
- 6
- 7
- 8
- 9
- 10
- 11
- 12
- 13
- 14
- 15
- 16
- 17
- 18

STANDARD EXECUTIONS

Brass bosses, threaded blind holes.

- **M.643**: high-resilience polypropylene based (PP) technopolymer, black colour, matte finish.
- **M.643R** (reduced version h=45): glass-fibre reinforced polyamide based (PA) technopolymer, black colour, matte finish.
- **M.643-FM**: high-resilience polypropylene based (PP) technopolymer, black colour, matte finish. Brass bosses, pass-through holes for cylindrical-head screws with hexagon socket.

TECHNICAL DATA

Tensile stress and impact strength: F1, F2, L1 and L2 values reported in the table are the result of breaking tests carried out with the appropriate dynamometric equipment under the test conditions shown in the figure with ambient temperature.

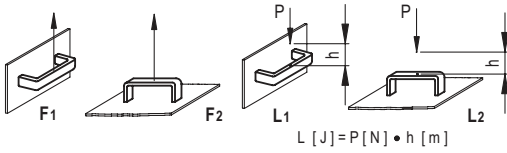

ELESA Original design

Conversion Table			
1 mm = 0,039 inch			
L			
mm	inch	mm	inch
100	3.94	177	6.97
108	4.25	196	7.72
134	5.28	209.5	8.17
148	5.83	253	9.96
166	6.53	322	12.68

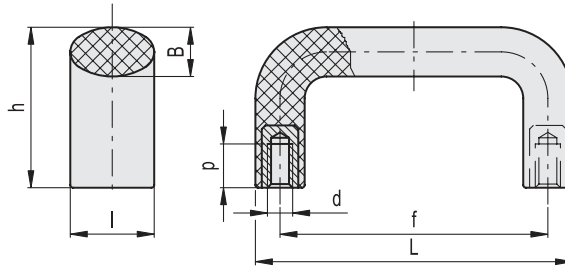

M.643



Code	Description	L	l	f	d6H	h	B	p	F1 [N]	F2 [N]	L1 [J]	L2 [J]	⚖️
37300	M.643/100 B-M5	100	23	86±0.5	M5	44	14	10	2400	2400	12	6	46
37301	M.643/100 B-M6	100	23	86±0.5	M6	44	14	12	2400	2400	12	6	45
37305	M.643/110 B-M5	108	24	94±0.5	M5	48	14	10	2300	2300	10	8	60
37306	M.643/110 B-M6	108	24	94±0.5	M6	48	14	12	2300	2300	10	8	59
37308	M.643/140-117 B-M4	134	25	117±0.5	M4	49	15	10	2250	2650	8	12	63
37309	M.643/140-117 B-M5	134	25	117±0.5	M5	49	15	10	2250	2650	8	12	64
37310	M.643/140-117 B-M6	134	25	117±0.5	M6	49	15	12	2250	2650	8	12	65
37311	M.643/140-117 B-M8	134	25	117±0.5	M8	49	15	13	2250	2650	8	12	67
37314	M.643/140-120 B-M5	134	25	120±0.5	M5	49	15	10	2250	2650	8	12	68
37315	M.643/140-120 B-M6	134	25	120±0.5	M6	49	15	12	2250	2650	8	12	69
37316	M.643/140-120 B-M8	134	25	120±0.5	M8	49	15	13	2250	2650	8	12	70
37320	M.643/150 B-M5	148	26	132±0.5	M5	53	16	10	2200	2450	8	12	71
37321	M.643/150 B-M6	148	26	132±0.5	M6	53	16	12	2200	2450	8	12	72
37322	M.643/150 B-M8	148	26	132±0.5	M8	53	16	13	2200	2450	8	12	73
37331	M.643/180 B-M6	166	27	150±1	M6	56	16	12	2000	2550	8	13	81
37332	M.643/180 B-M8	166	27	150±1	M8	56	16	13	2000	2550	8	13	82
37333	M.643/180 B-M10	166	27	150±1	M10	56	16	17	2000	2550	8	13	83
37341	M.643/190 B-M6	177	27	160±1	M6	55	16	12	2000	2250	8	13	90
37342	M.643/190 B-M8	177	27	160±1	M8	55	16	13	2000	2250	8	13	91
37343	M.643/190 B-M10	177	27	160±1	M10	55	16	17	2000	2250	8	13	92
37351	M.643/200 B-M8	196	27	179±1	M8	57	16	13	1900	2000	11	13	130
37352	M.643/200 B-M10	196	27	179±1	M10	57	16	17	1900	2000	11	13	132
37356	M.643/210 B-M8	209.5	28	192±1	M8	58	17	13	2000	2100	14	15	98
37357	M.643/210 B-M10	209.5	28	192±1	M10	58	17	17	2100	2100	14	15	97
37361	M.643/260 B-M8	253	29	235±1	M8	61	18.5	13	1900	2000	13	12	173
37362	M.643/260 B-M10	253	29	235±1	M10	61	18.5	17	1900	2000	13	12	171
37371	M.643/320 B-M10	322	32	300±1	M10	64	22	17	2000	2000	18	11	205



Conversion Table			
1 mm = 0,039 inch			
L			
mm	inch	mm	inch
100	3.94	148	5.83
134	5.28	196	7.72

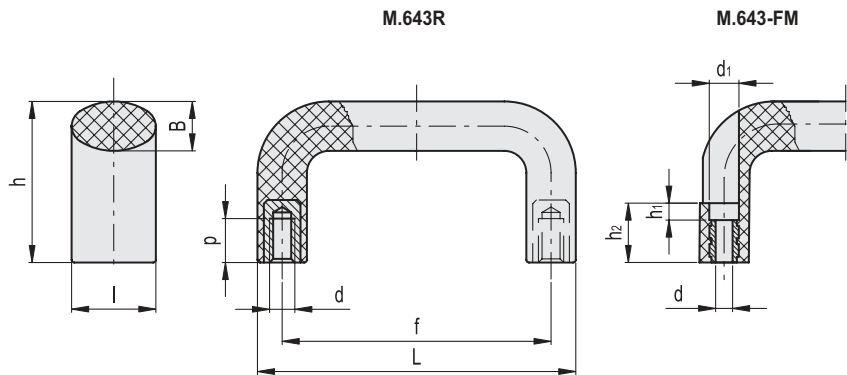

M.643R

METRIC

Code	Description	L	l	f	d6H	h	B	p	F1 [N]	F2 [N]	L1 [J]	L2 [J]	⚖️
37353	M.643R/200 B-M8	196	27	179±1	M8	45	15	13	4000	3500	25	25	118

M.643-FM

Code	Description	L	l	f	d	d1	h	h1	h2	B	F1 [N]	F2 [N]	L1 [J]	L2 [J]	⚖️
137301	M.643 FM/100 B-5	100	23	86±0.5	5.4	8.5	44	5.5	20.5	14	3000	2200	11	9	45
137311	M.643 FM/140 B-6	134	25	117±0.5	6.4	10.5	49	6	21	15	2000	2800	11	9	64
137331	M.643 FM/150 B-6	148	26	132±0.5	6.4	10.5	53	8.5	23.5	16	1900	1900	11	9	70
137351	M.643 FM/200 B-6	196	27	179±1	6.4	10.5	57	6	21	16	1900	1900	11	13	89