

THIS DRAWING IS UNPUBLISHED. RELEASED FOR PUBLICATION
 © COPYRIGHT - By - ALL RIGHTS RESERVED.

| REVISIONS | | | | | |
|-----------|-----|---------------------------|-----------|-----|------|
| P | LTR | DESCRIPTION | DATE | DWN | APVD |
| | B | REDRAWN PER 0720-0470-95 | 23JAN95 | LO | ME |
| | B1 | REVISED PER ECO-16-017419 | 15MAR2017 | RS | DR |

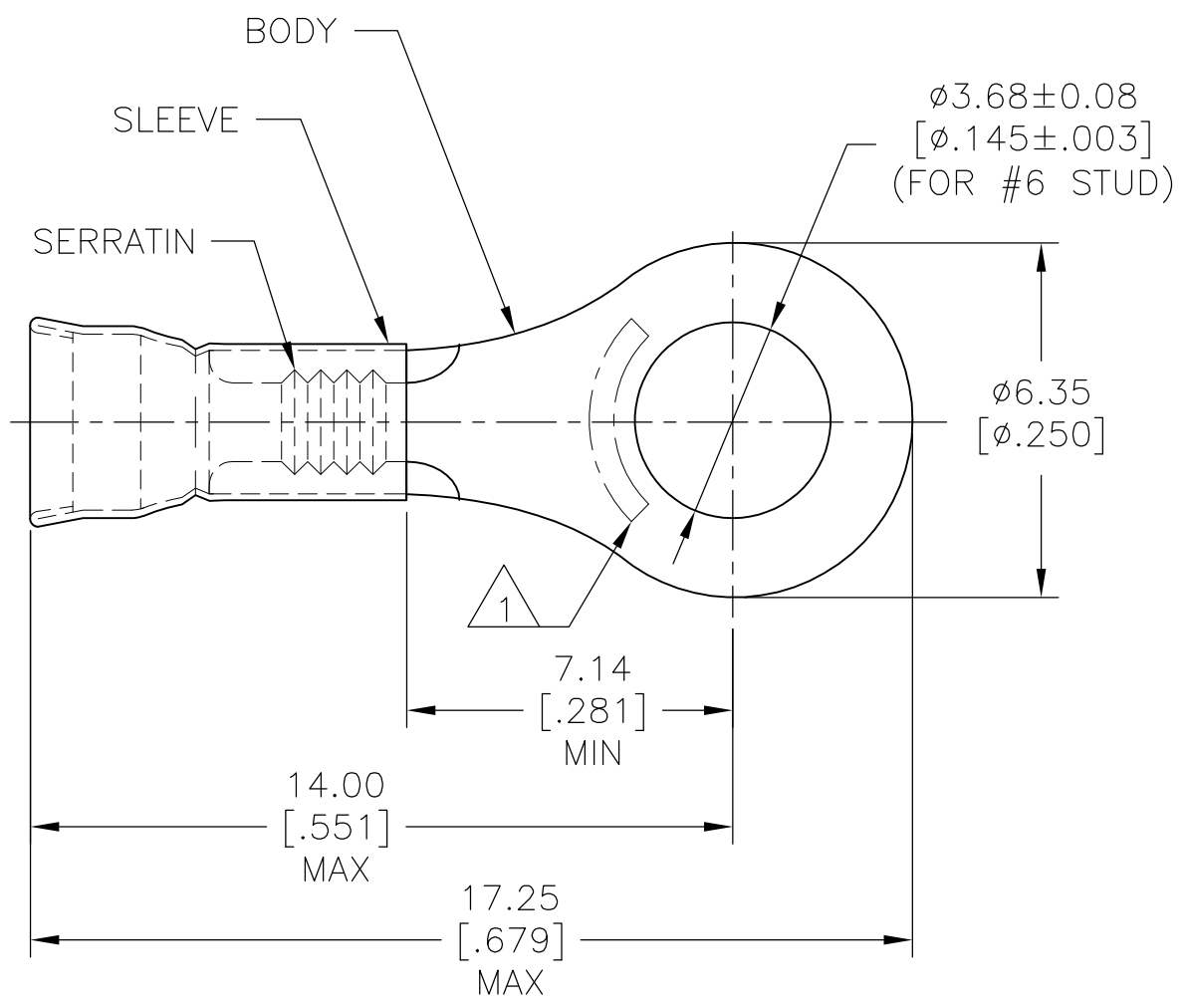

- 1 STAMP AMP LOCATE APPROX AS SHOWN.
- 2 WIRE INSUL DIA, $\phi 1.27-2.08$ [$\phi .050-.082$].
- 3 TONGUE MATL THK, 0.46 ± 0.05 [$.018\pm .002$].

| | | |
|------|--------------|---------|
| 1000 | LOOSE PIECE | 32861 |
| QTY | PACKAGE TYPE | PART NO |

| | | | | | | | | | | |
|--|--|---|--|--|---|---|----------|--------------|-----------------|------------------------------|
| AMP INCORPORATED CUSTOMER SERVICE SYSTEM | | MAX RECOMMENDED OPERATING TEMPERATURE: 170°C [338°F] | THIS DRAWING IS A CONTROLLED DOCUMENT. | | DWN L OLMEDA 23JAN95 | TE Connectivity NAME TERMINAL, RING, DIAMOND GRIP, WIRE SIZE, 26-22 AWG | | | | |
| FOR ADDITIONAL PRODUCT INFORMATION OR COPIES OF DRAWINGS AND TECHNICAL DOCUMENTS | PRODUCT INFORMATION CENTER 1-800-522-6752 | VOLTAGE RATING: - | DIMENSIONS: mm [INCHES] | TOLERANCES UNLESS OTHERWISE SPECIFIED: | CHK M ELLIS 23JAN95 | | | | | APVD S BORTNER 23JAN95 |
| FOR APPLICATION TOOLING INFORMATION | TOOLING ASSISTANCE CENTER 1-800-722-1111 | CIRCULAR MIL AREA: 0.10mm ² -0.41mm ² [202-810] STRANDED WIRE | | | 0 PLC ± - 1 PLC ± - 2 PLC ± 0.20 [.008] 3 PLC ± - 4 PLC ± - ANGLES ± - | FINISH | A3 00779 | | C=32861 | |
| FOR ORDER ENTRY | 1-800-526-5142 | MATERIAL BODY, CU, SLV, CU PER ASTM B152 | TIN PLATE PER MIL-T-10727 | | WEIGHT - | CUSTOMER DRAWING | | SCALE 6:1 | SHEET 1 OF 1 | REV B1 |