

## Enhanced Super I/O with LPC Interface for Server Applications

### PRODUCT FEATURES

Data Brief

- 3.3 Volt Operation (5V Tolerant)
- Floppy Disk Controller (Supports Two FDCs)
- Multi-Mode Parallel Port
- Two UARTs
- 8042 Keyboard Controller
- SMBus Controller
- X-Bus Interface
- Programmable Wakeup Event Interface (nIO\_PME Pin)
- SMI Support (nIO\_SMI Pin)
- GPIOs (39)
- Fan Speed Control Output
- Fan Tachometer Input
- ISA IRQ to Serial IRQ Conversion
- XNOR Chain
- PC99 and ACPI 1.0 Compliant
- ISA Plug-and-Play Compatible Register Set
- Intelligent Auto Power Management
- 2.88MB Super I/O Floppy Disk Controller
  - Licensed CMOS 765B Floppy Disk Controller
  - Software and Register Compatible with SMSC's Proprietary 82077AA Compatible Core
  - Configurable Open Drain/Push-Pull Output Drivers
  - Supports Vertical Recording Format
  - 16-Byte Data FIFO
  - 100% IBM® Compatibility
  - Detects All Overrun and Underrun Conditions
  - Sophisticated Power Control Circuitry (PCC) Including Multiple Powerdown Modes for Reduced Power Consumption
  - DMA Enable Logic
  - Data Rate and Drive Control Registers
  - 480 Address, up to 15 IRQ and Three DMA Options
- Enhanced Digital Data Separator
  - 2 Mbps, 1 Mbps, 500 Kbps, 300 Kbps, 250 Kbps Data Rates
  - Programmable Precompensation Modes
- Keyboard Controller
  - 8042 Software Compatible
  - 8-Bit Microcomputer
  - 2k Bytes of Program ROM
  - 256 Bytes of Data RAM
  - Four Open Drain Outputs Dedicated for Keyboard/Mouse Interface
  - Asynchronous Access to Two Data Registers and One Status Register
  - Supports Interrupt and Polling Access
  - 8-Bit Counter Timer
  - Port 92 Support
  - Fast Gate A20 and KRESET Outputs
- Serial Ports
  - Two Full Function Serial Ports
  - High Speed NS16C550 Compatible UARTs with Send/Receive 16-Byte FIFOs
  - Supports 230k and 460k Baud
  - Programmable Baud Rate Generator
  - Modem Control Circuitry
  - 480 Address and 15 IRQ Options
  - IrDA 1.0, HP-SIR, ASK IR Support
- Multi-Mode Parallel Port with ChiProtect™
  - Standard Mode IBM PC/XT®, PC/AT®, and PS/2™ Compatible Bidirectional Parallel Port
  - Enhanced Parallel Port (EPP) Compatible - EPP 1.7 and EPP 1.9 (IEEE 1284 Compliant)
  - IEEE 1284 Compliant Enhanced Capabilities Port (ECP)
  - ChiProtect Circuitry for Protection Against Damage Due to Printer Power-On
  - 480 Address, up to 15 IRQ and 3 DMA Options
  - Multiplexed Command, Address and Data Bus
  - 8-Bit I/O Transfers
  - 8-Bit DMA Transfers
  - 16-Bit Address Qualification
  - Serial IRQ Interface Compatible with Serialized IRQ Support for PCI Systems
  - Power Management Event (PME) Interface Pin
- 100 Pin, QFP lead-free RoHS compliant package

**ORDER NUMBER:****LPC47S422-MS FOR 100 PIN, QFP LEAD-FREE ROHS COMPLIANT PACKAGE**

80 ARKAY DRIVE, HAUPPAUGE, NY 11788 (631) 435-6000, FAX (631) 273-3123

Copyright © 2007 SMSC or its subsidiaries. All rights reserved.

Circuit diagrams and other information relating to SMSC products are included as a means of illustrating typical applications. Consequently, complete information sufficient for construction purposes is not necessarily given. Although the information has been checked and is believed to be accurate, no responsibility is assumed for inaccuracies. SMSC reserves the right to make changes to specifications and product descriptions at any time without notice. Contact your local SMSC sales office to obtain the latest specifications before placing your product order. The provision of this information does not convey to the purchaser of the described semiconductor devices any licenses under any patent rights or other intellectual property rights of SMSC or others. All sales are expressly conditional on your agreement to the terms and conditions of the most recently dated version of SMSC's standard Terms of Sale Agreement dated before the date of your order (the "Terms of Sale Agreement"). The product may contain design defects or errors known as anomalies which may cause the product's functions to deviate from published specifications. Anomaly sheets are available upon request. SMSC products are not designed, intended, authorized or warranted for use in any life support or other application where product failure could cause or contribute to personal injury or severe property damage. Any and all such uses without prior written approval of an Officer of SMSC and further testing and/or modification will be fully at the risk of the customer. Copies of this document or other SMSC literature, as well as the Terms of Sale Agreement, may be obtained by visiting SMSC's website at <http://www.smisc.com>. SMSC is a registered trademark of Standard Microsystems Corporation ("SMSC"). Product names and company names are the trademarks of their respective holders.

**SMSC DISCLAIMS AND EXCLUDES ANY AND ALL WARRANTIES, INCLUDING WITHOUT LIMITATION ANY AND ALL IMPLIED WARRANTIES OF MERCHANTABILITY, FITNESS FOR A PARTICULAR PURPOSE, TITLE, AND AGAINST INFRINGEMENT AND THE LIKE, AND ANY AND ALL WARRANTIES ARISING FROM ANY COURSE OF DEALING OR USAGE OF TRADE. IN NO EVENT SHALL SMSC BE LIABLE FOR ANY DIRECT, INCIDENTAL, INDIRECT, SPECIAL, PUNITIVE, OR CONSEQUENTIAL DAMAGES; OR FOR LOST DATA, PROFITS, SAVINGS OR REVENUES OF ANY KIND; REGARDLESS OF THE FORM OF ACTION, WHETHER BASED ON CONTRACT; TORT; NEGLIGENCE OF SMSC OR OTHERS; STRICT LIABILITY; BREACH OF WARRANTY; OR OTHERWISE; WHETHER OR NOT ANY REMEDY OF BUYER IS HELD TO HAVE FAILED OF ITS ESSENTIAL PURPOSE, AND WHETHER OR NOT SMSC HAS BEEN ADVISED OF THE POSSIBILITY OF SUCH DAMAGES.**

## General Description

The LPC47S422 is a 3.3V PC99 compliant Super I/O controller. The LPC47S422 implements the LPC interface, a pin reduced ISA interface which provides the same or better performance as the ISA/X-bus with a substantial savings in pins used. The part provides 39 GPIO pins, an SMBus controller, a fan speed control output, a fan tachometer input, four ISA IRQs that can be routed to any of the serial IRQs, and an X-Bus interface.

The LPC47S422 incorporates a keyboard interface, SMSC's true CMOS 765B floppy disk controller, advanced digital data separator, two 16C550 compatible UARTs, one Multi-Mode parallel port which includes ChiProtect circuitry plus EPP and ECP, and Intelligent Power Management. The true CMOS 765B core provides 100% compatibility with IBM PC/XT and PC/AT architectures in addition to providing data overflow and underflow protection. The SMSC advanced digital data separator incorporates SMSC's patented data separator technology, allowing for ease of testing and use. The on-chip UARTs are compatible with the NS16C550. The parallel port is compatible with IBM PC/AT architecture, as well as IEEE 1284 EPP and ECP. The LPC47S422 incorporates sophisticated power control circuitry (PCC). The PCC supports multiple low power down modes.

The LPC47S422 supports the ISA Plug-and-Play Standard (Version 1.0a) and provides the recommended functionality to support Windows '95/'98 and PC99. The I/O Address, DMA Channel and Hardware IRQ of each logical device in the LPC47S422 may be reprogrammed through the internal configuration registers. There are 480 I/O address location options, a Serialized IRQ interface, and three DMA channels.

## Block Diagram

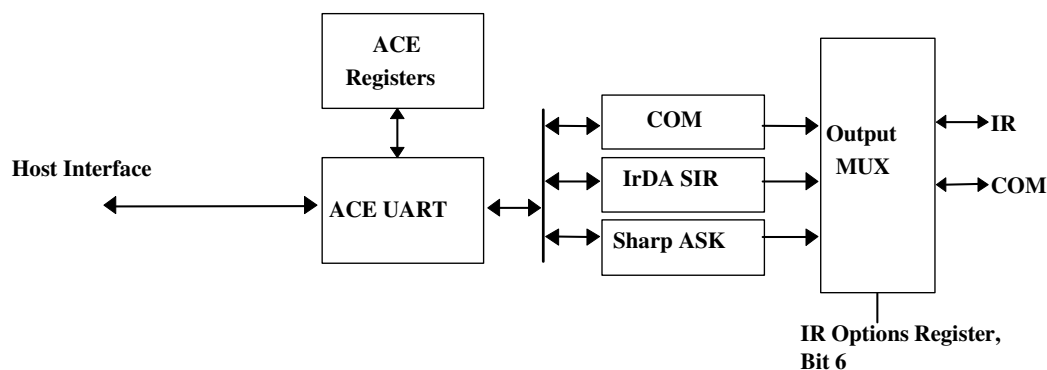
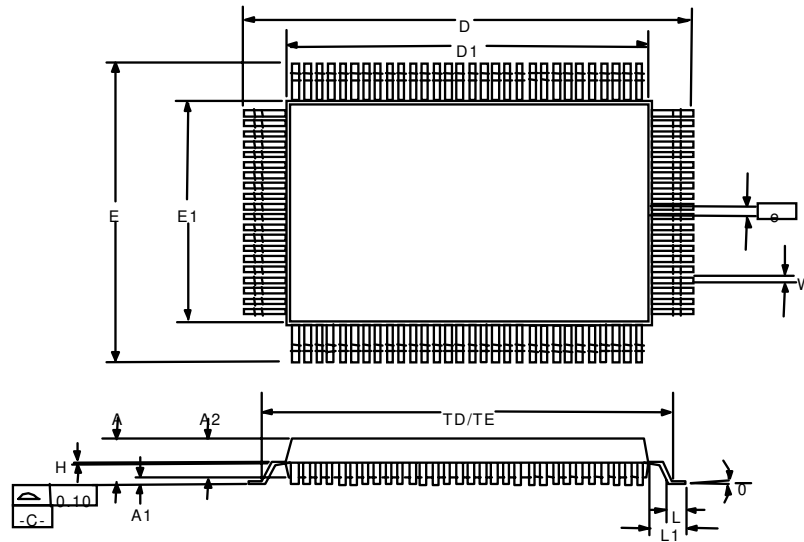

Figure 1 LPC47S422 Block Diagram

# Package Outline



DIM	MIN	MAX	MIN	MAX
A	2.80	3.15	.110	.124
A1	0.1	0.45	.004	.018
A2	2.57	2.87	.101	.113
D	23.4	24.15	.921	.951
D1	19.9	20.1	.783	.791
E	17.4	18.15	.685	.715
E1	13.9	14.1	.547	.555
H	0.1	0.2	.004	.008
L	0.65	0.95	.026	.037
L1	1.8	2.6	.071	.102
e	0.65 BSC		0.256 BSC	
$\theta$	0°	12°	0°	12°
W	.2	.4	.008	.016
TD(1)	21.8	22.2	.858	.874
TE(1)	15.8	16.2	.622	.638
TD(2)	22.21	22.76	.874	.896
TE(2)	16.27	16.82	.641	.662

**Notes:**

- 1) Coplanarity is 0.100mm (.004") maximum.
- 2) Tolerance on the position of the leads is 0.200mm (.008") maximum.
- 3) Package body dimensions D1 and E1 do not include the mold protrusion. Maximum mold protrusion is 0.25mm (.010").
- 4) Dimensions TD and TE are important for testing by robotic handler. Only above combinations of (1) or (2) are acceptable.
- 5) Controlling dimension: millimeter. Dimensions in inches for reference only and not necessarily accurate.

Figure 2 LPC47S422 100 Pin QFP Package Outline and Parameters