

Tous droits strictement réservés. Reproduction ou communication à des tiers interdite sous quelque forme que ce soit sans autorisation écrite du propriétaire. Propriété de c FCI. Droits de reproduction FCI.



All rights strictly reserved. Reproduction or issue to third parties in any form whatever is not permitted without written authority from the proprietor. Property of FCI. Copyright FCI.

PRODUCT NO.
SEE TABLE

1 | 2

3 |

4

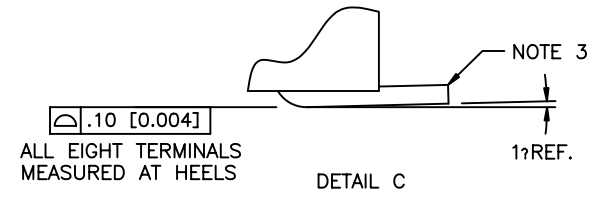
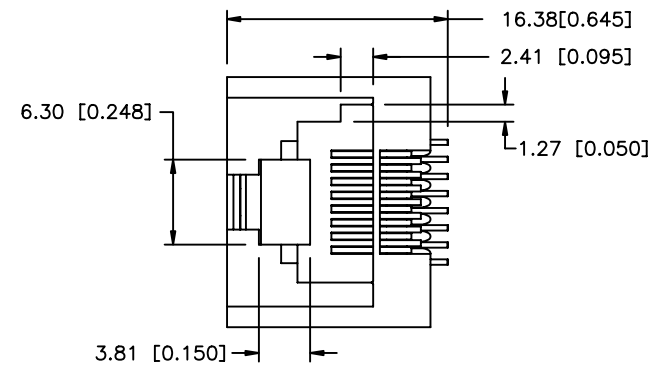

THE MYLAR SEE NOTE 7 ONLY FOR 87549-XXX1C/XXX1CLF

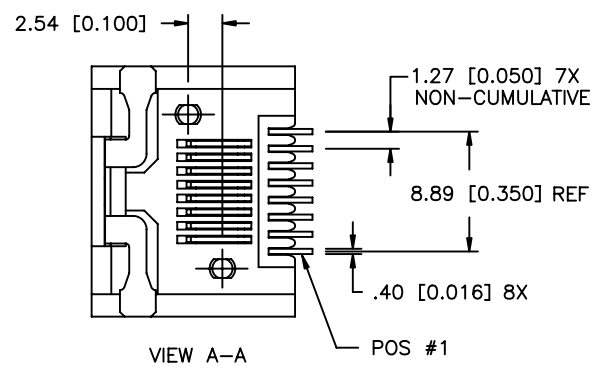
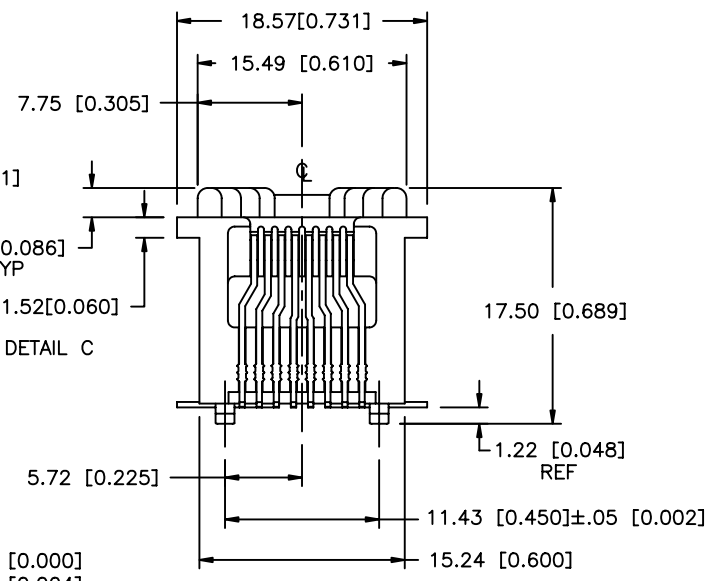
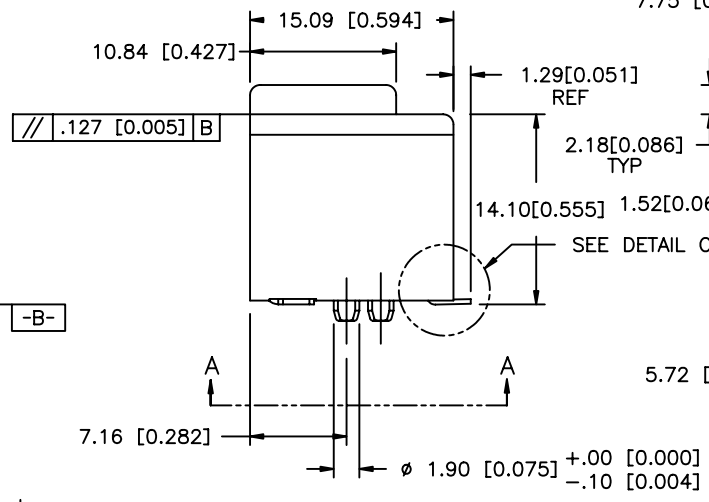
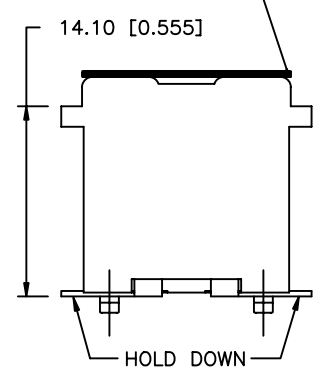

mat'l. code				tolerances unless otherwise specified			CUSTOMER COPY		FCI	
ltr	ecn no	dr	date	linear	.X±.3/.XX±.01	projection	title	A-SMT ASSEMBLY VERT 8 POS-KEYED		
M	N05-0035	YS	2/18/05		.XX±.13/.XXX±.005					
N	N08-0194	SH	9/08/08		.XXX±.051/.XXXX±.0020					
				angles	σ ±2°	M/INCH		product family	MOD JACK	code
K	V81474	GAH	9/15/96	dr	S.DUESTERHOEFT	3/20/96	scale	A4	87549	210
L	V12666	LP	1/10/02	enr	Y.BELOPOLSKY	3/20/96				
				chr	Y.BELOPOLSKY	7/8/96				
				appd	Y.BELOPOLSKY	7/8/96	1/1	sheet 1 of 2		
sheet index	revision sheet	N	N							
		1	2							

1 | 2

3 |

4

ACAD

PDM: Rev: N

STATUS: Released

Printed: Aug 01, 2010

Tous droits strictement réservés. Reproduction ou communication à des tiers interdite sous quelque forme que ce soit sans autorisation écrite du Propriétaire de c FCI. Droits de reproduction FCI.



All rights strictly reserved. Reproduction or issue to third parties in any form whatever is not permitted without written authority from the proprietor. Property of FCI. Copyright FCI.

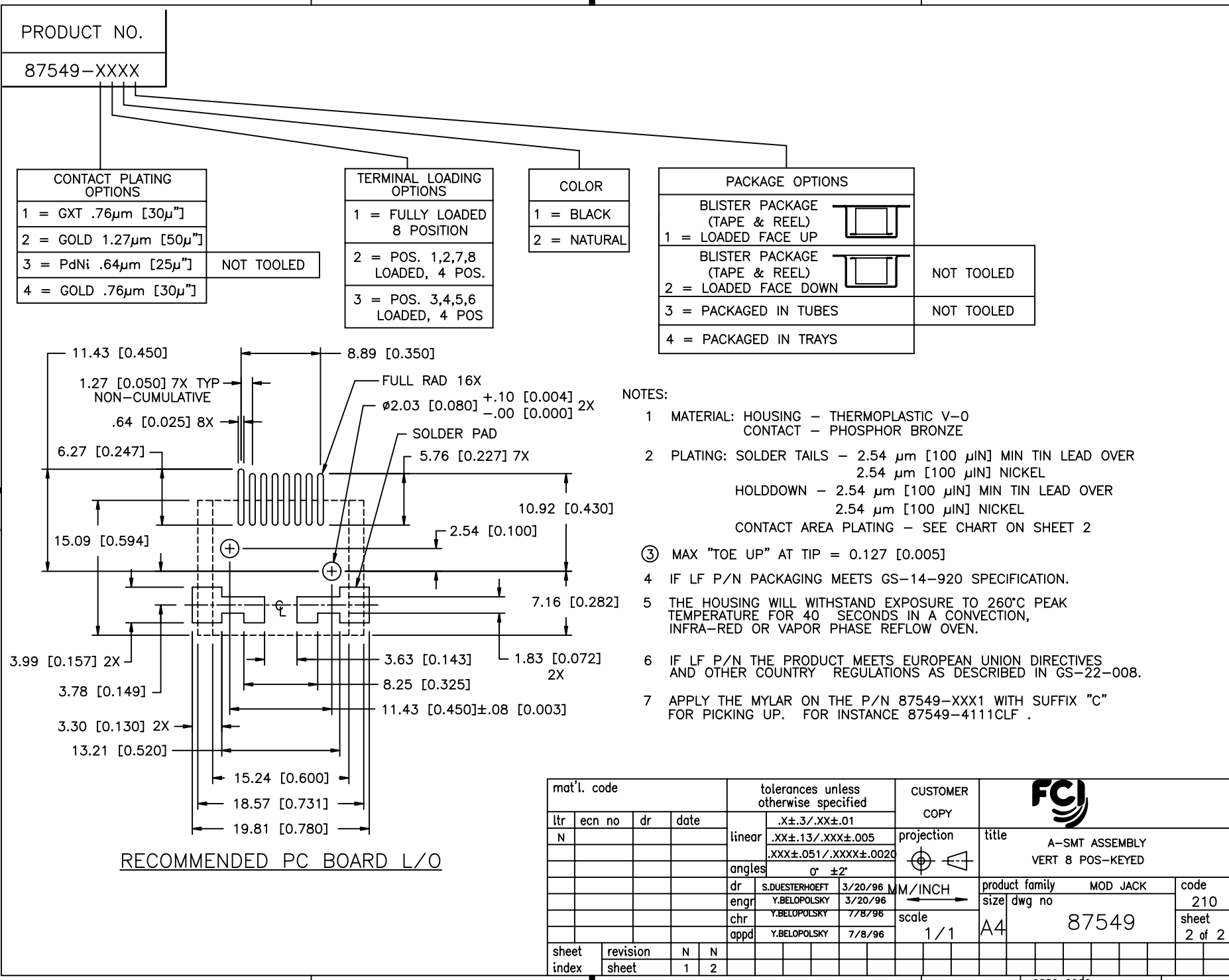

RECOMMENDED PC BOARD L/O

PRODUCT NO.
87549-XXXX

CONTACT PLATING OPTIONS	
1 = GXT .76µm [30µ"]	
2 = GOLD 1.27µm [50µ"]	
3 = PdNi .64µm [25µ"]	NOT TOOLED
4 = GOLD .76µm [30µ"]	

TERMINAL LOADING OPTIONS	
1 = FULLY LOADED 8 POSITION	
2 = POS. 1,2,7,8 LOADED, 4 POS.	
3 = POS. 3,4,5,6 LOADED, 4 POS	

COLOR	
1 = BLACK	
2 = NATURAL	

PACKAGE OPTIONS		
BLISTER PACKAGE (TAPE & REEL)		
1 = LOADED FACE UP		
BLISTER PACKAGE (TAPE & REEL)		NOT TOOLED
2 = LOADED FACE DOWN		
3 = PACKAGED IN TUBES		NOT TOOLED
4 = PACKAGED IN TRAYS		

- NOTES:
- MATERIAL: HOUSING - THERMOPLASTIC V-0
CONTACT - PHOSPHOR BRONZE
 - PLATING: SOLDER TAILS - 2.54 µm [100 µIN] MIN TIN LEAD OVER
2.54 µm [100 µIN] NICKEL
HOLDDOWN - 2.54 µm [100 µIN] MIN TIN LEAD OVER
2.54 µm [100 µIN] NICKEL
CONTACT AREA PLATING - SEE CHART ON SHEET 2
 - MAX "TOE UP" AT TIP = 0.127 [0.005]
 - IF LF P/N PACKAGING MEETS GS-14-920 SPECIFICATION.
 - THE HOUSING WILL WITHSTAND EXPOSURE TO 260°C PEAK TEMPERATURE FOR 40 SECONDS IN A CONVECTION, INFRA-RED OR VAPOR PHASE REFLOW OVEN.
 - IF LF P/N THE PRODUCT MEETS EUROPEAN UNION DIRECTIVES AND OTHER COUNTRY REGULATIONS AS DESCRIBED IN GS-22-008.
 - APPLY THE MYLAR ON THE P/N 87549-XXX1 WITH SUFFIX "C" FOR PICKING UP. FOR INSTANCE 87549-4111CLF.

mat'l. code				tolerances unless otherwise specified		CUSTOMER COPY		FCI	
ltr	ecn no	dr	date	linear	.X±.3/.XX±.01	projection	title		
N					.XX±.13/.XXX±.005		A-SMT ASSEMBLY		
				angles	.XXX±.051/.XXX±.0020		VERT 8 POS-KEYED		
				dr	σ ±2°	M/INCH	product family	MOD JACK	code
				enr	S.DUESTERHOEFT 3/20/96	← →	size	dwg no	210
				chr	Y.BELOPOLSKY 3/20/96	scale	87549		sheet
				appd	Y.BELOPOLSKY 7/8/96	1/1			2 of 2
sheet index	revision sheet	N	N				cage code		
		1	2				STATUS	Released	