

REV.	DATE	ECR NO.	DESCRIPTION
NC	08/18/98	-	INITIAL RELEASE
A	12/03/08	100050	UPDATE DRAWING FORMAT

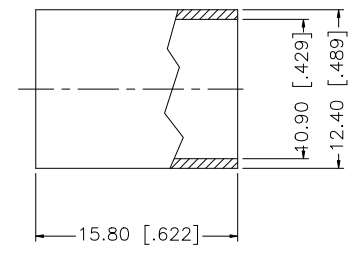
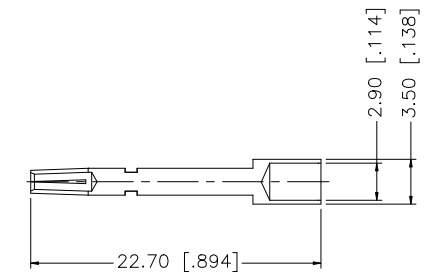
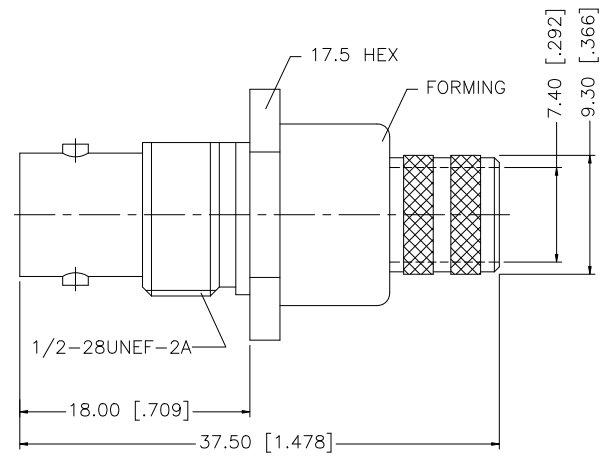
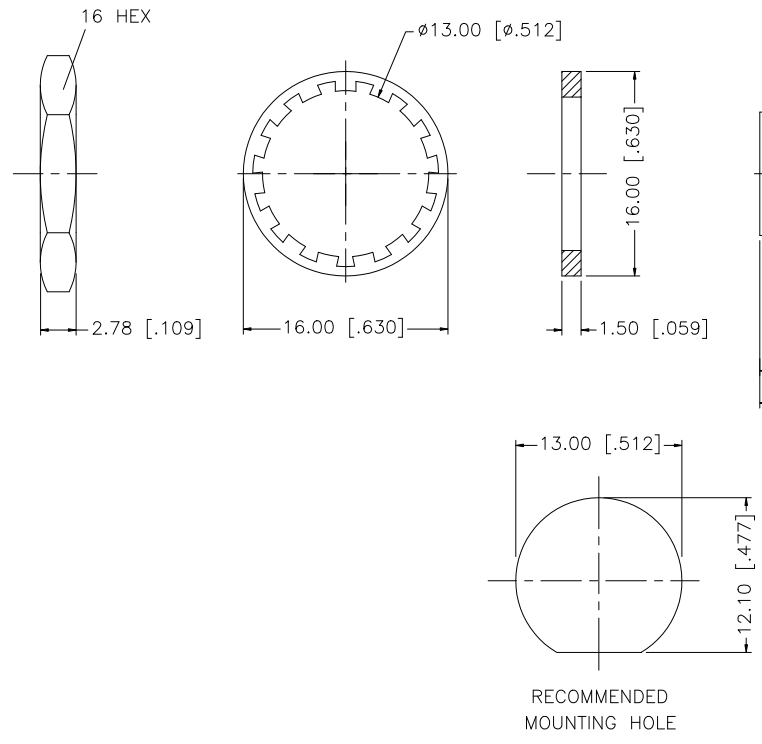
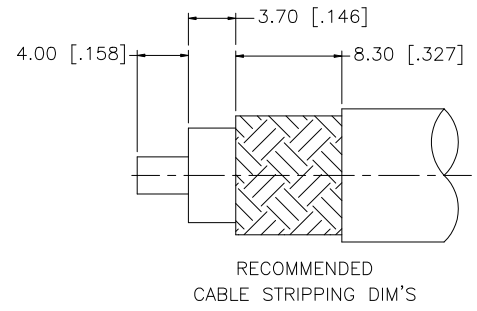

DESCRIPTION	MATERIAL	FINISH	QTY
8			
7	FERRULE	COPPER	NICKEL 1
6	HEX NUT	BRASS	NICKEL 1
5	LOCK WASHER	BRASS	NICKEL 1
4	GASKET	RUBBER	RED 1
3	CONTACT PIN	PHOS. BRONZE	GOLD 1
2	INSULATOR	PTFE	NATURAL 1
1	BODY/HOUSING	BRASS	NICKEL 1

UNLESS OTHERWISE SPECIFIED DIMENSIONS ARE IN MILLIMETERS. DIMENSIONS IN [ ] ARE IN INCHES AND FOR CUSTOMER REFERENCE ONLY.

UNLESS OTHERWISE SPECIFIED TOLERANCES FOR MILLIMETERS ARE:  
0.5 - 8mm ± 0.20mm  
8 - 30mm ± 0.40mm  
30 - 120mm ± 0.50mm

UNLESS OTHERWISE SPECIFIED TOLERANCES FOR INCHES ARE:  
.020 - .315 ± ± 0.007"  
.315 - 1.180 ± ± 0.015"  
1.180 - 4.724 ± ± 0.020"

DO NOT SCALE DRAWING

APPROVALS	DATE
DRAWN GRS	12/03/08
CHECKED	
ISSUED	
SHEET 1 OF 1	
CAD FILE	C:/112/112604.DWG

**Amphenol Connex**

PART DESCRIPTION  
**BNC BULKHEAD CRIMP JACK  
(FOR BELDEN 8214, 9913, 9914 CABLE)**

PART NO.  
**112604**

DWG. NO.	112604.DWG	REV.	A	SIZE	A	SCALE	NA
----------	------------	------	---	------	---	-------	----