

ITEM #	PART #	QTY	DESCRIPTION
1	MAP-50-03	1	WASHER, RUBBER
2	MAP-50-10	1	PLUG INSERT, 7 COND
3	MAP-50-27	1	FIT - SEAL PLUG
4	MAP-50-52	1	OM ADAPTER - $\phi$ .185
5	MAP-50-54	1	7 COND OM PLUG HSG ASSY
6	MAP-57-01	1	STRAIN RELIEF

**B** MAP-57-50

D  
C  
B  
A

D  
C  
B  
A

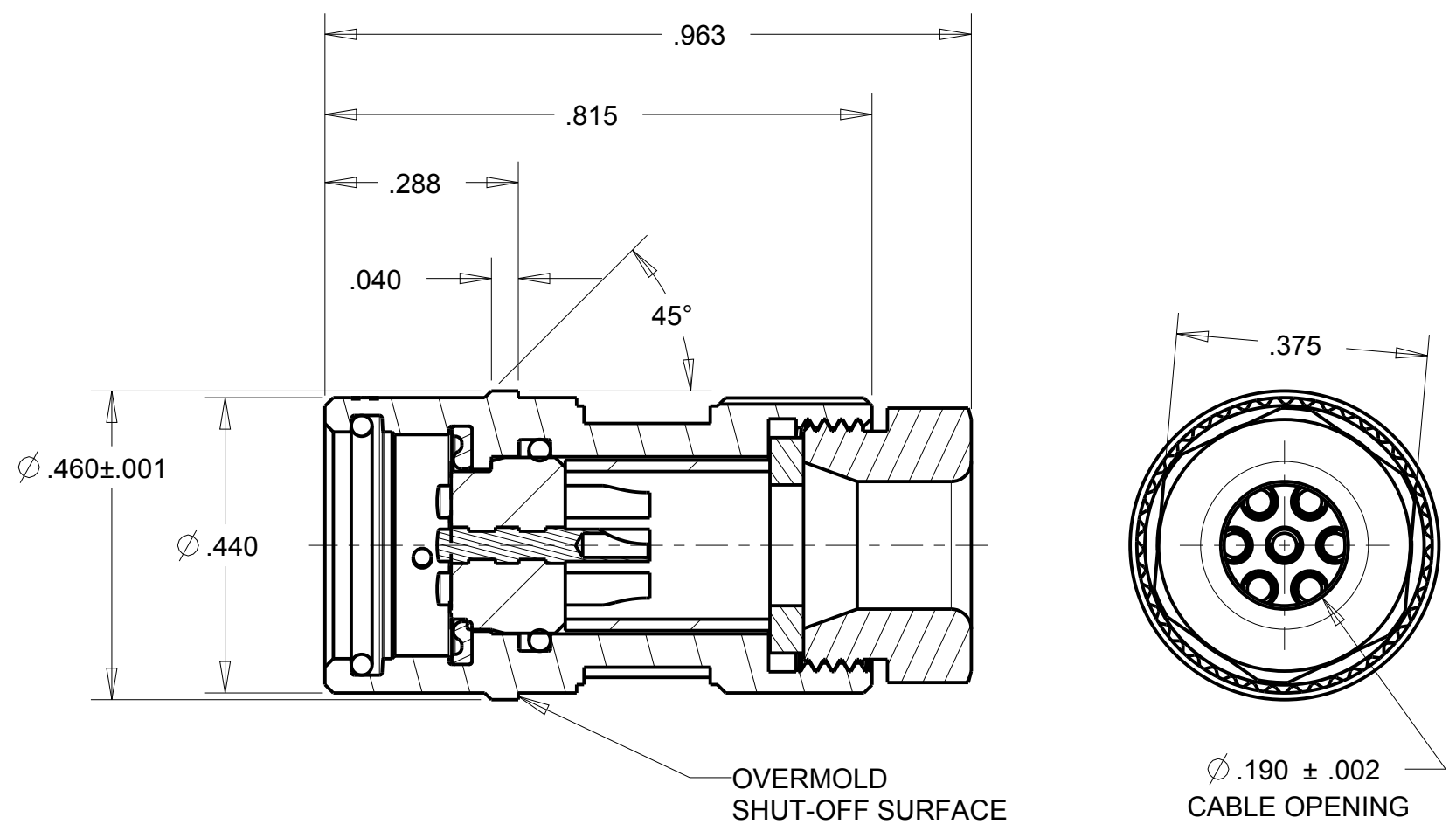
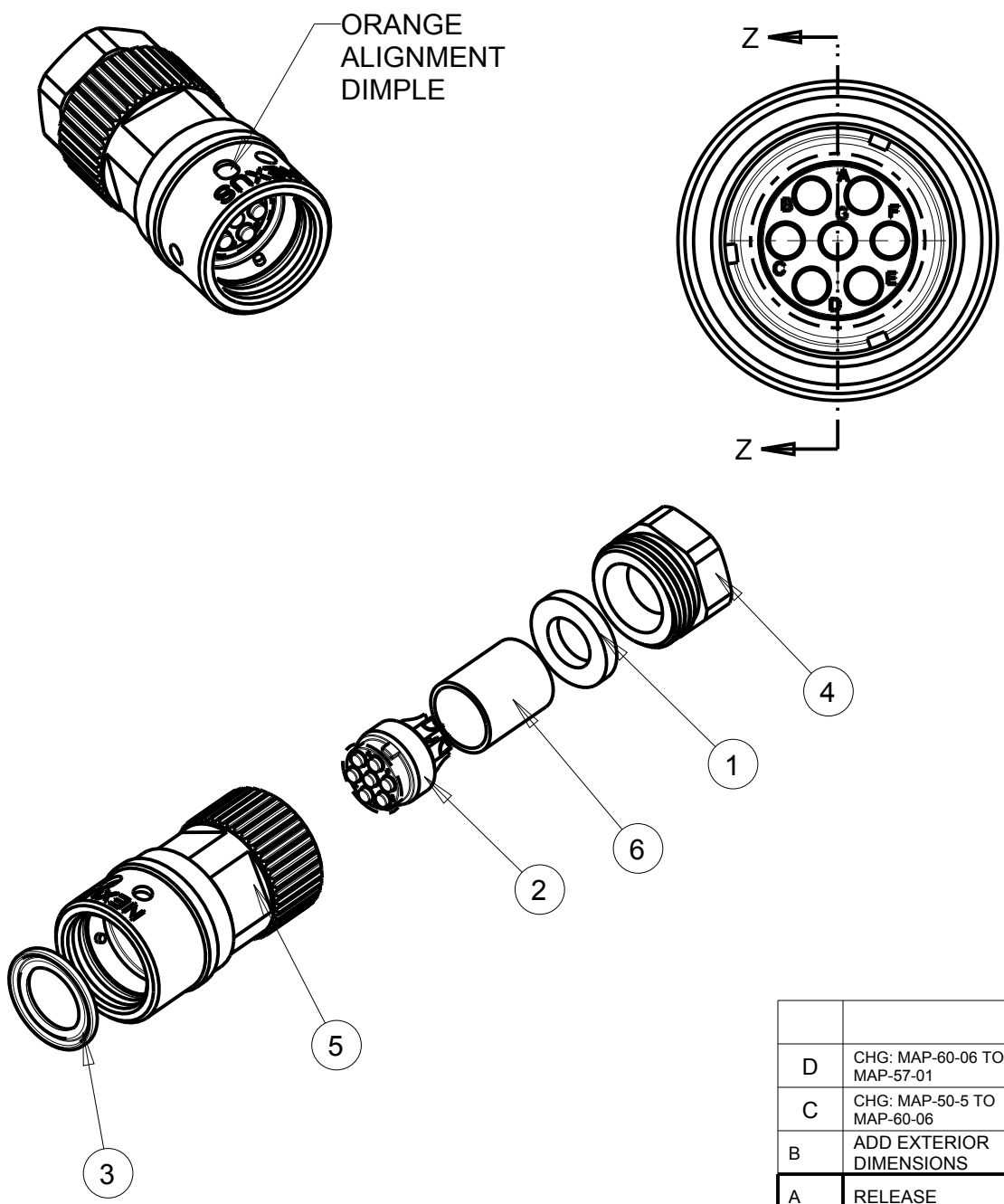

SECTION Z-Z

THIS DOCUMENT CONTAINS PROPRIETARY INFORMATION OF NEXUS, INCORPORATED AND SUCH INFORMATION MAY NOT BE DISCLOSED TO OTHERS FOR ANY PURPOSE OR USED FOR ANY PURPOSE WITHOUT THE WRITTEN CONSENT OF NEXUS.

LET.	REVISION	CN #	DATE	CHK.
D	CHG: MAP-60-06 TO MAP-57-01	152	1/24 2013	HR
C	CHG: MAP-50-5 TO MAP-60-06	146	10/25 2012	HR
B	ADD EXTERIOR DIMENSIONS		07/06 2010	
A	RELEASE		07/01 2010	

DWN.BY	LDE	DATE	01-July-10
CHECKED BY		DATE	
APPR.BY		DATE	
UNLESS OTHERWISE SPECIFIED: DIMENSIONS ARE IN INCHES &/OR [mm]			
TOLERANCES:			
DECIMAL: .XX[X.X] .XXX[X.XX]			
$\pm .01[0.3] \pm .003[0.08]$			
FRACTION: X/X			
$\pm 1/64$			
ANGLES: X			
$\pm .5^\circ$			

MATERIAL	
FINISH	
WEIGHT	SCALE = 4.00 :1
TITLE	
7 COND. OM PLUG-.185" CABLE	
DO NOT SCALE DWG.	SHEET 1 OF 1

**NEXUS**  
STAMFORD, CONN

SIZE **B** DWG. NO. MAP-57-50