

**Nuvoton
300mA Linear Regulator
NCT3703U Series**

-Table of Content-

1. GENERAL DESCRIPTION	1
2. FEATURES	1
3. BLOCK DIAGRAM	2
4. PIN CONFIGURATION AND TYPICAL APPLICATION CIRCUIT	4
5. PIN DESCRIPTION.....	5
6. FUNCTIONAL DESCRIPTION	6
6.1 OUTPUT VOLTAGE AND DROPOUT VOLTAGE	6
6.2 NOISE	6
6.3 PSRR	6
6.4 LOAD REGULATION CONSIDERATION	7
6.5 CURRENT LIMIT PROTECTION	8
6.6 V_{IN} & V_{OUT} CAPACITOR SELECTION	8
6.7 OVER TEMPERATURE PROTECTION.....	8
6.8 LAYOUT NOTE.....	9
6.9 THERMAL CONSIDERATION.....	9
7. ELECTRICAL CHARACTERISTIC	10
7.1 ABSOLUTE MAXIMUM RATINGS	10
7.2 THERMAL INFORMATION	11
7.3 RECOMMENDED OPERATING CONDITIONS.....	11
7.4 ELECTRICAL CHARACTERISTICS.....	11
8. TYPICAL OPERATING WAVEFORMS	13
9. PACKAGE DIMENSION	17
TAPING SPECIFICATION.....	17
10. ORDERING INFORMATION.....	18
11. TOP MARKING SPECIFICATION.....	18
12. REVISION HISTORY	19

1. GENERAL DESCRIPTION

The NCT3703U is a low supply current and low dropout linear regulator which provides 300mA power for battery-powered application such as notebook computers, cellular phones, and handheld devices. An over current protection and an over-temperature protection circuit were built-in the chip to prevent current and thermal overload. Featured low noise, high PSRR and low dropout make it ideal for audio codec and handheld devices. It comes in a space saving SOT-23-5 package and suitable for handheld applications.

The NCT3703U has two versions for different operation circuits. In fixed mode, the SET pin is connected to ground. The output voltage is a preset value. There is no external component required. When an output other than the preset value is needed, two external resistors should be used as an output voltage divider and operates in adjustable mode. The output voltage can be adjusted by the resistor ratio and regulates from 1.25V to 5.0V.

2. FEATURES

2.1. General

- Guaranteed 300mA Output Current
- Low Ground Current 90uA @ No Load (Typical)
- 70dB PSRR @ 10mA, 100Hz
- Low Dropout Voltage 145mV @ 150mA ($V_{OUT} = 5V$)
- Low Output Noise 28u Vrms @ 1mA with Bypass Capacitor
- Excellent Load Regulation & Line Regulation
- Short Circuit Protection & Over Current Protection
- Over Temperature Protection
- Stable with Low ESR Capacitor
- 0°C to 70°C Ambient Operating Temperature Range

2.2. Package

- SOT23-5 Green Package (Lead Free and Halogen Free)

2.3. Application

- Desktop PCs, Notebooks, and Workstations
- Graphics Card or Add-on Card Low Power Applications
- Set Top Boxes, Digital TVs and Printers
- Digital Still Camera and Camcorders
- Mobile or handheld Devices

3. BLOCK DIAGRAM

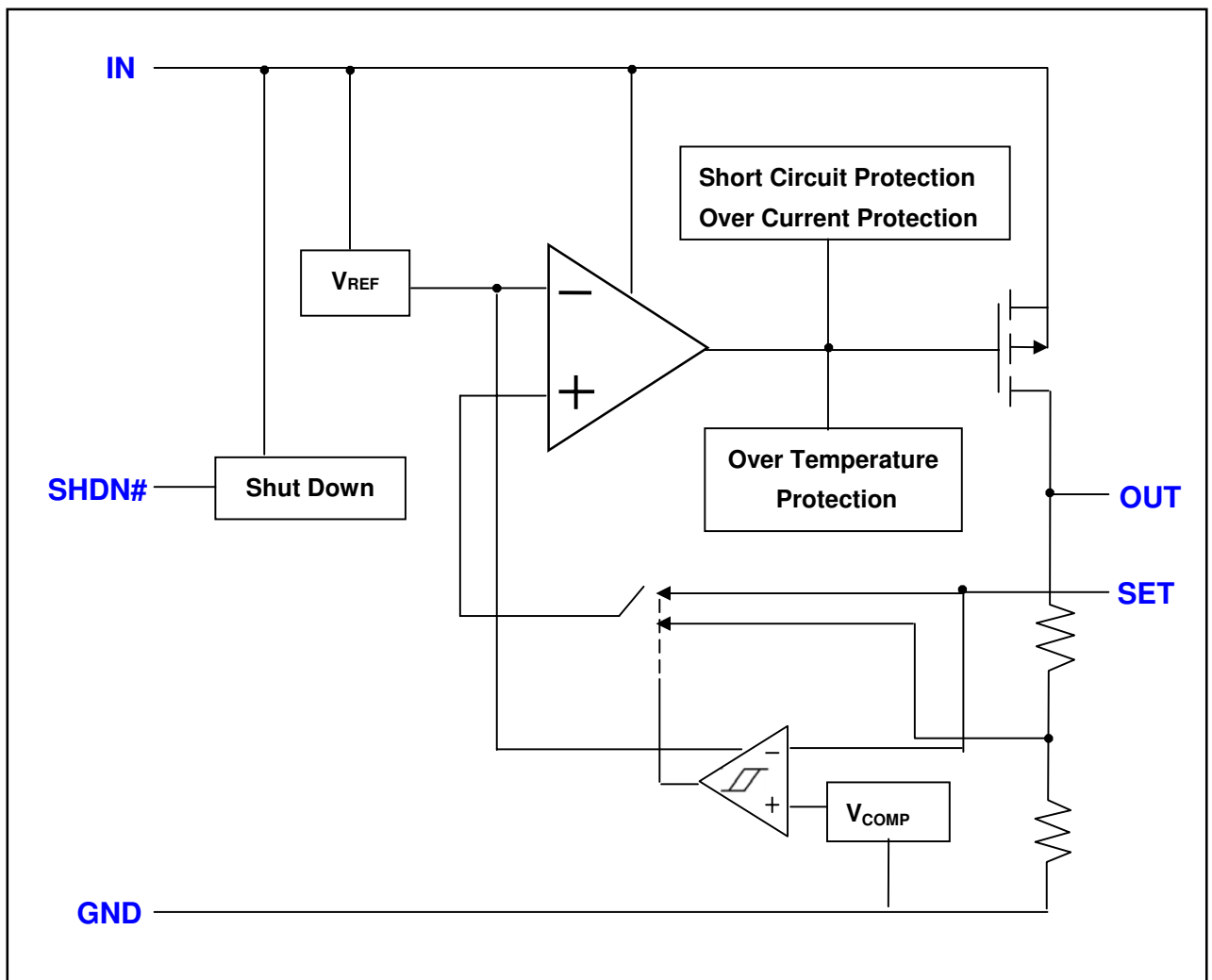

Figure1. Adjustable Mode

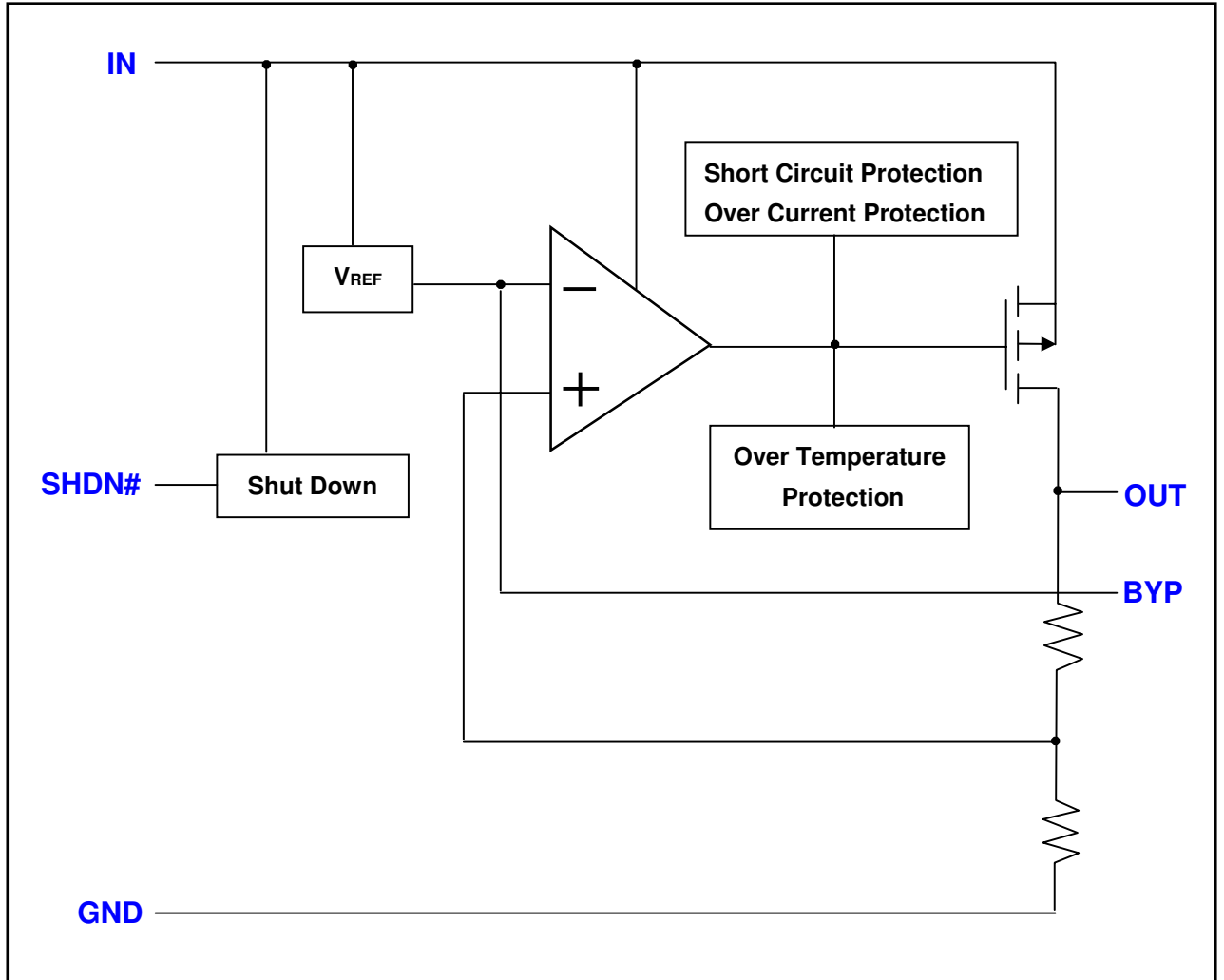

Figure2. Fixed Mode

4. PIN CONFIGURATION AND TYPICAL APPLICATION CIRCUIT

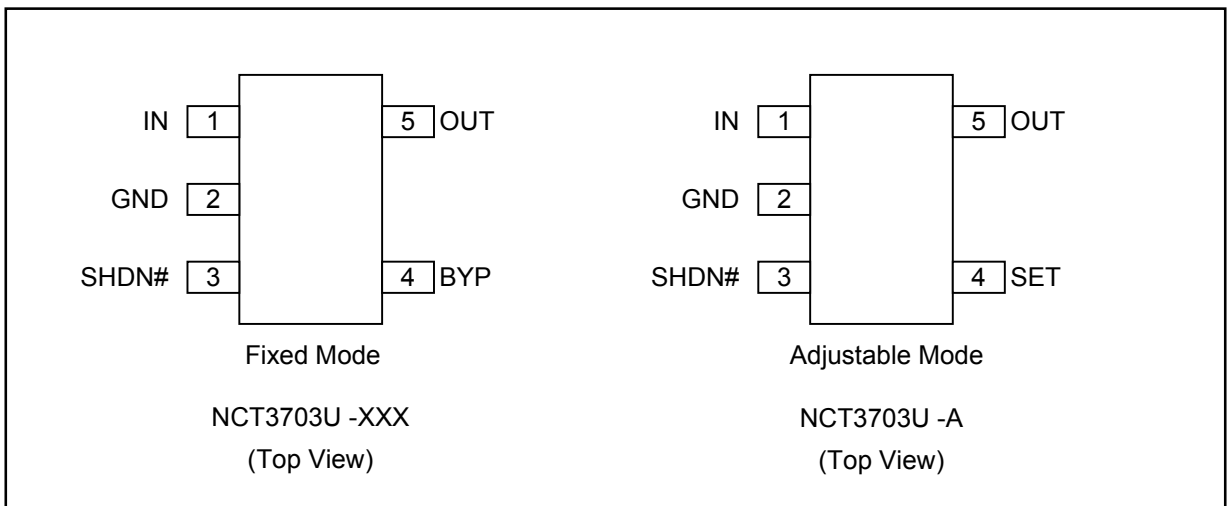

Figure3. Pin Configuration

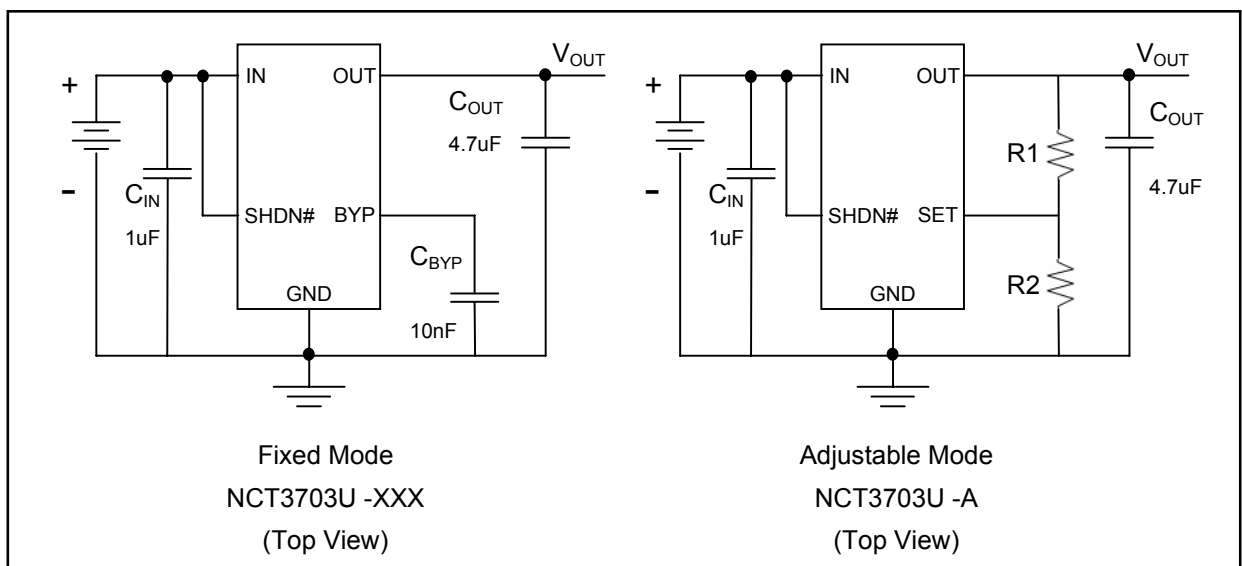

Figure4. Typical Application Circuits

5. PIN DESCRIPTION

NAME	PIN		I/O	FUNCTION
	NCT3703 U-A	NCT3703 U-XXX		
IN	1		I	Regulator input voltage. Supply voltage can range from 2.5V to 6.0V.
GND	2			Ground
SHDN#	3		I	Active-Low shutdown input pin. A logic low reduces the supply current to 1uA. Connect to IN for normal operation.
BYP		4	O	This is a reference bypass pin. It should connect an external capacitor to GND to reduce output noise.
SET	4		I	Feedback input for setting the output voltage. Connect to GND to set the output voltage to the preset output voltage. Connect to an external resistor divider for adjustable-output operation.
OUT	5			Regulator output. Fixed or adjustable from 1.25V to 5.0V with sourcing current which up to 300mA.

6. FUNCTIONAL DESCRIPTION

6.1 Output Voltage and Dropout voltage

The output voltage of NCT3703U-A can be adjusted by the resistive divider between OUT, SET and GND pins. The internal V_{REF} is 1.25V and the output voltage is given by the following equation:

$$V_{OUT} = V_{REF} (1 + R1/R2) = 1.25(1 + R1/R2)$$

For the reasons of reducing power dissipation and loop stability, R2 is chosen to be 120K Ω .

Alternatively, the relationship between R1 and R2 is given by:

$$R1 = R2 (V_{OUT} / 1.25 - 1)$$

A regulator's minimum input-output voltage differential (or dropout voltage) determines the lowest usable supply voltage. NCT3703U uses a P-channel MOSFET pass transistor, its dropout voltage is a function of $R_{DS(ON)}$ multiplied by the load current. Dropout voltage is defined as the input-output voltage differential at which output 100mV below the standard of output voltage. The NCT3703U has a very low dropout voltage 280 mV (typical at $V_{OUT} = 5V$) with 300mA of output current.

6.2 Noise

Noise is specified in two—spot noise or output noise density is the RMS (root means square) sum of all noise source, measured at the regulator output , at a specific frequency from 10Hz~100KHz, this type of frequency. Total output noise or Broad-Band Noise is the RMS sum of spot noise over specified bandwidth, usually several decades of frequencies. Total output noise is measured in μV (rms).

With the 10nF capacitor at the BYP pin can reduce the noise significantly and is required for loop stability. The bandgap is noise source in the NCT3703U LDO that will generates 32 μV_{rms} in the 10HZ to 100KHZ bandwidth. It will be increased following the loop gain as below equation:

$$V_{noise} = 32\mu V_{rms} * (V_{O}/V_{REF}) \mu V$$

6.3 PSRR

PSRR (Power Supply Rejection Ratio) can be improved by C_{BYP} capacitor selection. It's the key of LDO anti-interference capability. With the increasing value of C_{BYP} , the PSRR will be better.

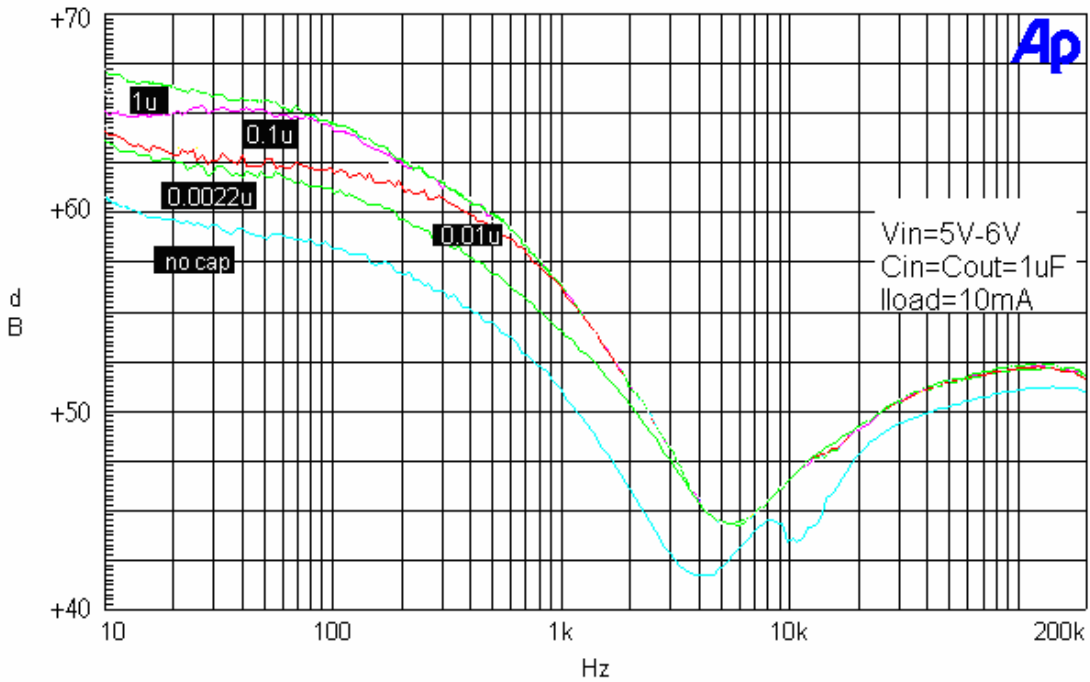

Figure5. Select a C_{BYP} for NCT3703U Circuits

6.4 Load Regulation Consideration

Load regulation will be affected by the length of trace. The impedance of the trace (RLine1 & RLine2) will have influence on the V_{OUT}. The output voltage is given by the following equation:

$$V_{OUT} = V_{OUT} - [I_{Load} * (R_{Line1} + R_{Line2})] \text{ (Figure 6)}$$

The best method/layout is making terminals of V_{OUT} & R1, R2 & GND as close as possible to reduce the trace impedance. It will have the better load regulation of the circuits. (Figure7)

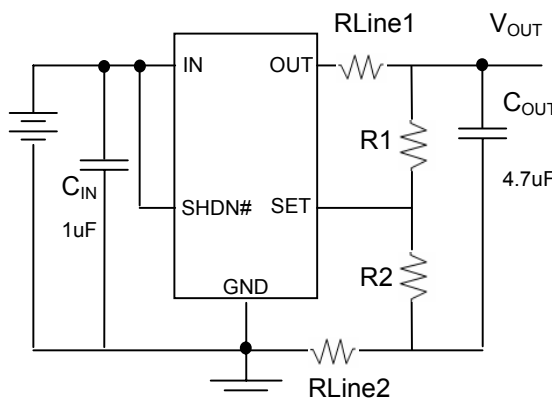

Figure6. Equivalent Trace Impedance Circuits

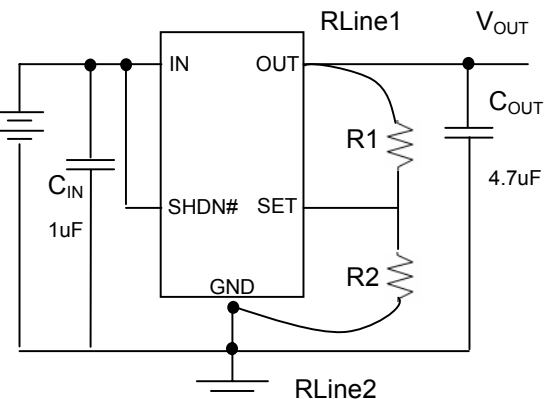

Figure7. Recommended Circuits

6.5 Current Limit Protection

The NCT3703U uses a current sense-resistor to monitor the output current. Once the output current exceeds limit threshold, NCT3703U would be protected with a limited output current. Further more, when the output is short to ground ($<0.7V$), the output current would be folded-back to a less limit and less thermal accumulation.

6.6 V_{IN} & V_{OUT} Capacitor Selection

When operating from batteries, or in applications with long line length (> 10 inches) between the input source and the LDO, some input capacitance is recommended. A minimum of $1.0\mu F$ to $4.7\mu F$ is recommended for most applications.

For applications that have output step load requirements, the input capacitance of the LDO is very important. The input capacitance provides the LDO with a good local low-impedance source to pull the transient currents from in order to respond quickly to the output load step.

For good step response performance, the output capacitor value should be equivalent or higher than the input capacitor. The capacitor should be placed as close to the LDO as possible.

Larger input capacitors will also help reduce any high-frequency noise on the input and output of the LDO and reduce the effects of any inductance that exists between the input source voltage and the input capacitance of the LDO. The recommended value of output capacitor is at least $1\mu F$ with low ESR.

6.7 Over Temperature Protection

The NCT3703U LDO has temperature-sensing circuitry to prevent the junction temperature from exceeding approximately $150^{\circ}C$. If the LDO junction temperature does reach $150^{\circ}C$, the LDO output will be turned off until the junction temperature cools to approximately $110^{\circ}C$, at which point the LDO output will automatically resume normal operation. If the internal power dissipation continues to be excessive, the device will again shut off. The junction temperature of the die is a function of power dissipation, ambient temperature and package thermal resistance.

6.8 Layout note

Dropout and load regulation will be deteriorated when C_{OUT}, C_{IN} and NCT3703U distance is too far. The capacitor must be located a distance of not more than 1 inch from the input and return to a clean analog ground.

By putting C_{BYP} close to the NCT3703U, the transient and PSRR will be improved and performs less output noise.

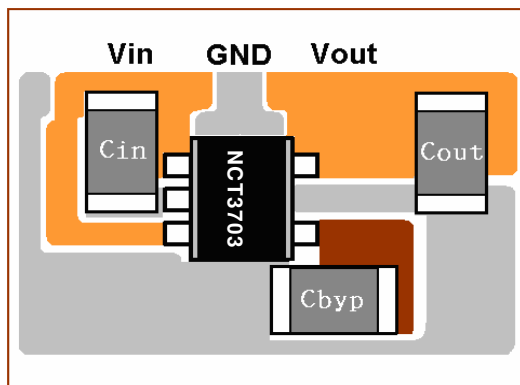

Figure8. Fixed Mode Recommended Layout

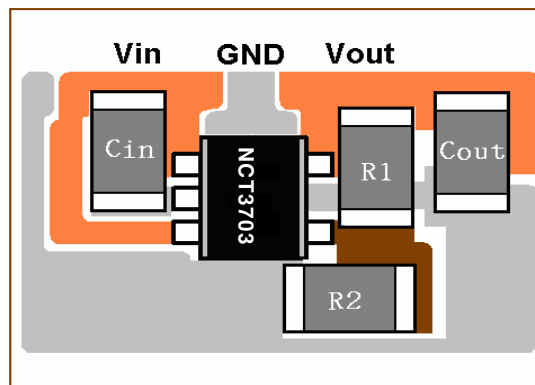

Figure9. Adjustable Mode Recommended Layout

6.9 Thermal Consideration

Different (VIN-VOUT) combinations and ambient temperature play important roles in the thermal dissipation. The maximum power dissipation can be calculated by following formula:

$$P_{D(MAX)} = (T_J - T_A) / \theta_{JA}$$

Where T_J is the maximum junction temperature. T_A is the ambient temperature. θ_{JA} is the junction to ambient thermal resistance.

For example: NCT3703U at the T_A =25°C. it can calculate P_{D(MAX)} = 520mW = (150°C -25°C) / 240°C/W

Differential voltage can to explain below :

$$(V_{IN} - V_{OUT}) = P_{D(MAX)} / I_{OUT}$$

NCT3703U occurs Over Temperature Protection if differential voltage surpasses below Figure10 & Figure11 safe operation range.

Thermal Consideration Area @ Iout=150mA

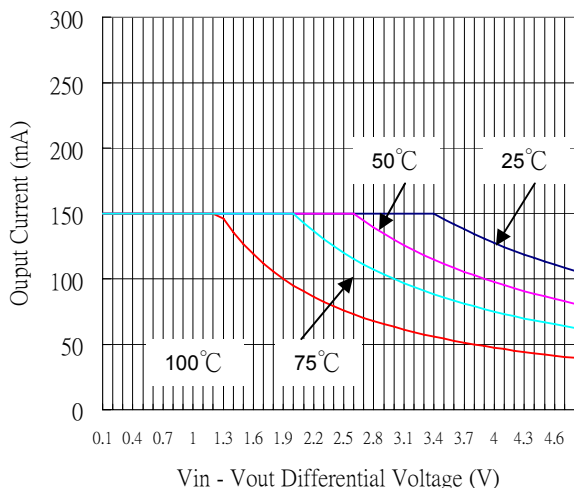

Figure10. Safe Operating Area (IOUT=150mA)

Thermal Consideration Area @ Iout=300mA

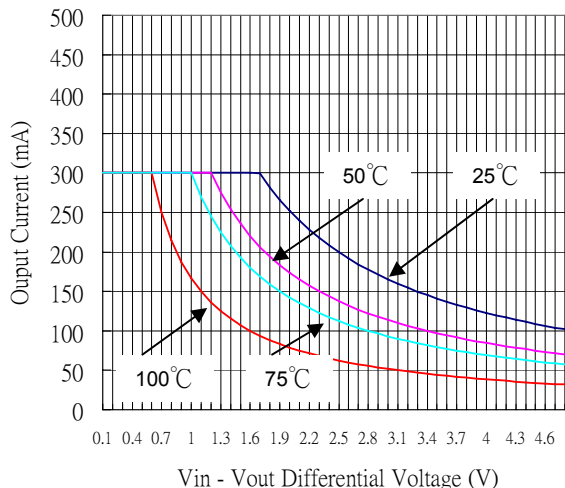

Figure11. Safe Operating Area (IOUT=300mA)

7. ELECTRICAL CHARACTERISTIC

7.1 Absolute Maximum Ratings

ITEM	SYMBOL	RATING	UNIT
Input Voltage	V _{IN}	-0.3 to 7	V
Output Voltage to Ground	V _{OUT}	-0.3 to 7	V
Output Current	I _{OUT}	Internally limited	
Operating Temperature Range	T _{opt}	0 to 70	°C
Electrostatic discharge protection	Human Body Mode	±2	kV
	Machine Mode	±200	V
	Latch-Up	±100	mA

Note: Stresses beyond those listed under "Absolute Maximum Ratings" may cause permanent damage to the device and exposure to absolute maximum rating conditions for extended periods may affect device reliability.

7.2 Thermal Information

ITEM	RATING	UNIT
Power Dissipation, P_D @ $T_A=25^\circ\text{C}$	Internal Limited	W
Package Thermal Resistance, SOT23-5, θ_{JA}	240	$^\circ\text{C/W}$

7.3 Recommended operating conditions

ITEM	SYMBOL	MIN	MAX	UNIT
Input Voltage	V_{IN}	2.5	6.0	V
Continuous Output Current	I_{OUT}	0	300	mA
Peak Output Current	I_{PEAK}	0	500	
Operating Temperature Range		0	70	$^\circ\text{C}$
Junction Temperature Range		0	125	$^\circ\text{C}$

7.4 Electrical Characteristics

PARAMETER	SYMBOL	CONDITION	MIN	TYP	MAX	UNIT	
Input Voltage	V_{IN}		2.5	---	6.0	V	
Output Voltage Accuracy	V_{OUT}	Variation from specified V_{OUT} , $I_{OUT}=1\text{mA}$	-2	---	2	%	
Output Voltage range			1.25	---	5.0	V	
Maximum Output Current			300	---	---	mA	
Current Limit	I_{LIM}		400	550		mA	
Shot Circuit Current	I_{sc}			280		mA	
Ground Pin Current	I_Q		---	90	120	μA	
Dropout Voltage	V_{DROP}	$I_{OUT} = 300\text{mA}$	$V_{OUT} = 1.25\text{V}$	---	1.25	1.8	V
			$V_{OUT} = 1.80\text{V}$	---	0.7	1.2	
			$V_{OUT} = 2.50\text{V}$	---	0.34	0.5	
			$V_{OUT} = 2.80\text{V}$	---	0.31	0.5	
			$V_{OUT} = 3.30\text{V}$	---	0.30	0.5	
			$V_{OUT} = 4.75\text{V}$	---	0.25	0.5	
			$V_{OUT} = 5.00\text{V}$	---	0.24	0.5	
Line Regulation	ΔV_{LNR}	$V_{IN}=V(\text{STD})+0.1\text{V}$ to 6.2V , $I_{OUT}=10\text{mA}$	---	0.05	0.1	%/V	
Load Regulation	ΔV_{LDR}	$I_{OUT}=10\text{mA}$ to 300mA	---	---	0.02	%/mA	
Ripple Rejection	PSRR	Freq. = 100Hz , $I_{OUT}=10\text{mA}$	---	70	---	dB	

Output Voltage Noise (10Hz to 100kHz)	en	C _{OUT} =4.7μF, C _{BYP} =10nF, I _{OUT} =1mA	V _{OUT} =1.25V	---	32	---	μVRMS
			V _{OUT} =3.30V	---	84	---	
			V _{OUT} =4.75V	---	122	---	
			V _{OUT} =5.00V	---	128	---	
Shutdown Supply Current	I _{SHDN}	V _{OUT} =0V, TA=+25°C	---	---	1	μA	
Stable C _{OUT} ESR Range		I _{OUT} =300mA	5m	---	500m	Ω	
SHUTDOWN							
SHDN# Input Threshold	V _{IH}	Regulator enabled	1.5	---	---	V	
	V _{IL}	Regulator shutdown	---	---	0.4		
SHDN# Input Bias Current	I _{SHDN#}	V _{SHDN#} = V _{IN} , TA=+25°C	---	---	0.1	μA	
	I _{QSHDN#}	V _{SHDN#} = GND, TA=+25°C	---	---	0.1		
SET INPUT							
SET Reference Voltage	V _{SET}	V _{IN} =2.5V to 5.5V , I _{OUT} =1mA	TA=+25°C	1.225	1.25	1.275	V
			TA=T _{MIN} to T _{MAX}	---	1.25	---	
SET Input Leakage current	I _{SET}	V _{SET} = 1.3V	TA=+25°C	---	5	30	nA
THERMAL PROTECTION							
Thermal Shutdown Temperature	T _{SHDN}		---	150	---	°C	
Thermal Shutdown Hysteresis	ΔT _{SHDN}		---	40	----	°C	

8. TYPICAL OPERATING WAVEFORMS ($V_{OUT}=4.75V$)

Turn – on time

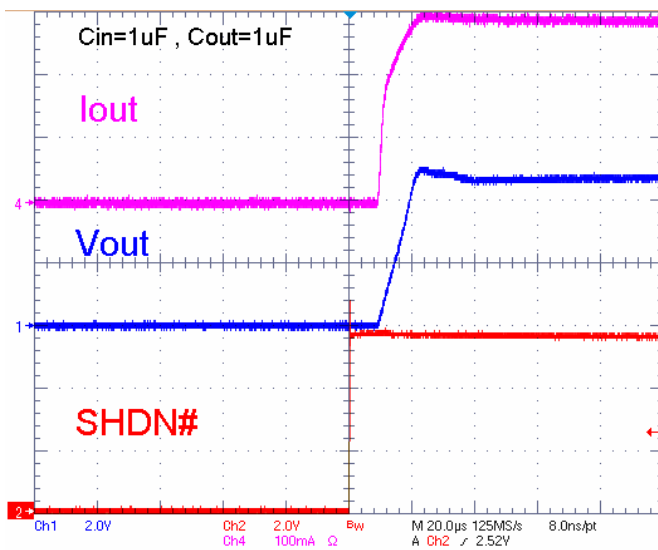

Turn – off time

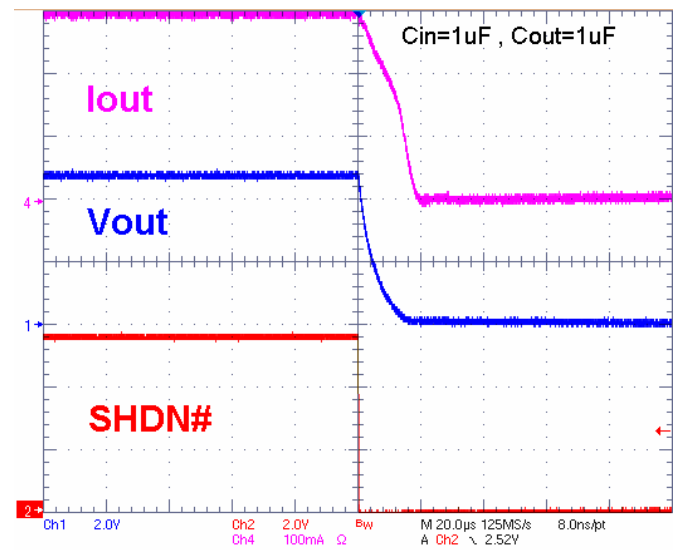

Line Transient

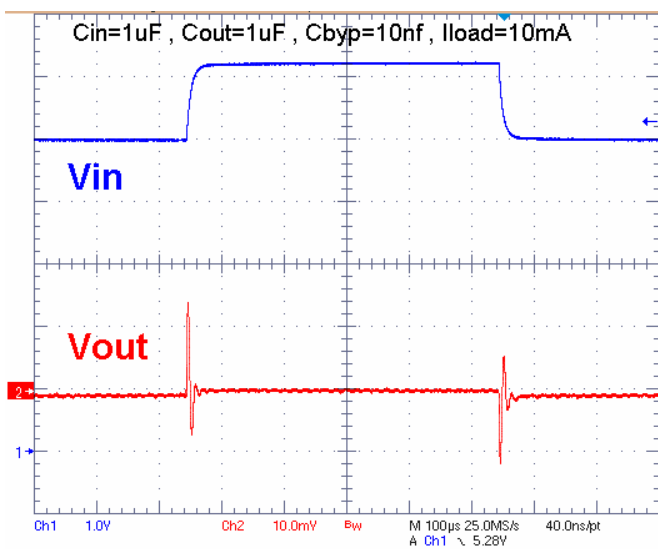

Load Transient

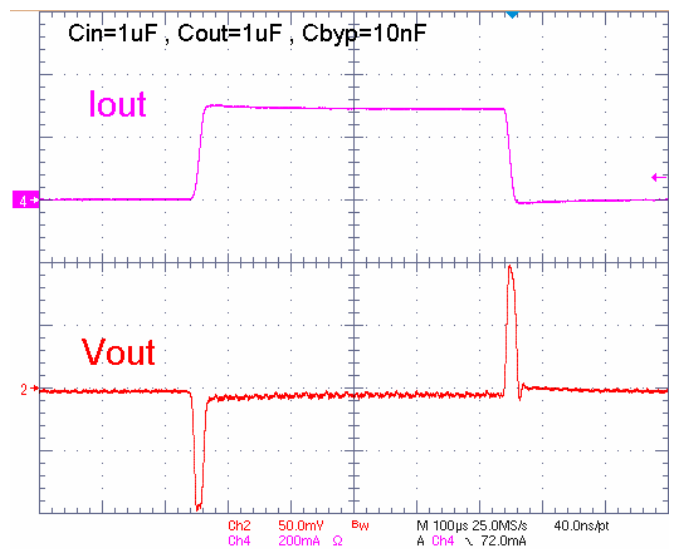

Short Circuit Protection

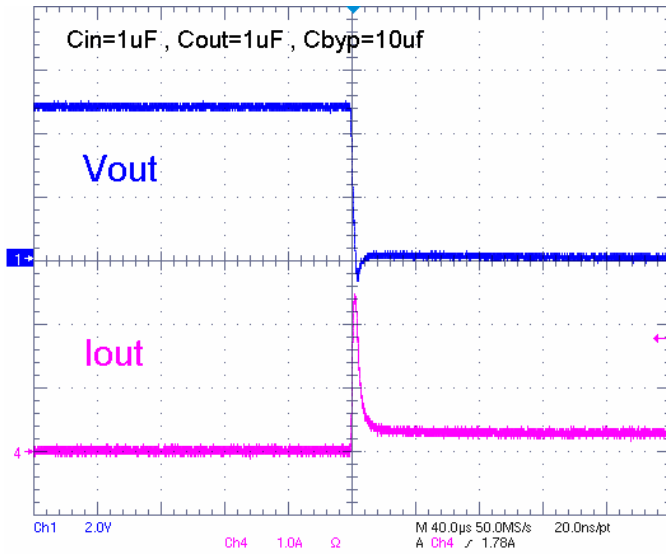

Over Current Protection

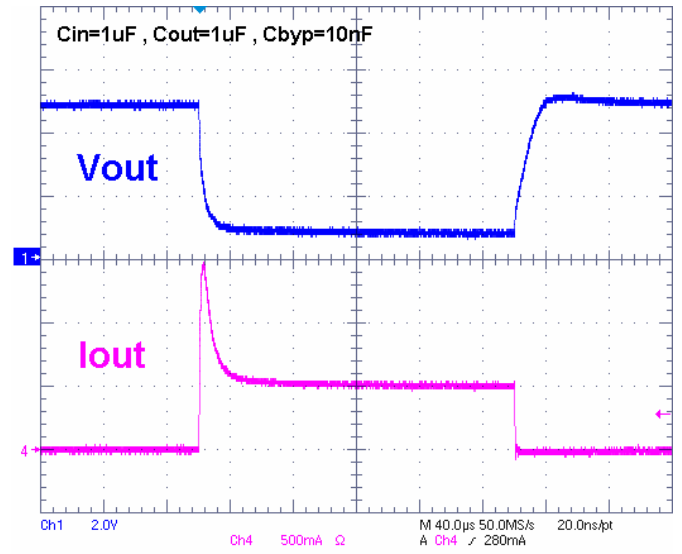

Power Supply Rejection Ratio

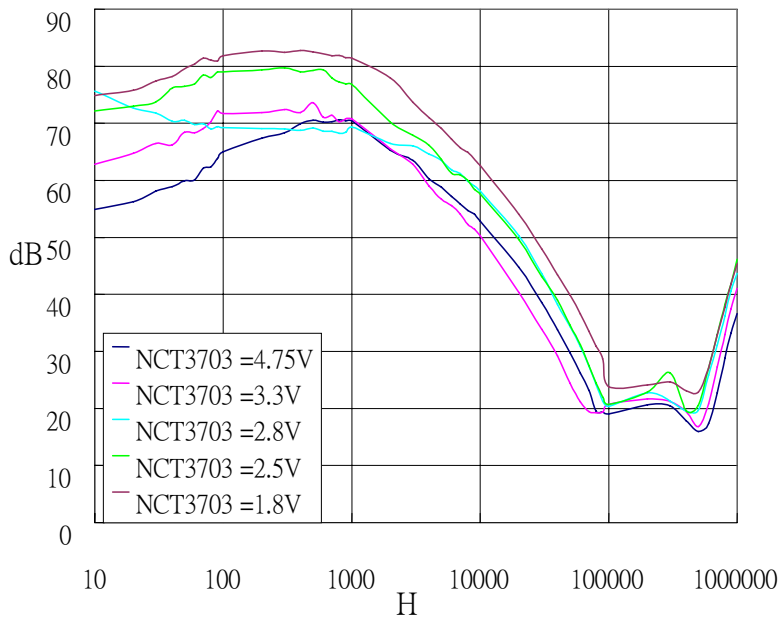

Output Voltage Noise

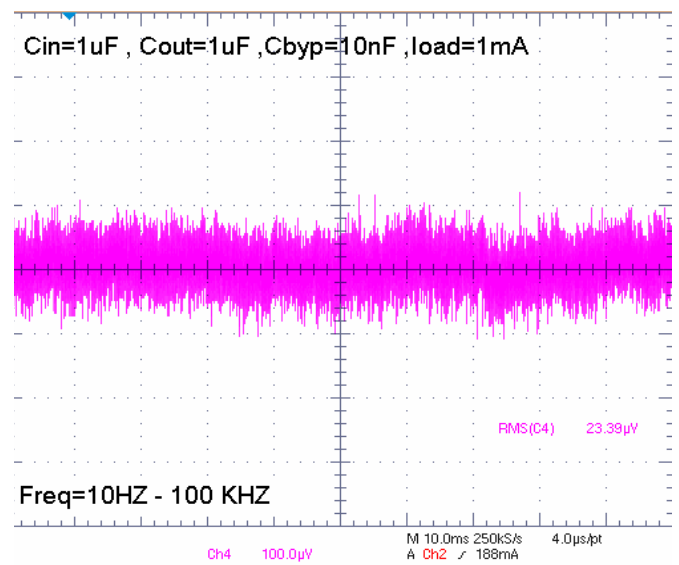

Dropout voltage VS Output Current

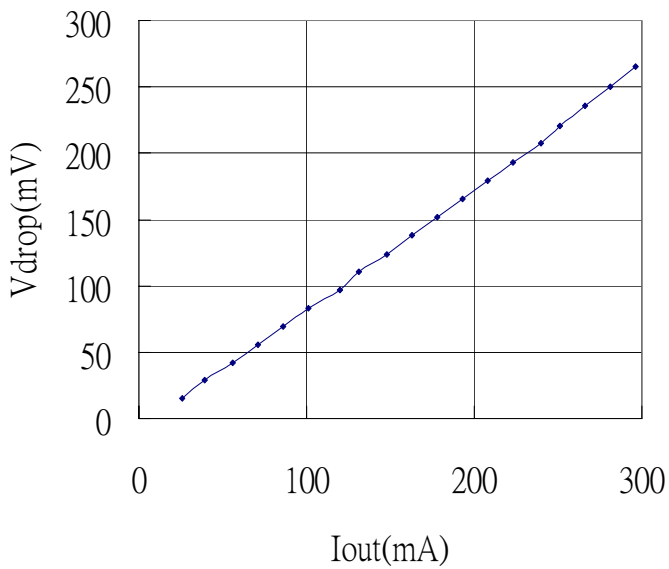

Quiescent current VS Output Current

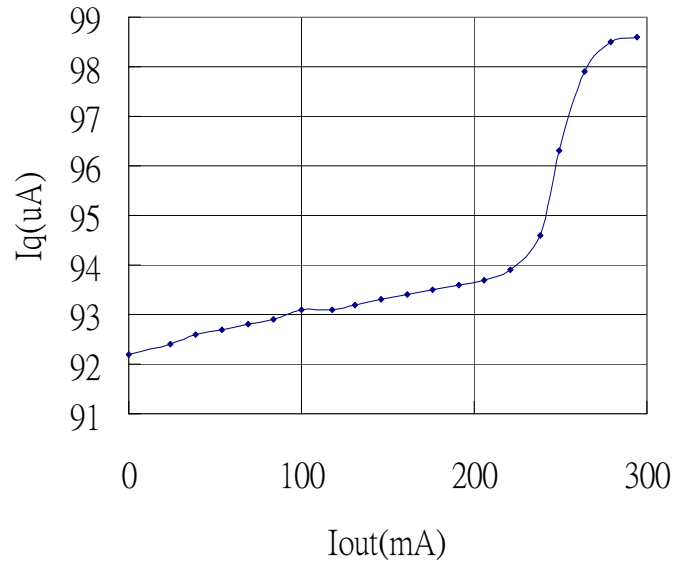

Line Regulation VS Output Current

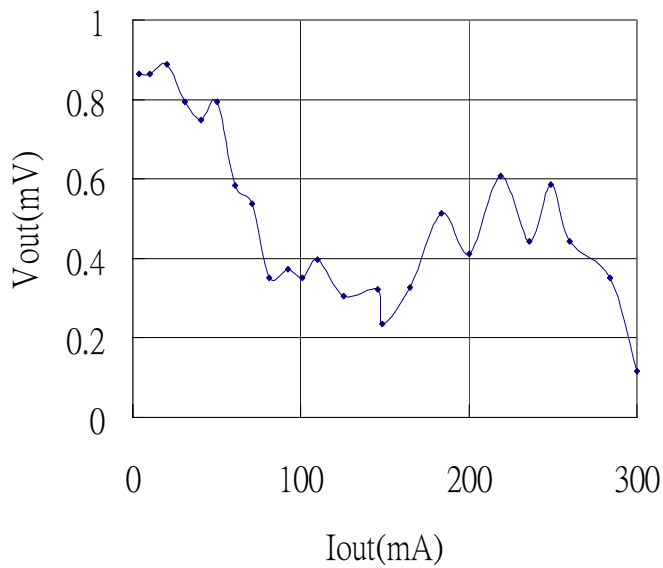

PSRR VS Output Current

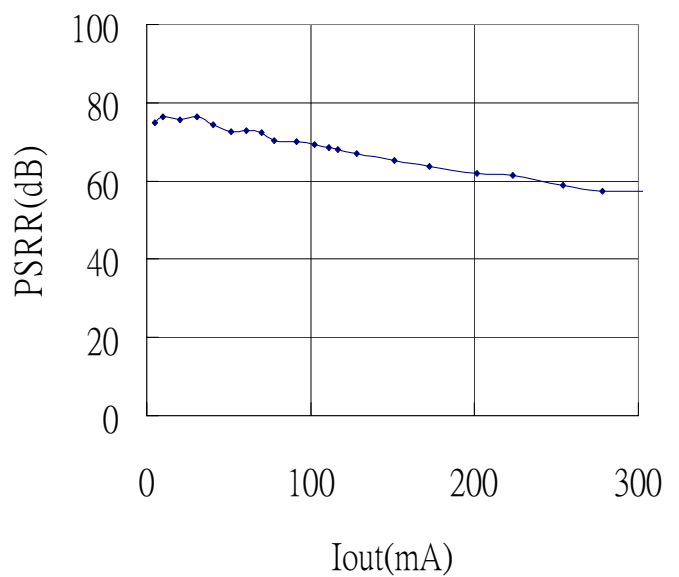

Dropout VS Temperature

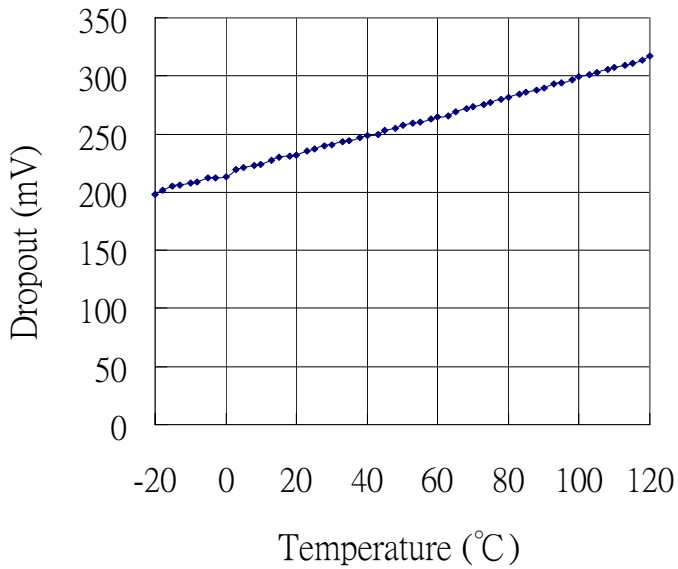

Output Voltage VS Temperature

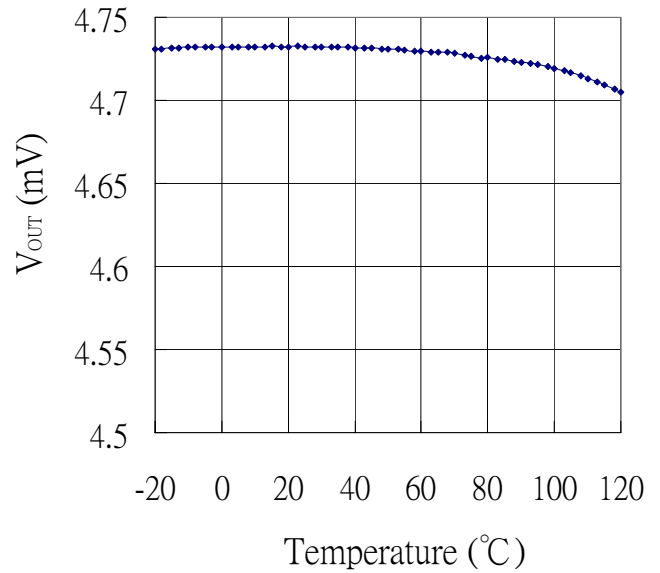

Quiescent Current VS Temperature

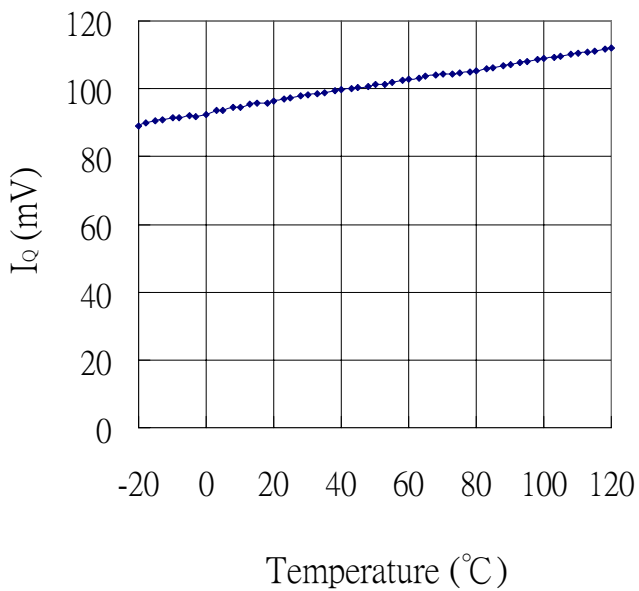

P.S.R.R VS Temperature

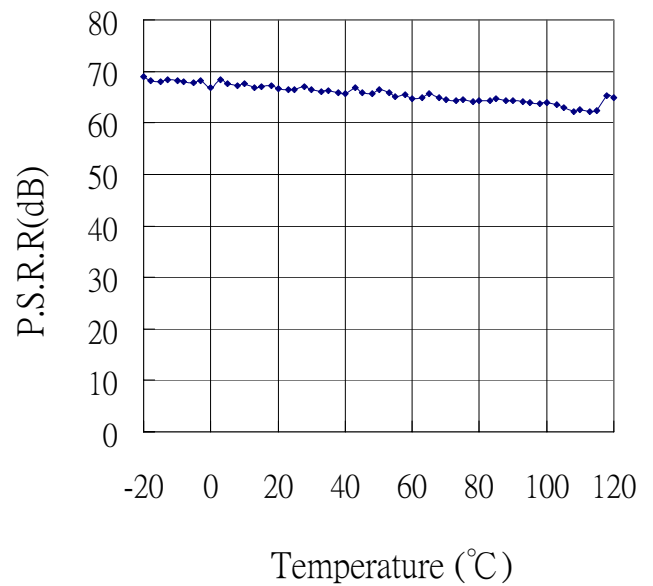

9. PACKAGE DIMENSION

5pin SOT23 Package

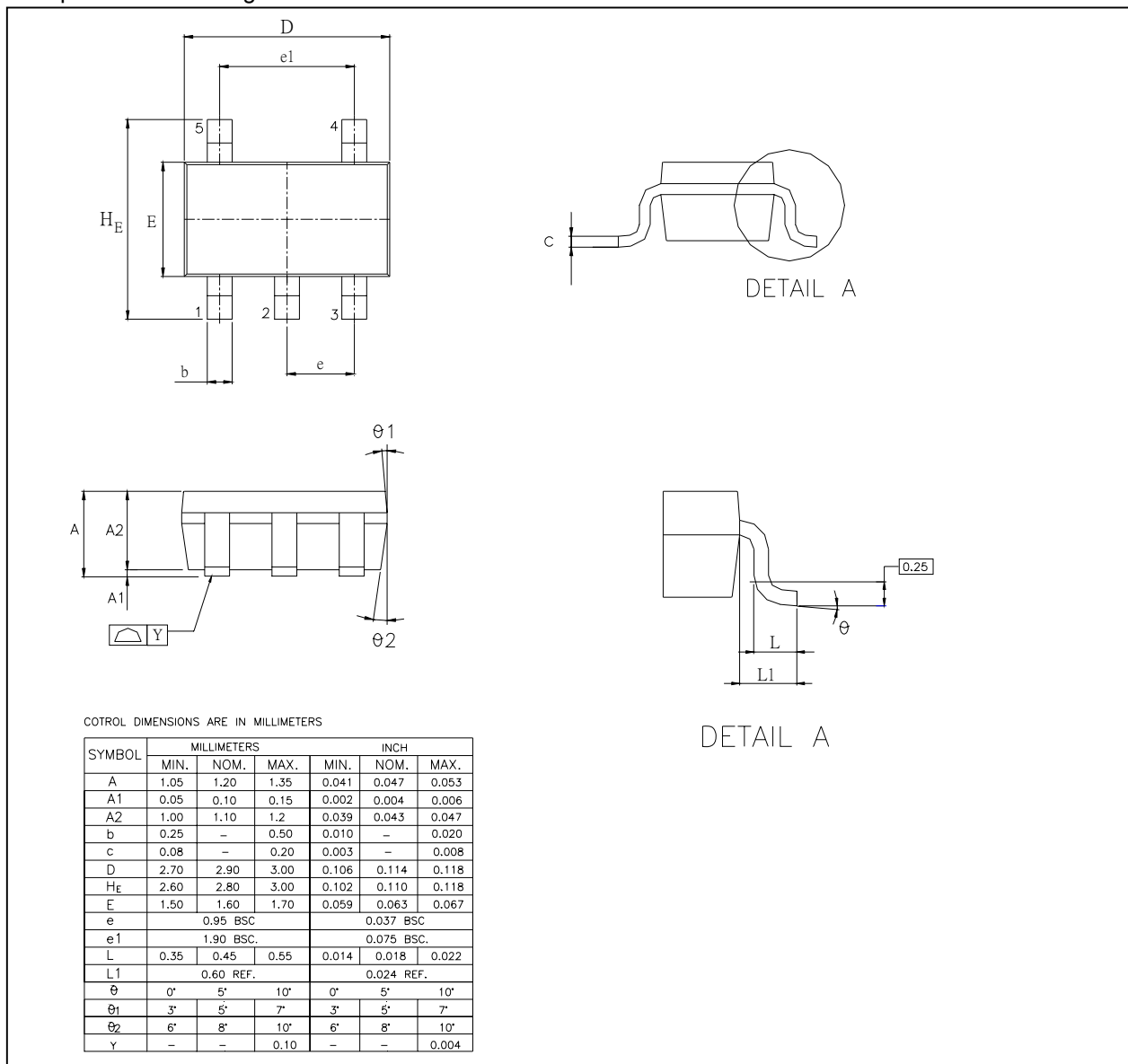

➤ TAPING SPECIFICATION

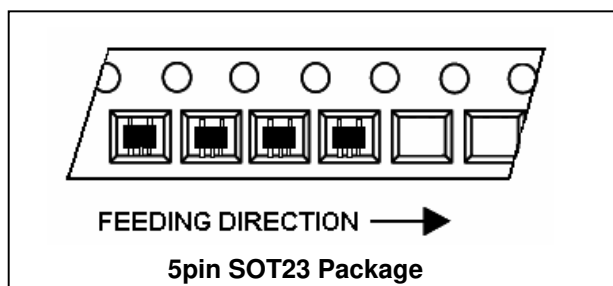

10. ORDERING INFORMATION

PART NUMBER	MARKING	V _{OUT}	SUPPLIED AS	PACKAGE TYPE	PRODUCTION FLOW
NCT3703U-A	3A00	ADJ	T Shape: 3,000 units/T&R	5 PIN SOT23 (Green package)	Commercial, 0°C to +70°C
NCT3703U-12	3120	1.2V			
NCT3703U-15	3150	1.5V			
NCT3703U-18	3180	1.8V			
NCT3703U-25	3250	2.5V			
NCT3703U-28	3250	2.8V			
NCT3703U-33	3330	3.3V			
NCT3703U-475	3475	4.75V			
NCT3703U-50	3500	5.0V			

11. TOP MARKING SPECIFICATION

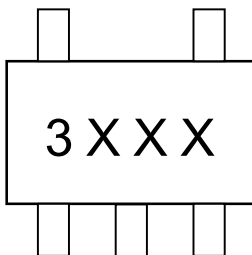

1st Line: 3XXX

- 3: 300mA (NCT3703U)
- XXX : Please check ordering information

12. REVISION HISTORY

VERSION	DATE	PAGE	DESCRIPTION
A1	11/28/2008	All	New Create

Important Notice

Nuvoton products are not designed, intended, authorized or warranted for use as components in systems or equipment intended for surgical implantation, atomic energy control instruments, airplane or spaceship instruments, transportation instruments, traffic signal instruments, combustion control instruments, or for other applications intended to support or sustain life. Further more, Nuvoton products are not intended for applications wherein failure of Nuvoton products could result or lead to a situation wherein personal injury, death or severe property or environmental damage could occur.

Nuvoton customers using or selling these products for use in such applications do so at their own risk and agree to fully indemnify Nuvoton for any damages resulting from such improper use or sales.

Please note that all data and specifications are subject to change without notice.
All the trademarks of products and companies mentioned in this datasheet belong to their respective owners.