

THIS DRAWING IS UNPUBLISHED. RELEASED FOR PUBLICATION
 © COPYRIGHT - By - ALL RIGHTS RESERVED.

REVISIONS				
P	LTR	DESCRIPTION	DATE	APVD
E		FREE STATE DIMENSION UPDATED	01JUL2019	MB

- 1 CONTINUOUS STRIP ON REELS WITH TERMINALS LOCATED ON 10.41±0.08[.410±.003] CENTERS.
- 2 SLOT ACCEPTS 0.57-0.68mm [#23-#21.5] AWG COPPER MAGNET WIRE. 2 WIRES OF THE SAME SIZE MAX PER SLOT.
- 3 CONTACT LEAF ACCEPTS 0.81[.032] THICK POKE-IN TAB, (REFERENCE TAB DRAWING 1217324-1).
- 4 TIN PLATE OVER NICKEL UNDERPLATE.
- 5 TIN PLATE.

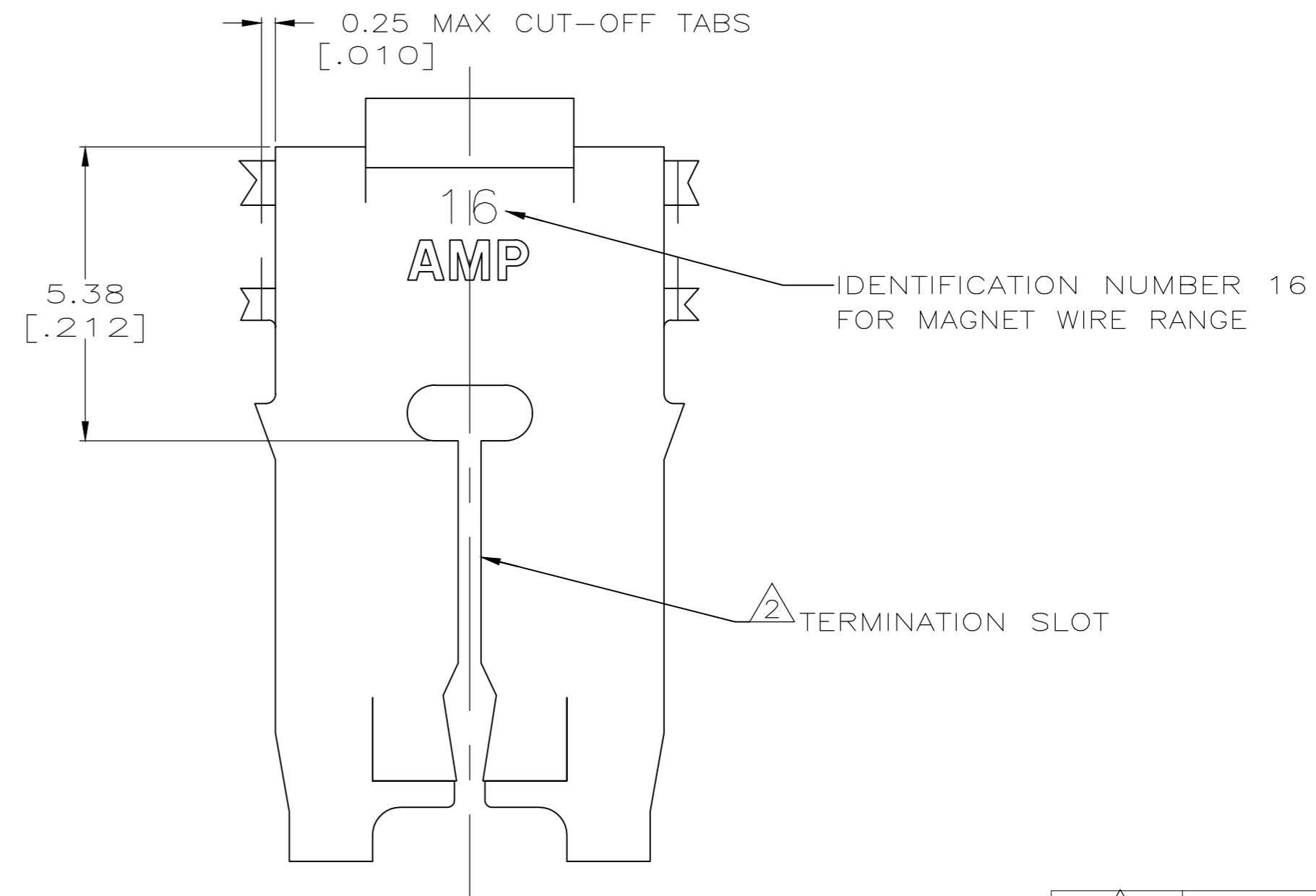
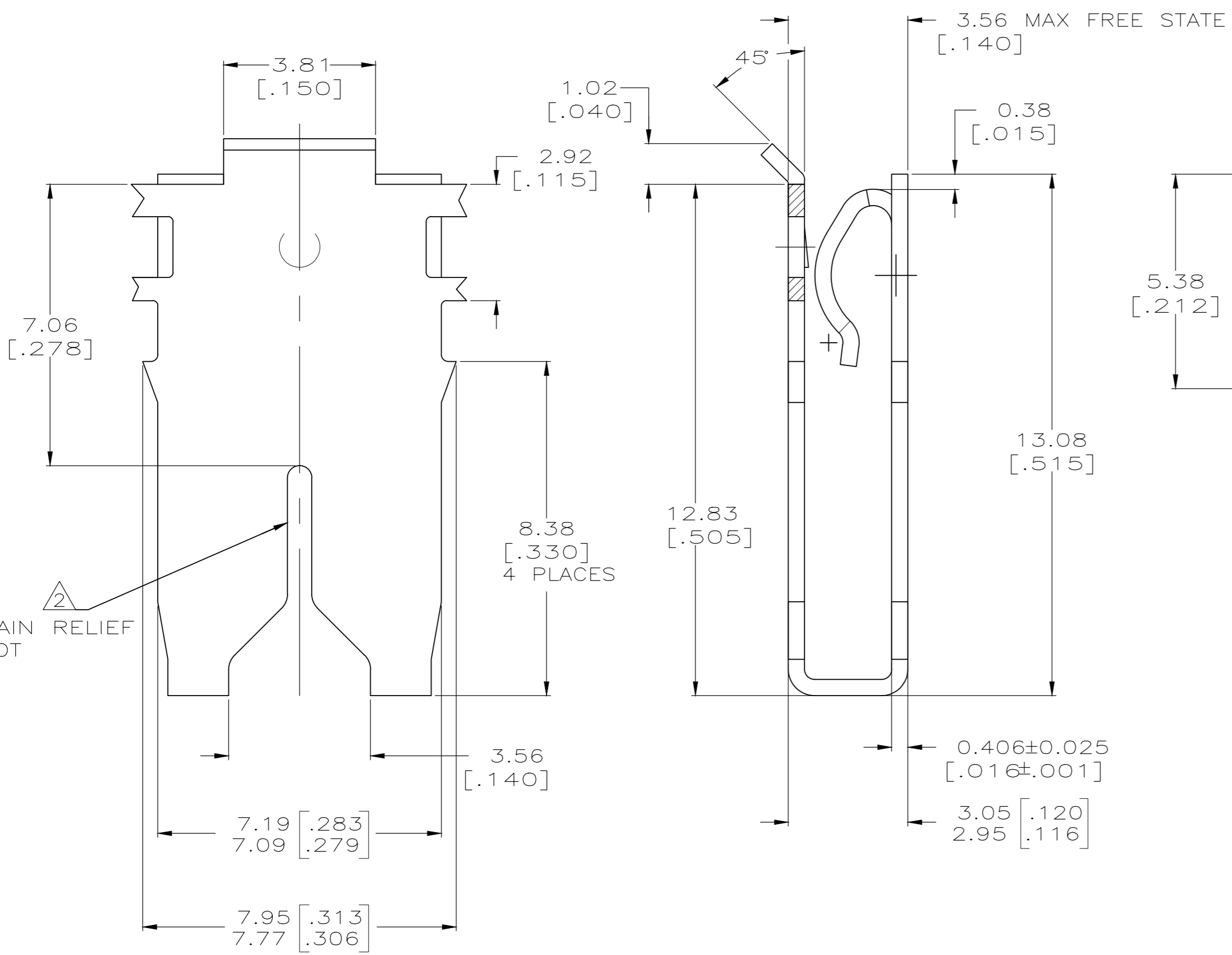
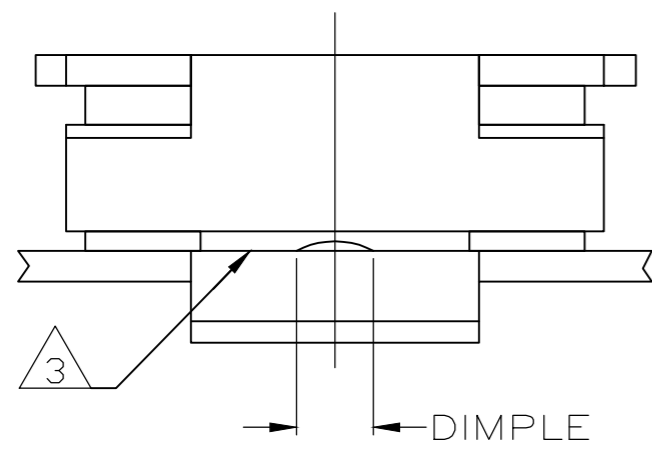

5	1217358-2
4	1217358-1
FINISH	PART NUMBER

THIS DRAWING IS A CONTROLLED DOCUMENT.		DWN MICHAEL S. FEHER 12FEB2007	TE Connectivity	
DIMENSIONS: mm [INCHES]		CHK KURT A. RANDOLPH 12FEB2007		
TOLERANCES UNLESS OTHERWISE SPECIFIED:		APVD KURT A. RANDOLPH 12FEB2007	NAME SPECIAL LEAF CONTACT, 500 SERIES MAG-MATE	
0 PLC ± -		PRODUCT SPEC 108-2053	SIZE A2	
1 PLC ± -		APPLICATION SPEC 114-2066	CAGE CODE 00779	DRAWING NO C=1217358
2 PLC ± 0.25[.010]		MATERIAL BRASS	SCALE 10:1	SHEET 1 of 1
3 PLC ± -		FINISH -	CUSTOMER DRAWING	REV E
4 PLC ± -				
ANGLES ± -				