

Description

The DIODES™ AL17051 is a universal AC high voltage input step down converter that provides accurate 3.3V or 5V output and outstanding dynamic performance and load regulation without requiring an optocoupler over line and load regulation. Typical applications are power supplies for offline low power IoT (Internet of Things) devices that support WPAN (Wireless Personal Area Network) connectivity.

To support Always-On requirements of IoT connectivity, the AL17051 features ultra-low standby operation power of 10mW. It also features high conversion efficiency 60% from rectified mains voltage to 3.3V or 5V for 50mA output and 50% at 10mA light loading during IoT system in idle and sleep mode.

With high-degree integration of the embedded 700V High-Voltage MOS switches, the AL17051 is designed to reduce external components and minimize e-BOM (Bill-Of-Material) with small form factor package and PCB space.

The AL17051 has rich protection features to enhance the system safety and reliability. It has Over Temperature Protection, V_{CC} Under Voltage Lock Out function, Over Current Protection, and Over Load Protection.

The AL17051 is available in the SOT25 package.

Features

- Integrated MOSFET up to 700V
- Fixed Option for Output 3.3V and 5V
- No Load Operation Power Less than 10mW
- High Efficiency 60% at 50mA Output
- High Light-Load Efficiency 50% at 10mA Output
- Universal 85 to 300V_{AC} Input Range
- Supports Low Component-Count Buck Topologies
- Auto-Restart for Over Current and Over Load Faults
- Excellent Load and Line Regulation
- Fast Transient Response
- Constant Voltage (CV) Control
- Under Voltage Lock Out (UVLO) Protection for Input Voltage
- Over Current Protection
- Over Load Protection
- Over Temperature Protection (OTP)
- **Totally Lead-Free & Fully RoHS Compliant (Notes 1 & 2)**
- **Halogen and Antimony Free. “Green” Device (Note 3)**
- **For automotive applications requiring specific change control (i.e. parts qualified to AEC-Q100/101/104/200, PPAP capable, and manufactured in IATF 16949 certified facilities), please [contact us](#) or your local Diodes representative. <https://www.diodes.com/quality/product-definitions/>**

Notes: 1. No purposely added lead. Fully EU Directive 2002/95/EC (RoHS), 2011/65/EU (RoHS 2) & 2015/863/EU (RoHS 3) compliant.
 2. See <https://www.diodes.com/quality/lead-free/> for more information about Diodes Incorporated's definitions of Halogen- and Antimony-free, "Green" and Lead-free.
 3. Halogen- and Antimony-free "Green" products are defined as those which contain <900ppm bromine, <900ppm chlorine (<1500ppm total Br + Cl) and <1000ppm antimony compounds.

Pin Assignments

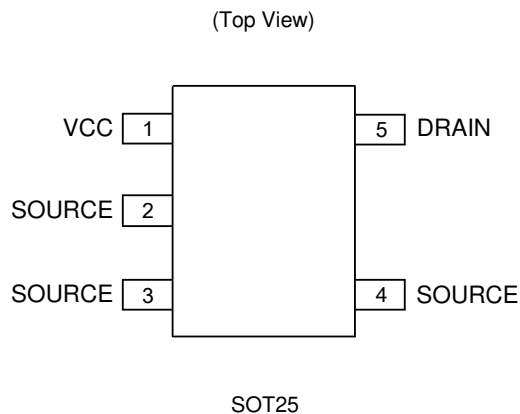

Applications

- Home appliance applications
- IoT applications
- Industrial controls
- Low standby power applications

Typical Application Circuit

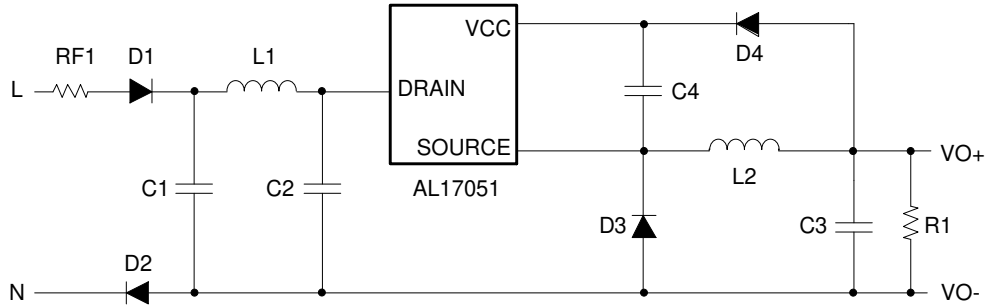
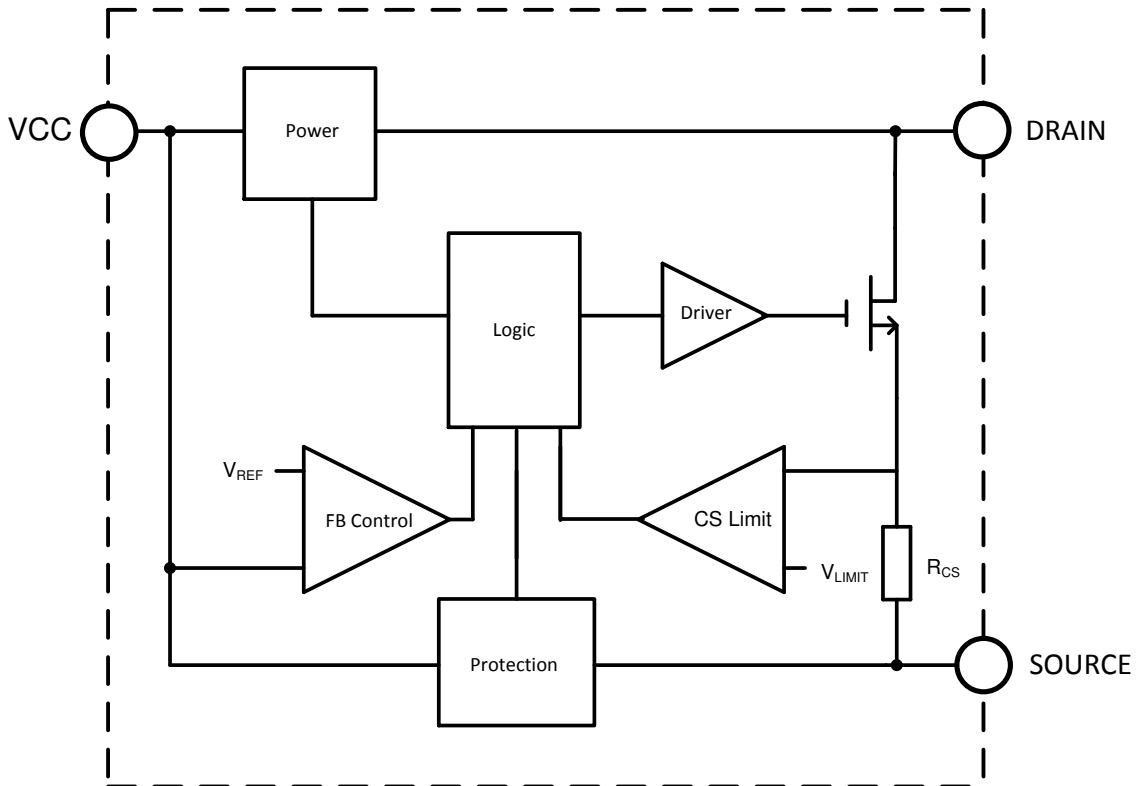

Figure 1 Typical Application Circuit for 3.3V or 5V Output

Pin Descriptions

Pin Number	Pin Name	Function
1	VCC	Control Circuit Power Supply.
2, 3, 4	SOURCE	Internal Power MOSFET Source. Ground reference for device.
5	DRAIN	Internal Power MOSFET Drain. High voltage current source input.

Functional Block Diagram



Absolute Maximum Ratings (Note 4)

Symbol	Parameter	Rating	Unit
V _{DSS}	Drain to SOURCE (Note 5)	-0.7 to 710	V
V _{CC}	V _{CC} to SOURCE (Note 5)	-0.7 to 6.5	V
P _D	Continuous Power Dissipation (T _A = +25°C) SOT25	0.625	W
T _J	Operating Junction Temperature	+150	°C
T _{STG}	Storage Temperature	-65 to +150	°C
T _{LEAD}	Lead Temperature (Soldering, 10 sec)	+300	°C
θ _{JA}	θ _{JA} Thermal Resistance (Junction to Ambient) SOT25 (Note 6)	125	°C/W
θ _{JC}	θ _{JC} Thermal Resistance (Junction to Case) SOT25 (Note 6)	37	°C/W
ESD	ESD (Human Body Model)	2000	V
	ESD (Charge Device Model)	1000	V

Note 4: Stresses greater than those listed under “*Absolute Maximum Ratings*” can cause permanent damage to the device. These are stress ratings only and functional operation of the device at these or any other condition beyond those indicated under “*Recommended Operating Conditions*” is not implied. Exposure to “*Absolute Maximum Ratings*” for extended periods can affect device reliability.

Note 5: Device has passed qualification test in condition of V_{DSS} = 560V, V_{CC} = 5V for AL17051V5 and in V_{CC} = 3.4V for AL17051V33.

Note 6: Device mounted on the JEDEC High-K board: 3inch × 3inch with 1oz internal power and ground planes and 2oz copper traces on the top and bottom of the board.

Recommended Operating Conditions

Symbol	Parameter	Min	Max	Unit
T _A	Ambient Temperature	-40	+105	°C
I _{out}	Output Current	—	50	mA

Electrical Characteristics (@T_A = +25°C, unless otherwise specified.)

Symbol	Parameter	Condition	Min	Typ	Max	Unit
HV Start-up Current Source						
I _{HV}	HV Supply Current	V _{CC} = 2.5V; V _{DRAIN} = 30V	—	0.7	—	mA
I _{LEAK}	Leakage Current of Drain	V _{CC} = 3.6V; V _{DRAIN} = 560V	—	6	—	μA
VCC Voltage Management						
V _{CC_HV_{OFF}}	HV Supply OFF Threshold Voltage	—	2.83	3.2	3.6	V
V _{CC_HV_{ON}}	HV Supply ON Threshold Voltage	—	2.68	3.05	3.39	V
—	HV Supply ON and OFF Hysteresis	—	—	150	—	mV
V _{CC_REF}	VCC Reference Voltage for Internal MOSFET Turn On (3.3V)	—	3.51	3.60	3.69	V
	VCC Reference Voltage for Internal MOSFET Turn On (5V)	—	5.22	5.35	5.48	V
V _{CC_UVLO}	Min Operating Voltage	—	—	2.7	—	V
I _{CC_FULL}	Operating Current (3.3V)	f _s = 33kHz, D = 35%	—	195	—	μA
	Operating Current (5V)	f _s = 33kHz, D = 35%	—	240	—	μA
I _{CC_QC}	Quiescent Current with No Switching	—	—	88	—	μA
I _{CC_LATCH}	Latch Off Current	—	—	80	—	μA
Internal MOSFET						
V _{DS}	Breakdown Voltage	—	700	—	—	V
R _{DS(ON)}	ON Resistance	—	—	40	—	Ω
Internal Current Sense						
I _{PK_MAX}	Peak Current	—	—	140	—	mA
I _{PK_MIN}	Minimum Peak Current	—	—	60	—	mA
t _{LEB}	Leading Edge Blanking	—	—	300	—	ns
t _{MINOFF}	Minimum Off Time	—	15	18.5	22	μs
Thermal Shutdown						
T _{SD}	Thermal Shutdown Threshold (Note 7)	—	—	+150	—	°C
T _{HYS}	Hysteresis for Recover after OTP (Note 7)	—	—	+50	—	°C

Note: 7. These parameters, although guaranteed by design, are not 100% tested in production.

Performance Characteristics

Quiescent Current vs. Ambient Temperature

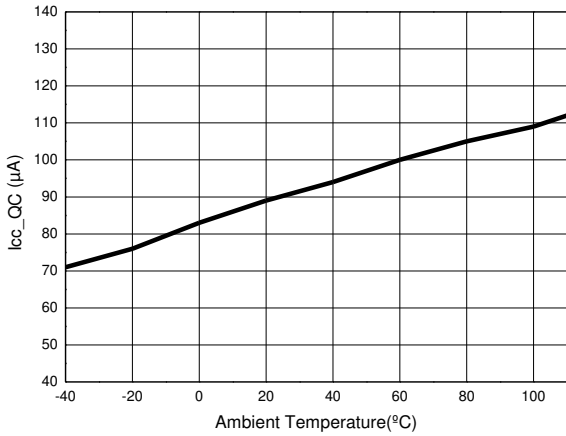

Latch Off Current vs Ambient Temperature

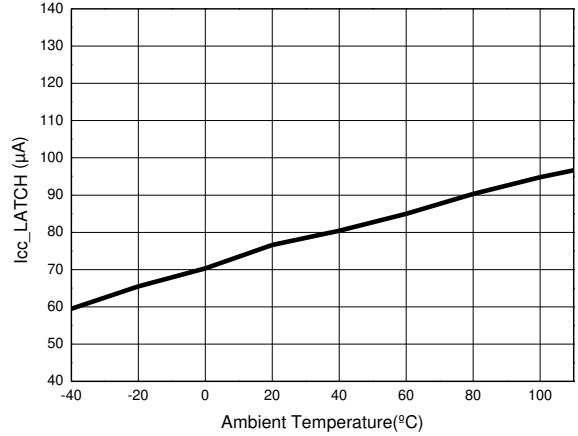

Min Operating vs Ambient Temperature

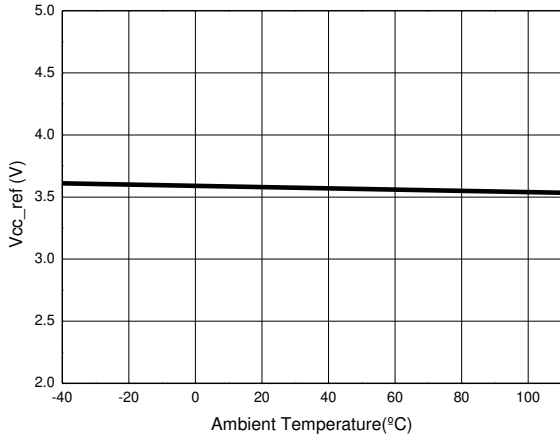

5V VCC vs Ambient Temperature

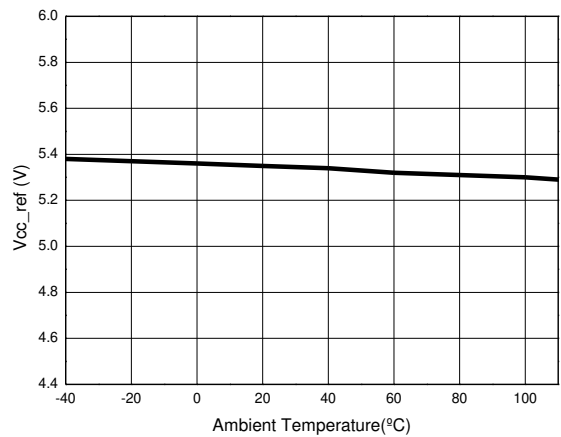

Peak Current vs. Ambient Temperature

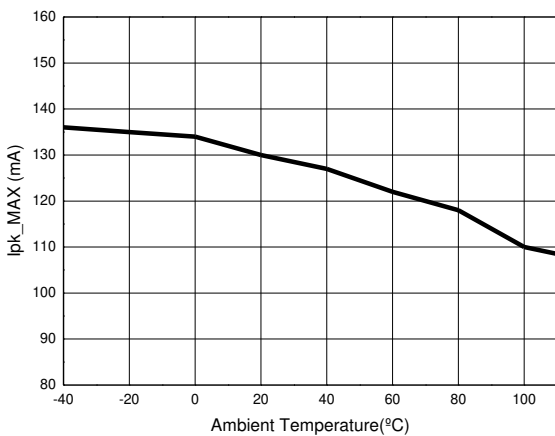

Min Operating vs. Ambient Temperature

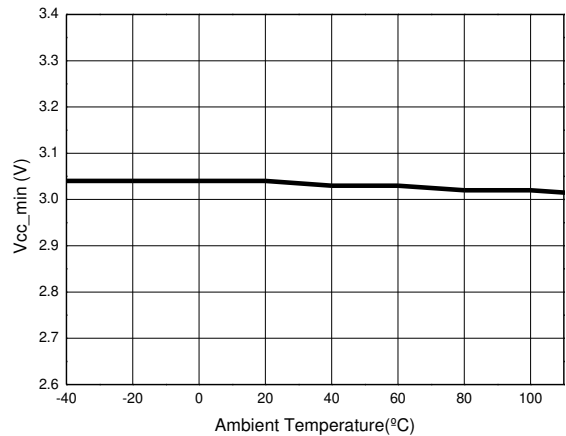

Performance Characteristics (@ $T_A = +25^\circ\text{C}$, unless otherwise specified.)

System Efficiency vs Output Loading

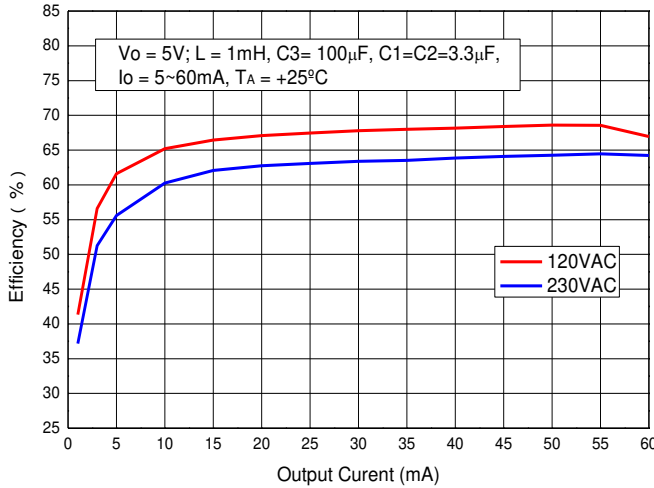

System Efficiency vs Output Loading

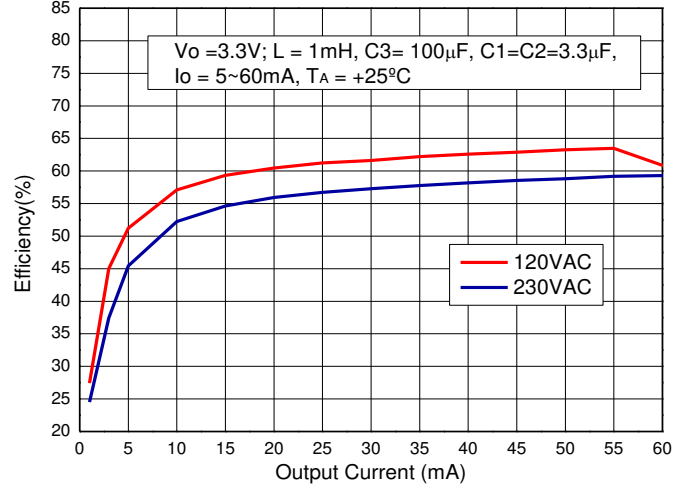

Switching Frequency VS Output Loading

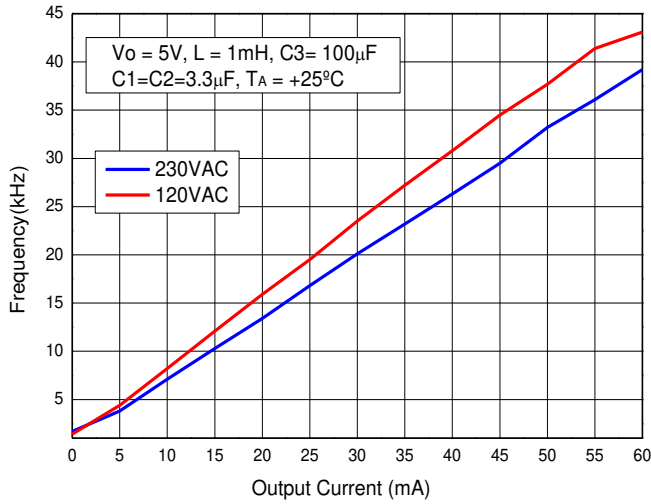

Switching Frequency VS Output Loading

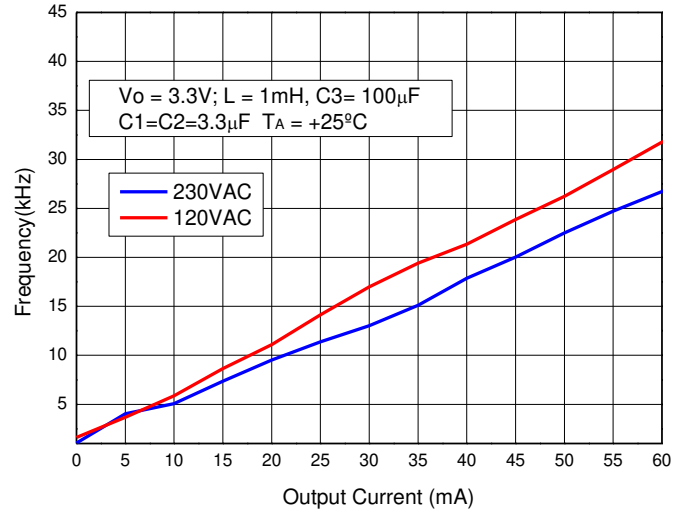

Standby Power VS Input Voltage

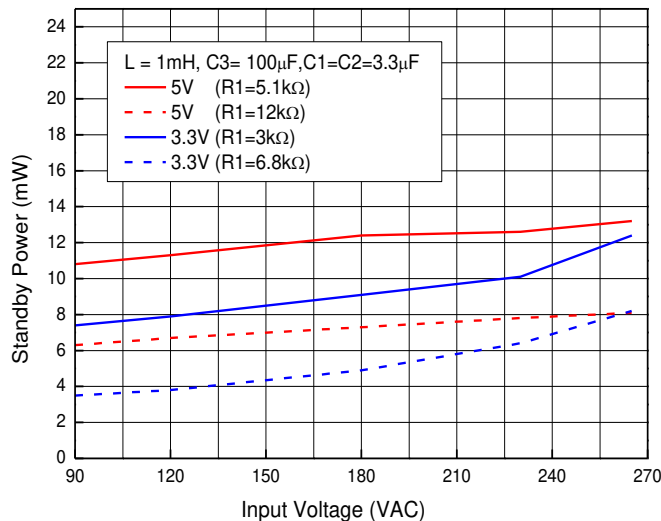

Output Voltage VS Output Current

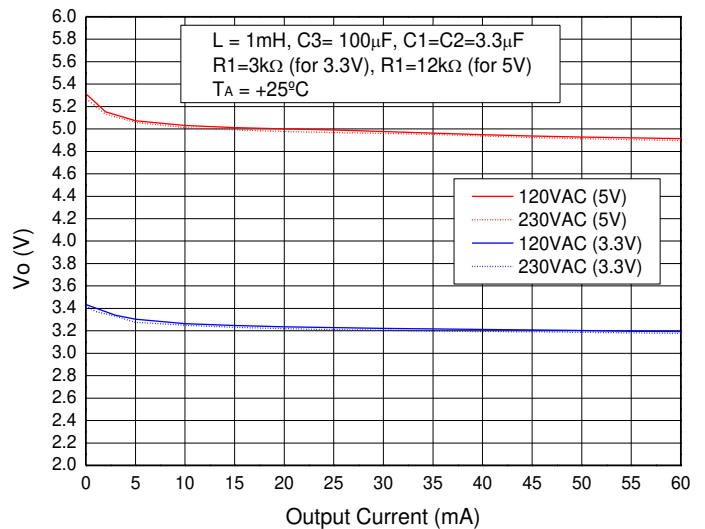

Function Description

Overall Introduction

The AL17051 is a universal AC input step down regulator. Max peak current limitation and driving frequency vary as the load change can get excellent efficiency performance at light load and improve the overall efficiency of system. Working with a single winding inductor and integrating a 700V MOSFET internal can make it use fewer external components and create a low BOM cost solution. Figure 1 shows a typical application example of a Buck power supply.

Converter Operation

Start-up and Under Voltage Lock-out

The IC control voltage VCC is charged by internal high voltage regulator. When the VCC voltage is charged to VCC_HV_{OFF}, IC starts to generate switching signal and meanwhile the internal high voltage regulator is turned off to improve system efficiency; When the VCC voltage drops below VCC_HV_{ON}, the internal high voltage regulator turns on again to charge the external VCC capacitor. When the voltage on VCC drops below VCC_UVLO, the IC stops operating; then the internal high-voltage regulator charges the VCC capacitor. Figure 2 shows the typical waveform with VCC.

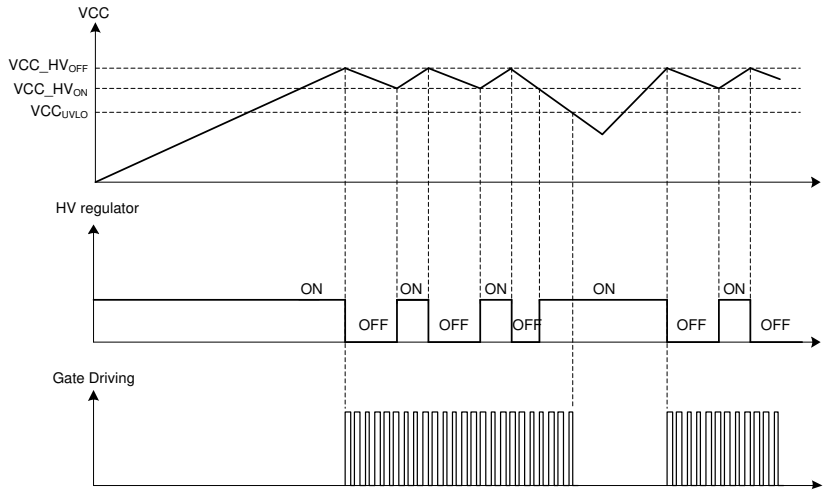

Figure 2 VCC Waveform and HV Regulator ON/OFF Status

Constant Voltage Operation

The AL17051 is a step down regulator with a 700V MOSFET integrated. It can be used in Buck circuit as shown in the *Typical Application Circuit*.

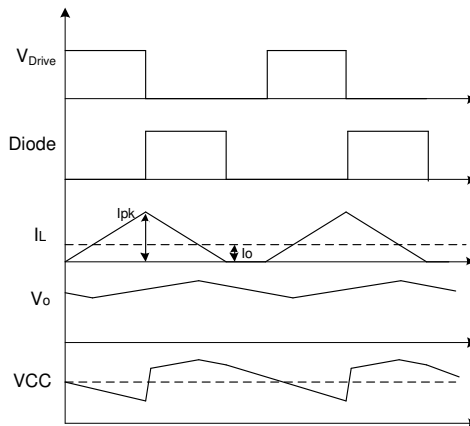

Figure 3 Operation Timing in DCM Mode

The peak current limit and the initial inductance current value altogether with the input voltage determine the ON period time. When the inductor current reaches peak current limit, the internal integrated MOSFET turns OFF. The inductor current charges the VCC capacitor (C₄) and the output capacitor (C₃) via the freewheeling diode D₄ and D₃ respectively. The VCC capacitor voltage is the mapping of the output voltage.

Function Description (continued)

The output voltage can be controlled by sampling the voltage of internal feedback which is derived from the voltage of VCC capacitor. In the OFF stage of internal MOSFET, when the inductor current drops below the output current, the VCC capacitor voltage begins to decrease. When the voltage of internal feedback falls below the reference voltage (2.5V), a new switching cycle begins. Figure 3 shows the detailed operation timing diagram under Discontinuous Conduction Mode (DCM).

Frequency and Peak Current

To maintain high efficiency under different load condition, AL17051 adjusts the switching frequency automatically. Since AL17051 should be set to work in DCM mode under full load, the switching frequency can be obtained as:

$$f_s = \frac{2(V_{in}-V_o)}{L \cdot I_{pk}^2} \cdot \frac{I_o V_o}{V_{in}} \dots\dots\dots(1)$$

As the load decreases, the switching frequency decreases and the MOSFET OFF time t_{OFF} increases, leading to the decrease of peak current. In no load condition, in which only a dummy load is retained, the frequency and the peak current are both minimized. This helps to reduce the no load power consumption.

Soft Start Control

The AL17051 implements a minimum OFF time control. In normal condition, the minimum OFF time limit is 18.5 μ s.

In the startup process, the output voltage is not established and more demagnetizing time is needed. Therefore, the soft start technique is adopted. During the startup process, the minimum MOSFET OFF time varies in first 384 switching cycles, and the startup process will end if the desired output voltage is reached.

EA Compensation

To improve load regulation and load transient performance, AL17051 is designed with an error amplifier (EA) compensation function.

The compensation is related to the load condition. With an increasing load, the compensation value increases and the reference voltage of the internal feedback comparator is slightly pulled down. A faster change in the load will lead to a greater compensation step, and then the output voltage will be regulated back to the desired voltage faster. This compensation will precisely maintain the output voltage.

Leading-Edge Blanking

A narrow spike on the leading edge of the current waveform can usually be observed when the power MOSFET is turned on. A built-in 350ns leading-edge blank is to prevent any false-triggering caused by the turn-on spike. During this period, the current limit comparator is disabled and the gate driver cannot be switched off.

Protection

Over-Current Protection (SCP)

The AL17051 enters over current protection mode once the peak current of inductor exceeds the over current protection threshold (200mA). During this event, AL17051 increases t_{MINOFF} to 4 times typical value to let inductor discharge for a longer period of time. The AL17051 will resume operation when the fault is removed.

Over Load Protection (OLP)

When the output load increases, the peak current and the switching frequency will also increase. If AL17051 operates in minimum TOFF mode, the internal OLP counter starts counting the switching cycle. OLP is triggered when the OLP counter reaches 8192 cycles. In OLP mode, device stops switching, the VCC voltage starts to decrease. When VCC voltage drops to V_{CCUVLO} , and then the internal high voltage regulator recharges VCC. After 512 cycles for internal high voltage regulator on/off, AL17051 starts recover to output switching and then check if the over load condition is removed.

Thermal Shutdown (TSD)

AL17051 integrates an internal thermal shutdown protection function. If the IC junction temperature rises above T_{JSTOP} (typical value: +150°C), the thermal shutdown (TSD) protection is triggered and the internal MOSFET stops switching. To recover the switching of internal MOSFET, the IC junction temperature has to fall by a hysteresis of 30°C below the T_{JSTOP} . During TSD protection, VCC drops to $V_{CCRESTART}$ (typical value 2.4V), and then the internal high voltage regulator recharges VCC.

Function Description (continued)

Application and Implementation

AL17051 is a universal high voltage step-down regulator. Figure 1 shows a typical application for reference. The application can be used in a wide variety of home appliances and industrial control devices, or any other application where mains isolation is not required.

Input Stage

The input stage consists of RF₁, D₁, D₂, C₁, C₂ and L₁. Resistor RF₁ is a fusible resistor. RF₁ limits the inrush current, and also provides protection in case any component failure causes a short circuit. Value for its resistance is generally selected between 4.7Ω to 15Ω. A half-wave rectifier is implemented with a general purpose 1A/1000V diode D₁. D₂ is added for improving common-mode conducted EMI noise performance if needed. Component C₁, L₁, C₂ forms a Pi EMI filter; Capacitor C₁ and C₂ also act as storage capacitors for the high-voltage input DC voltage.

When using a half-wave rectifier, select a 2.2μF as input capacitor for the universal input condition. When using a full-wave rectifier, choose 1μF capacitor. To avoid thermal shutdown, capacitance selection must avoid the minimum DC voltage below 70V. If the converter needs to pass surge test, adjusting input capacitance can help to meet different surge test requirements.

Inductor

AL17051 should be set to work in DCM mode under full load. In DCM Buck converter, the inductor peak-to-peak current ripple is the peak current, and it should be bigger than double of the output current.

$$\Delta I_L = I_{pk} > 2 \times I_{out} \dots\dots\dots(2)$$

Therefore, the available output current with AL17051 should be less than half of the peak current limit, generally limited to 60mA.

In DCM mode, the peak current limit and the inductor determine the internal MOSFET turn-on time (t_{on}). And t_{on} can be given by Equation 3.

$$t_{on} = \frac{L \cdot I_{pk}}{V_{in} - V_o} \dots\dots\dots(3)$$

To guarantee normal operation, t_{on} must be bigger than t_{LEB} with margin.

The Buck converter reaches maximum power when the off-time equals the minimum off time (t_{MINOFF}). Thus the maximum output power can be calculated as:

$$P_{omax} = \frac{1}{2} L \cdot I_{pk}^2 \cdot \frac{1}{t_{minoff}} \dots\dots\dots(4)$$

Since the on-time is generally far smaller than the off-time, the above approximation can be reasonable for estimation.

To select an inductor, the desired maximum output power is given according to the output specification. The desired peak current is also estimated, generally between 80mA and 140mA. Since t_{MINOFF} is 18.5μs, a minimum inductance can be calculated with Equation 1, Equation 3, and Equation 4.

With the inductance and its peak current value, a standard off-the-shelf inductor can be used to reduce cost.

Freewheeling Diode

The maximum reverse voltage that the diode would experience during normal operation is given by the following equation.

$$V_{D-MAX} = \sqrt{2} \times V_{INAC-MAX} \dots\dots\dots(5)$$

For a universal AC input application, the 265V_{AC}, thus V_{D-MAX} value is 375V. Considering a margin of 20%, a 600V diode is a general selection.

A fast recovery diode is required for the Buck application. Since AL17051 works in DCM under full load, slower diode can be used, but the reverse recovery time should be kept less than 100ns. If even slower diode is to be chosen, special review is needed.

The forward voltage drop difference caused by D₃ and D₄ cannot be neglected. Since the diode forward voltage is positively related with the current flows through it and the current through D₃ is much higher than D₄, VD₃ is higher than VD₄.

Output Capacitor

The output capacitor maintains the DC output voltage, and the value impacts the output ripple. Since AL17051 works in DCM mode, the output voltage ripple can be estimated as:

$$V_{out_ripple} = \frac{I_{out}}{f_s C_{out}} \cdot \left(\frac{I_{pk} - I_{out}}{I_{pk}} \right) + I_{pk} \cdot R_{ESR} \dots\dots\dots(6)$$

Where f_s is the switching frequency, and R_{ESR} is ESR of output capacitor. For a typical application, the capacitor value can range from 47μF to hundreds of μF. If the total ripple is higher than the requirement, increasing the capacitance and reducing the ESR can help.

Function Description (continued)

Dummy Load

The output requires a dummy load to maintain the load regulation under no-load condition. This can ensure sufficient inductor energy to charge the sample-and-hold capacitor to detect the output voltage. Most applications can use a 1 to 3mA dummy load and the dummy load can be adjusted according to the regulation. Increasing the dummy load adversely affects the efficiency and no-load consumption.

VCC Capacitor

The VCC capacitor provides a sample-and hold function. The VCC capacitor discharge slew should be a little than output capacitor discharge for output load in PWM OFF time. It can make VCC voltage always follow output voltage variation. But the VCC capacitor cannot be too small, VCC voltage will drop too fast and may mis-trigger OLP function in tight output load condition. Hence the capacitance selection should conform to the following equation:

$$0.5 \cdot \frac{I_{CC_QC}}{I_O} \cdot C_3 < C_4 < \frac{I_{CC_QC}}{I_O} \cdot C_3 \dots \dots \dots (7)$$

Layout Guidelines

PCB layout is important to achieve reliable operation, good EMI, and thermal performance. Follow these guidelines to optimize performance:

- Minimize the loop area formed by the input capacitor, IC part, freewheeling diode, inductor and output capacitor.
- Place the power inductor far away from the input filter.
- Connect the exposed pad with the Drain pin to a large copper area to improve thermal performance.

Ordering Information

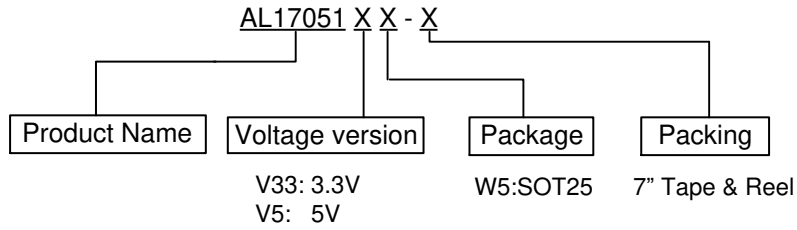

Part Number	Package	Package Code	Marking ID	Packing	
				Qty.	Carrier
AL17051V33W5-7	SOT25	W5	BB	3,000	7" Tape & Reel
AL17051V5W5-7	SOT25	W5	BM	3,000	7" Tape & Reel

Marking Information

(Top View)

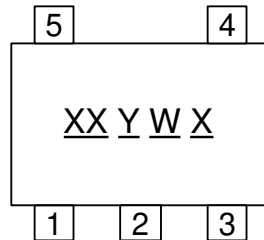

XX : Marking ID
Y : Year 0 to 9
W : Week : A to Z : 1 to 26 week;
 a to z : 27 to 52 week; z represents
 52 and 53 week
X : Internal Code

Mechanical Data

- Moisture Sensitivity: Level 1 per JESD22-A113
- Terminals: Finish - Matte Tin Plated Leads, Solderable per M2003 JESD22-B102 Ⓢ
- Weight: 0.015 grams (Approximate)

Package Outline Dimensions

Please see <http://www.diodes.com/package-outlines.html> for the latest version.

SOT25

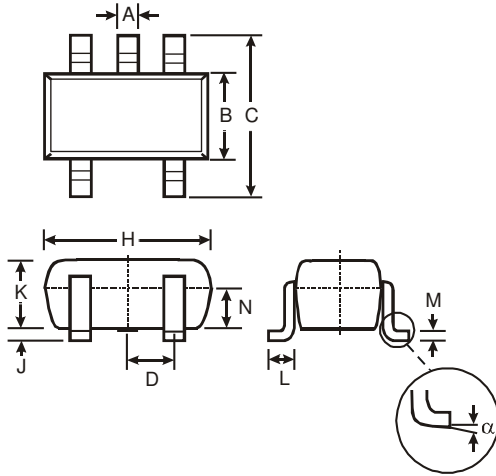

SOT25			
Dim	Min	Max	Typ
A	0.35	0.50	0.38
B	1.50	1.70	1.60
C	2.70	3.00	2.80
D	-	-	0.95
H	2.90	3.10	3.00
J	0.013	0.10	0.05
K	1.00	1.30	1.10
L	0.35	0.55	0.40
M	0.10	0.20	0.15
N	0.70	0.80	0.75
α	0°	8°	-
All Dimensions in mm			

Suggested Pad Layout (Note 8 and Note 9)

Please see <http://www.diodes.com/package-outlines.html> for the latest version.

SOT25

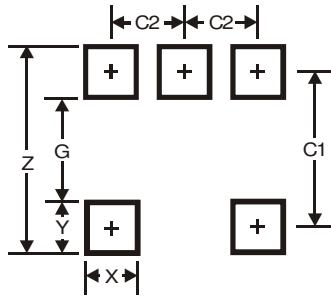

Dimensions	Value (in mm)
Z	3.20
G	1.60
X	0.55
Y	0.80
C1	2.40
C2	0.95

Note 8: The suggested land pattern dimensions have been provided for reference only, as actual pad layouts may vary depending on application. These dimensions may be modified based on user equipment capability or fabrication criteria. A more robust pattern may be desired for wave soldering and is calculated by adding 0.2 mm to the 'Z' dimension. For further information, please reference document IPC-7351A, Naming Convention for Standard SMT Land Patterns, and for International grid details, please see document IEC, Publication 97.

Note 9: For high voltage applications, the appropriate industry sector guidelines should be considered with regards to creepage and clearance distances between device Terminals and PCB tracking.

Device Tape Orientation

Tape Width	Tape Orientation
8mm	<p>Note 10: Analogue Only</p> <p>Direction of feed</p>

Note 10: Tape and package drawings are not to scale and are shown for device tape orientation only.

Embossed Carrier Tape Specification

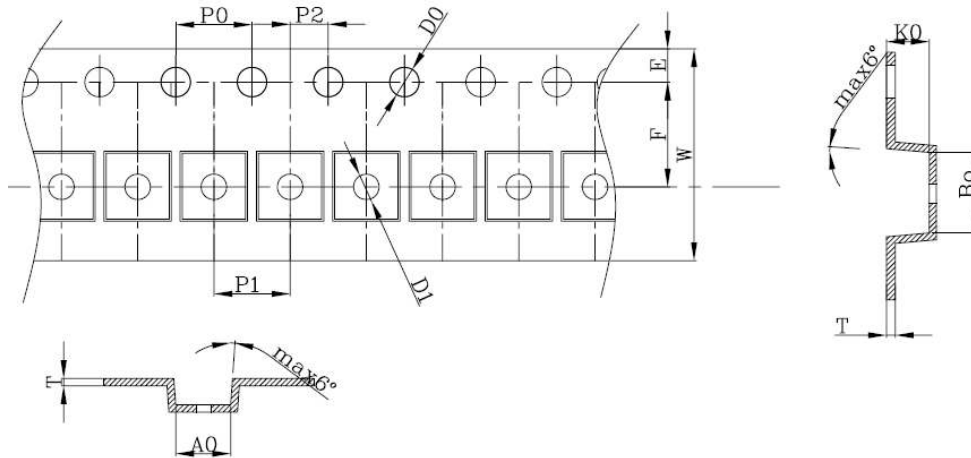

First Source

Tape Width (W)	Dimension	Value (mm)	Dimension	Value (mm)	Dimension	Value (mm)
8mm	A0	3.25 ± 0.1	P1	4.0 ± 0.1	F	3.5 ± 0.05
	B0	3.15 ± 0.1	P2	2 ± 0.05	D0	1.55 ± 0.05
	K0	1.5 ± 0.1	T	0.2 ± 0.02	D1	1.1 ± 0.1
	P0	4.0 ± 0.1	E	1.75 ± 0.1	W	8/+0.3/-0.1
	A0 B0 K0	Determined by component size. The clearance between the component and the cavity must comply to the rotational and lateral movement requirement provided in figures in the "Maximum Component Movement in Tape Pocket" section.				

Second Source

Tape Width (W)	Dimension	Value (mm)	Dimension	Value (mm)	Dimension	Value (mm)
8mm	A0	3.23 ± 0.1	P1	4.0 ± 0.1	F	3.5 ± 0.05
	B0	3.17 ± 0.1	P2	2 ± 0.05	D0	1.50 ± 0.1
	K0	1.37 ± 0.1	T	0.23 ± 0.02	D1	1.0 ± 0.25
	P0	4.0 ± 0.1	E	1.75 ± 0.1	W	8/+0.3/-0.1
	A0 B0 K0	Determined by component size. The clearance between the component and the cavity must comply to the rotational and lateral movement requirement provided in figures in the "Maximum Component Movement in Tape Pocket" section.				

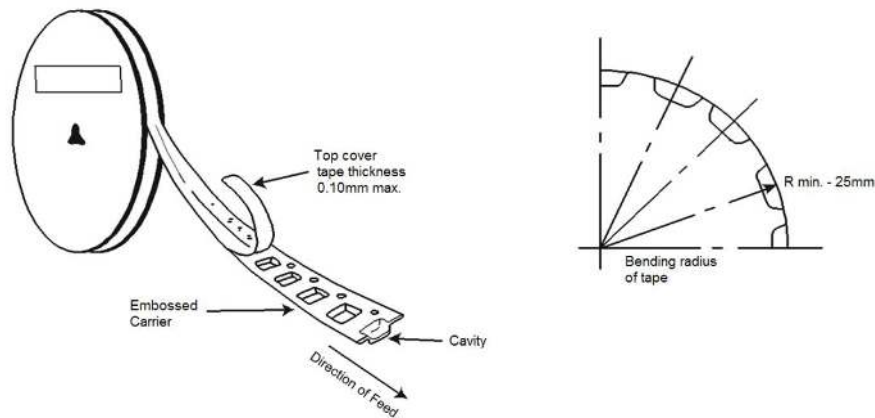

Embossed Carrier Tape Specification (continued)

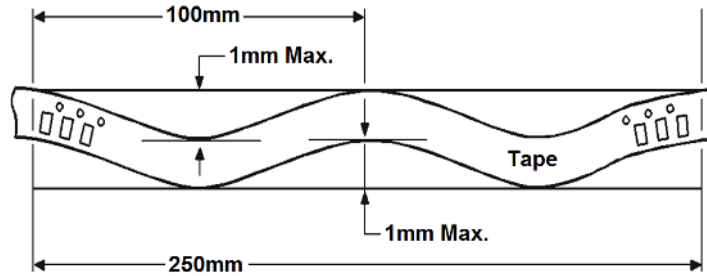

Camber (Top View)

Allowable camber to be 1mm/100mm tape, non-cumulative

Maximum Component Movement in Tape Pocket

Component Lateral Movement

8mm Tape

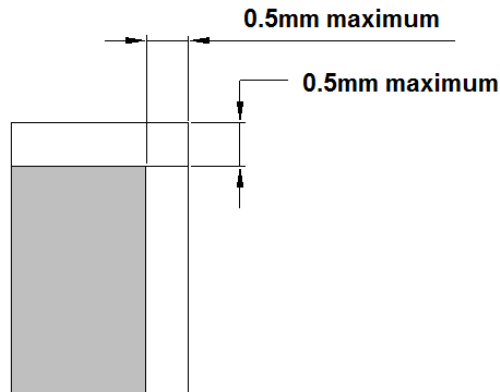

**Maximum Component Rotation
Top View**

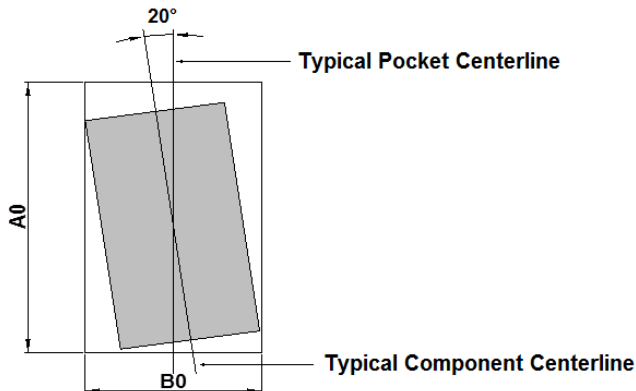

**Maximum Component Rotation
Side View**

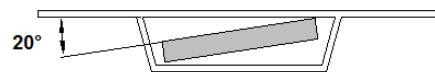

Surface Mount Reel Specifications

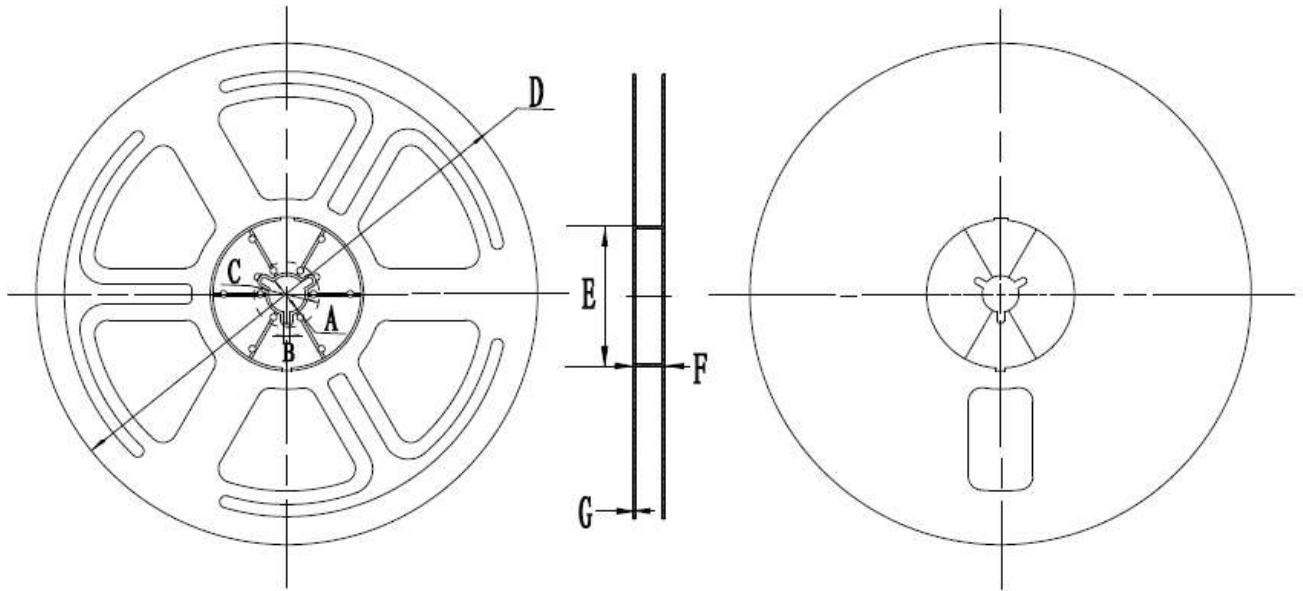

Tape Width	Reel Size	A (mm)	B (mm)	C (mm)	D (mm)	E (mm)	F (mm)	G (mm)
8mm	7"	12.8 to 13.5	≥1.6	≥20.2	Φ178 ± 2	54 to 54.5	8.4 to 9.9	1.4 ± 0.3

Tape Leader and Trailer Specifications (Note 11 and Note 12)

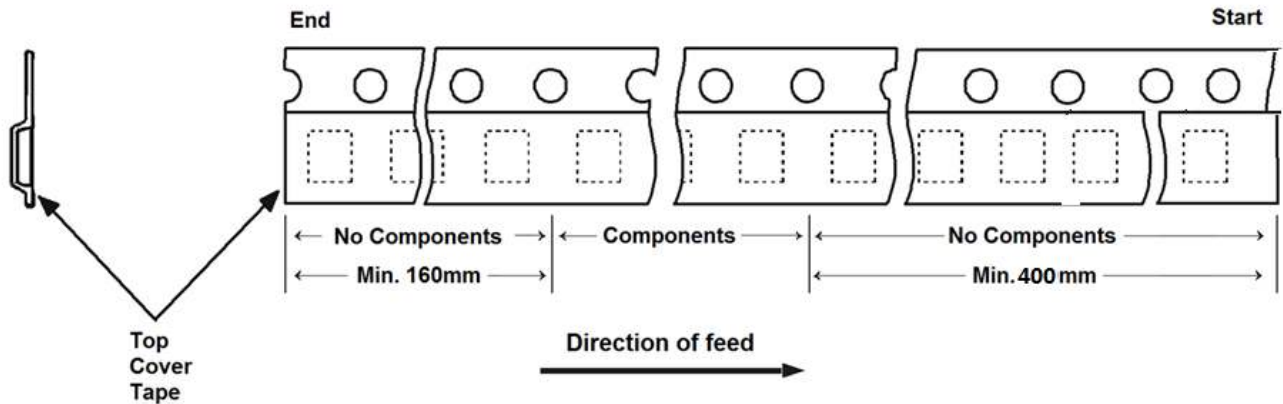

Note 11: There shall be a leader of at least 400mm empty carrier tape sealed with cover tape.

Note 12: There shall be a trailer of at least 160mm of empty carrier tape sealed with cover tape. The entire carrier tape must release from the reel hub as the last portion of the tape unwinds from the reel without damage to the carrier tape and the remaining components in the cavities.

IMPORTANT NOTICE

1. DIODES INCORPORATED (Diodes) AND ITS SUBSIDIARIES MAKE NO WARRANTY OF ANY KIND, EXPRESS OR IMPLIED, WITH REGARDS TO ANY INFORMATION CONTAINED IN THIS DOCUMENT, INCLUDING, BUT NOT LIMITED TO, THE IMPLIED WARRANTIES OF MERCHANTABILITY, FITNESS FOR A PARTICULAR PURPOSE OR NON-INFRINGEMENT OF THIRD PARTY INTELLECTUAL PROPERTY RIGHTS (AND THEIR EQUIVALENTS UNDER THE LAWS OF ANY JURISDICTION).
2. The Information contained herein is for informational purpose only and is provided only to illustrate the operation of Diodes' products described herein and application examples. Diodes does not assume any liability arising out of the application or use of this document or any product described herein. This document is intended for skilled and technically trained engineering customers and users who design with Diodes' products. Diodes' products may be used to facilitate safety-related applications; however, in all instances customers and users are responsible for (a) selecting the appropriate Diodes products for their applications, (b) evaluating the suitability of Diodes' products for their intended applications, (c) ensuring their applications, which incorporate Diodes' products, comply the applicable legal and regulatory requirements as well as safety and functional-safety related standards, and (d) ensuring they design with appropriate safeguards (including testing, validation, quality control techniques, redundancy, malfunction prevention, and appropriate treatment for aging degradation) to minimize the risks associated with their applications.
3. Diodes assumes no liability for any application-related information, support, assistance or feedback that may be provided by Diodes from time to time. Any customer or user of this document or products described herein will assume all risks and liabilities associated with such use, and will hold Diodes and all companies whose products are represented herein or on Diodes' websites, harmless against all damages and liabilities.
4. Products described herein may be covered by one or more United States, international or foreign patents and pending patent applications. Product names and markings noted herein may also be covered by one or more United States, international or foreign trademarks and trademark applications. Diodes does not convey any license under any of its intellectual property rights or the rights of any third parties (including third parties whose products and services may be described in this document or on Diodes' website) under this document.
5. Diodes' products are provided subject to Diodes' Standard Terms and Conditions of Sale (<https://www.diodes.com/about/company/terms-and-conditions/terms-and-conditions-of-sales/>) or other applicable terms. This document does not alter or expand the applicable warranties provided by Diodes. Diodes does not warrant or accept any liability whatsoever in respect of any products purchased through unauthorized sales channel.
6. Diodes' products and technology may not be used for or incorporated into any products or systems whose manufacture, use or sale is prohibited under any applicable laws and regulations. Should customers or users use Diodes' products in contravention of any applicable laws or regulations, or for any unintended or unauthorized application, customers and users will (a) be solely responsible for any damages, losses or penalties arising in connection therewith or as a result thereof, and (b) indemnify and hold Diodes and its representatives and agents harmless against any and all claims, damages, expenses, and attorney fees arising out of, directly or indirectly, any claim relating to any noncompliance with the applicable laws and regulations, as well as any unintended or unauthorized application.
7. While efforts have been made to ensure the information contained in this document is accurate, complete and current, it may contain technical inaccuracies, omissions and typographical errors. Diodes does not warrant that information contained in this document is error-free and Diodes is under no obligation to update or otherwise correct this information. Notwithstanding the foregoing, Diodes reserves the right to make modifications, enhancements, improvements, corrections or other changes without further notice to this document and any product described herein. This document is written in English but may be translated into multiple languages for reference. Only the English version of this document is the final and determinative format released by Diodes.
8. Any unauthorized copying, modification, distribution, transmission, display or other use of this document (or any portion hereof) is prohibited. Diodes assumes no responsibility for any losses incurred by the customers or users or any third parties arising from any such unauthorized use.
9. This Notice may be periodically updated with the most recent version available at <https://www.diodes.com/about/company/terms-and-conditions/important-notice>

DIODES is a trademark of Diodes Incorporated in the United States and other countries.
The Diodes logo is a registered trademark of Diodes Incorporated in the United States and other countries.
© 2022 Diodes Incorporated. All Rights Reserved.

www.diodes.com