

SMA
Reverse

Adaptor
Reverse SMA Jack –
SMA Plug

32RK132-S00L5

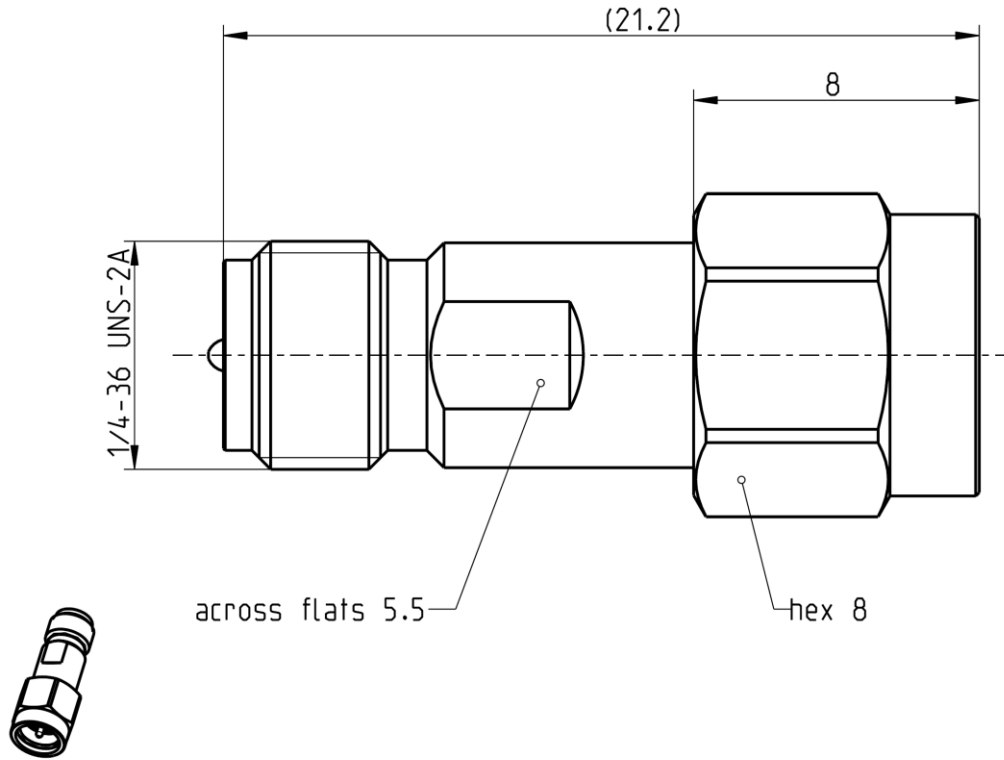

All dimensions are in mm; tolerances according to ISO 2768 m-H

Interface

Reverse SMA side:	According to Compliant with Derived from	Rosenberger SMA Reverse FCC standard (part 15, section 15.203) IEC 60169-15, EN 122110, MIL-PRF-39012
SMA side:	According to	IEC 60169-15; EN 122110; MIL-STD-348A, Fig. 310

Documents

N/A

Material and plating

Connector parts

Center contact
Outer contact
Dielectric
Gasket
Coupling nut

Material

Brass
CuBe or equiv.
PTFE
Silicone
CuBe or equiv.

Plating

AuroDur®, gold plated
AuroDur®, gold plated

Gold, 0.1 µm

SMA
Reverse

Adaptor
Reverse SMA Jack –
SMA Plug

32RK132-S00L5

Electrical data

Impedance	50 Ω	
Frequency	DC to 18 GHz	
VSWR	≤ 1.05 + 0.005 x f [GHz]	
Insertion loss	≤ 0.05 x √f(GHz) dB	
Insulation resistance	≥ 5 x10 ³ MΩ	
Center contact resistance	≤ 3 mΩ, reverse SMA side;	≤ 3 mΩ, SMA side
Outer contact resistance	≤ 2 mΩ, reverse SMA side;	≤ 2 mΩ, SMA side
Test voltage	1000 V rms	
Working voltage	480 V rms	
Power handling (at 20 °C, sea level, VSWR 1.0)	≤ 200 W @ 2 GHz	
RF-leakage	≥ 100 dB up to 1 GHz	

Mechanical data

	Reverse SMA side	SMA side
Mating cycles	min. 500	min. 500
Coupling nut retention	N/A	≥ 270 N
Center contact captivation: axial	≥ 27 N	≥ 27 N
radial	≥ 3 Ncm	≥ 3 Ncm
Coupling test torque	max. 1.7 Nm	max. 1.7 Nm
Recommended torque	0.8 Nm to 1.1 Nm	0.8 Nm to 1.1 Nm

Environmental data

Temperature range	-65°C to +165°C
Thermal shock	MIL-STD-202, Meth. 107, Cond. B
Corrosion	MIL-STD-202, Meth. 101, Cond. B
Vibration	MIL-STD-202, Meth. 204, Cond. D
Shock	MIL-STD-202, Meth. 213, Cond. I
Moisture resistance	MIL-STD-202, Meth. 106
RoHS	compliant

Tooling

N/A

Suitable cables

N/A

Weight

Weight 4 g/pce

While the information has been carefully compiled to the best of our knowledge, nothing is intended as representation or warranty on our part and no statement herein shall be construed as recommendation to infringe existing patents. In the effort to improve our products, we reserve the right to make changes judged to be necessary.

For the installation of the electrotechnical equipment, particular electrotechnical expertise is required.



Dieses Dokument ist urheberrechtlich geschützt • This document is protected by copyright • Rosenberger Hochfrequenztechnik GmbH & Co. KG

RF_35/09.14/6.2

Draft	Date	Approved	Date	Rev.	Engineering change number	Name	Date
Chr. Entsfellner	30.01.08	Chr. Janßen	11.11.20	e00	20-1927	S. Huber-Siegl	11.11.20
Rosenberger Hochfrequenztechnik GmbH & Co. KG P.O.Box 1260 D-84526 Tittmoning Germany www.rosenberger.de						Tel. : +49 8684 18-0 Email : info@rosenberger.de	
						Page 2 / 2	