

High Performance 45-A Synchronous Buck EVM Using the TPS5210

User's Guide

IMPORTANT NOTICE

Texas Instruments and its subsidiaries (TI) reserve the right to make changes to their products or to discontinue any product or service without notice, and advise customers to obtain the latest version of relevant information to verify, before placing orders, that information being relied on is current and complete. All products are sold subject to the terms and conditions of sale supplied at the time of order acknowledgement, including those pertaining to warranty, patent infringement, and limitation of liability.

TI warrants performance of its semiconductor products to the specifications applicable at the time of sale in accordance with TI's standard warranty. Testing and other quality control techniques are utilized to the extent TI deems necessary to support this warranty. Specific testing of all parameters of each device is not necessarily performed, except those mandated by government requirements.

CERTAIN APPLICATIONS USING SEMICONDUCTOR PRODUCTS MAY INVOLVE POTENTIAL RISKS OF DEATH, PERSONAL INJURY, OR SEVERE PROPERTY OR ENVIRONMENTAL DAMAGE ("CRITICAL APPLICATIONS"). TI SEMICONDUCTOR PRODUCTS ARE NOT DESIGNED, AUTHORIZED, OR WARRANTED TO BE SUITABLE FOR USE IN LIFE-SUPPORT DEVICES OR SYSTEMS OR OTHER CRITICAL APPLICATIONS. INCLUSION OF TI PRODUCTS IN SUCH APPLICATIONS IS UNDERSTOOD TO BE FULLY AT THE CUSTOMER'S RISK.

In order to minimize risks associated with the customer's applications, adequate design and operating safeguards must be provided by the customer to minimize inherent or procedural hazards.

TI assumes no liability for applications assistance or customer product design. TI does not warrant or represent that any license, either express or implied, is granted under any patent right, copyright, mask work right, or other intellectual property right of TI covering or relating to any combination, machine, or process in which such semiconductor products or services might be or are used. TI's publication of information regarding any third party's products or services does not constitute TI's approval, warranty or endorsement thereof.

Read This First

About This Manual

This user's guide describes the TPS5210EVM-126 (SLVP126), a 45-A synchronous buck converter evaluation module (EVM). The SLVP126 provides a convenient method to evaluate the performance of a high-current synchronous buck converter using the TPS5210 ripple regulator controller. A complete and tested power supply design is presented, and detailed test results for the SLVP126 EVM are included.

How to Use This Manual

This document contains the following chapters:

- Chapter 1 Introduction contains the design summary, performance specifications, and voltage identification codes.
- Chapter 2 Schematic contains the schematic diagram.
- Chapter 3 Board Layout and I/O Connections contains board layout and I/O connection drawings.
- Chapter 4 Bill of Materials contains the bill of materials for the EVM.
- Chapter 5 Test Results contains test data for the EVM.

Related Documentation From Texas Instruments

- 1) *Designing Fast Response Synchronous Buck Converters Using the TPS5210* Application Report, Literature Number SLVA044.
- 2) *TPS5210 Programmable Synchronous-Buck Regulator Controller* Data Sheet, Literature Number SLVS171.
- 3) *VRM 8.3 DC-DC Converter Design Guidelines* Intel document Order number: 243870–001, June 1998.

FCC Warning

This equipment is intended for use in a laboratory test environment only. It generates, uses, and can radiate radio frequency energy and has not been tested

for compliance with the limits of computing devices pursuant to subpart J of part 15 of FCC rules, which are designed to provide reasonable protection against radio frequency interference. Operation of this equipment in other environments may cause interference with radio communications, in which case the user at his own expense will be required to take whatever measures may be required to correct this interference.

Trademarks

CopperStrap is a trademark of International Rectifier.

Contents

1	Introduction	1-1
1.1	Background	1-2
1.2	Design Summary	1-3
1.3	Performance Specification Summary	1-4
1.4	Voltage Identification Codes	1-5
2	Schematic	2-1
2.1	Schematic Diagram	2-2
3	Board Layout and I/O Connections	3-1
3.1	Board Layout	3-2
3.2	Input/Output Connections	3-3
4	Bill of Materials	4-1
4.1	Bill of Materials	4-2
5	Test Results	5-1
5.1	Test Summary	5-2
5.1.1	Test Conditions	5-2
5.1.2	Static Line and Load Regulation	5-2
5.1.3	Output Voltage Ripple	5-2
5.1.4	Efficiency and Power Losses	5-2
5.1.5	Output Start-Up and Overshoot	5-3
5.1.6	Frequency Variation	5-3
5.1.7	Load Current Transient Response	5-3
5.1.8	Features	5-3
5.1.9	Test Data	5-4
5.1.10	Conclusion	5-10

Figures

2-1	SLVP126 Schematic Diagram	2-3
3-1	SLVP126 Board Layout	3-2
3-2	SLVP126 Assembled PWB	3-3
3-3	SLVP126 Input/Output Connections	3-3
5-1	SLVP126 Measured Line and Load Regulation	5-4
5-2	SLVP126 Measured Efficiency	5-5
5-3	SLVP126 Measured Power Dissipation	5-5
5-4	SLVP126 Measured Switching Frequency	5-6
5-5	SLVP126 Measured Switching Waveforms	5-7
5-6	SLVP126 Measured Start-Up (VCC) Waveforms	5-8
5-7	SLVP126 Measured Start-Up (Enable) Waveforms	5-9
5-8	SLVP126 Measured Load Transient Response	5-10

Tables

1-1	Performance Specification Summary	1-4
1-2	Voltage Identification Codes	1-5
4-1	SLVP126 Bill of Materials	4-2

Introduction

This user's guide describes the TPS5210EVM-126 (SLVP126), a 45-A synchronous buck converter evaluation module (EVM). The SLVP126 provides a convenient method to evaluate the performance of a high-current synchronous buck converter using the TPS5210 ripple regulator controller. A complete and tested power supply design is presented, and detailed test results for the SLVP126 EVM are included. The power supply is a programmable step-down dc-dc EVM that delivers up to 45 A of continuous current, at an output voltage that is programmable from 1.3 V to 3.5 V, determined by a 5-bit DAC code. The PWB board layout provides test points for viewing waveforms.

Topic	Page
1.1 Background	1-2
1.2 Design Summary	1-3
1.3 Performance Specification Summary	1-4
1.4 Voltage Identification Codes	1-5

1.1 Background

High performance microprocessors may require 40 to 80 W of power for the CPU alone. Load current must be supplied at up to 30 A/ μ s slew rate, and the output voltage must be kept within tight regulation and response time tolerances. Parasitic interconnect impedances between the power supply and the processor must be kept to a minimum. Fast responding synchronous buck dc/dc converters controlled by the Texas Instruments TPS5210 hysteretic controller are ideally suited for microprocessor power applications requiring fast response and precise regulation of rapidly changing loads.

Conventional synchronous regulator control techniques include fixed frequency voltage-mode, fixed frequency current-mode, variable frequency current-mode, variable on-time, or variable off-time. CPU power supplies that use these control methods require additional bulk storage capacitors on the output to regulate V_O within limits during the high di/dt load transients because of the limited bandwidth of the controller. Some controllers add a fast loop around the slower main control loop to improve the response time, but V_O must deviate outside a fixed tolerance band before the fast loop becomes active. The TPS5210 hysteretic control method offers superior performance without additional output capacitance or difficult loop compensation design.

The SLVP126 EVM is a modified version of the SLVP119 EVM (see Texas Instruments literature number SLVU010) optimized for high current, high efficiency, and main power input voltage of 12 V; it maintains tight static and dynamic output voltage regulation. The EVM also requires a 5-V, 30-mA input voltage for enable/inhibit and power good signals.

1.2 Design Summary

The SLVP126 EVM is a modification of the SLVP119 EVM. The following design changes from the SLVP119 EVM provide 45 A of output current (vs 20 A for the SLVP119 EVM).

- The output inductor is a 1- μ H, planar construction inductor designed by Pulse Engineering Inc. (P/N P1605) in accordance with TI's requirements.
- The main power switches are high-current, high-efficiency power MOS-FETs from International Rectifier (P/N IRF7811) in an SO-8 package with CopperStrap™ technology.
- The PWB is fabricated with 4-oz. copper to improve thermal characteristics and avoid expensive heatsinks.
- Input and output filters are designed for the increase in output current.

The SLVP126 EVM has all the features, which are described in detail in the datasheet for TPS5210 controller (Texas Instruments literature number SLVS171A). The features include undervoltage lockout, an inhibit signal, a power good signal, overvoltage protection, slow start, remote sense, and overcurrent protection. Current limit is set at 46 A.

1.3 Performance Specification Summary

This section summarizes the performance specifications of the SLVP126 converter. Table 1–1 gives the performance specifications of the converters.

Table 1–1. Performance Specification Summary

Specification		Test Conditions	Min	Typ	Max	Units
Input voltage range	Main power (V_I)		11.4		13	
	5-V Input		4.5	5	5.5	V
	12-V Input		11.4	12	13	V
Output voltage range		See Note 1	1.3	2	3.5	V
Static voltage tolerance		See Notes 2 and 3	1.98	2	2.02	V
Line regulation		See Notes 1 and 4		$\pm 0.05\%$	$\pm 0.1\%$	
Load regulation		See Notes 5 and 6		$\pm 0.1\%$	$\pm 0.4\%$	
Transient response		See Note 7		± 55		mV pk
				50		μsec
Output current range		See Note 4	0		45	A
Current limit		See Note 4		46		A
Output ripple		See Note 4		35		mV
Soft-start rise time		See Note 5		10		ms
Operating frequency		See Notes 1 and 5		125		kHz
Efficiency, 10 A load		See Notes 2 and 4		92.3%		
Efficiency, 45 A load		See Notes 2 and 4		85%		

- Notes:**
- 1) $I_O = 45$ A
 - 2) VID inputs set for $V_{REF} = 2$ V.
 - 3) $I_O = 20$ A
 - 4) Input voltage varied, can be at any point over entire range.
 - 5) Main power input voltage adjusted to 12 VDC.
 - 6) I_O varied, can be at any point over entire range. Droop disabled.
 - 7) I_O pulsed from 0 A to 10 A, $di/dt = 20$ A/ μs .

1.4 Voltage Identification Codes

The output voltage is programmed by driving the 5 VID inputs. The output voltage for a given VID input is shown in Table 1–2.

Table 1–2. Voltage Identification Codes

VID Terminals (0 = GND, 1 = floating or pullup to 5 V)					VREF (Vdc)
VID4	VID3	VID2	VID1	VID0	
0	1	1	1	1	1.30
0	1	1	0	1	1.40
0	1	1	0	0	1.45
0	1	0	1	1	1.50
0	1	0	1	0	1.55
0	1	0	0	1	1.60
0	1	0	0	0	1.65
0	0	1	1	1	1.70
0	0	1	1	0	1.75
0	0	1	0	1	1.80
0	0	1	0	0	1.85
0	0	0	1	1	1.90
0	0	0	1	0	1.95
0	0	0	0	1	2.00
0	0	0	0	0	2.05
1	1	1	1	1	No CPU
1	1	1	1	0	2.10
1	1	1	0	1	2.20
1	1	1	0	0	2.30
1	1	0	1	1	2.40
1	1	0	1	0	2.50
1	1	0	0	1	2.60
1	1	0	0	0	2.70
1	0	1	1	1	2.80
1	0	1	1	0	2.90
1	0	1	0	1	3.00
1	0	1	0	0	3.10
1	0	0	1	1	3.20
1	0	0	1	0	3.30
1	0	0	0	1	3.40
1	0	0	0	0	3.50



Schematic



This chapter contains the schematic diagram for the SLVP126 EVM.

Topic	Page
2.1 Schematic Diagram	2-2

2.1 Schematic Diagram

Figure 2–1 shows the SLVP126 EVM schematic diagram.

Figure 2-1. SLVP126 Schematic Diagram

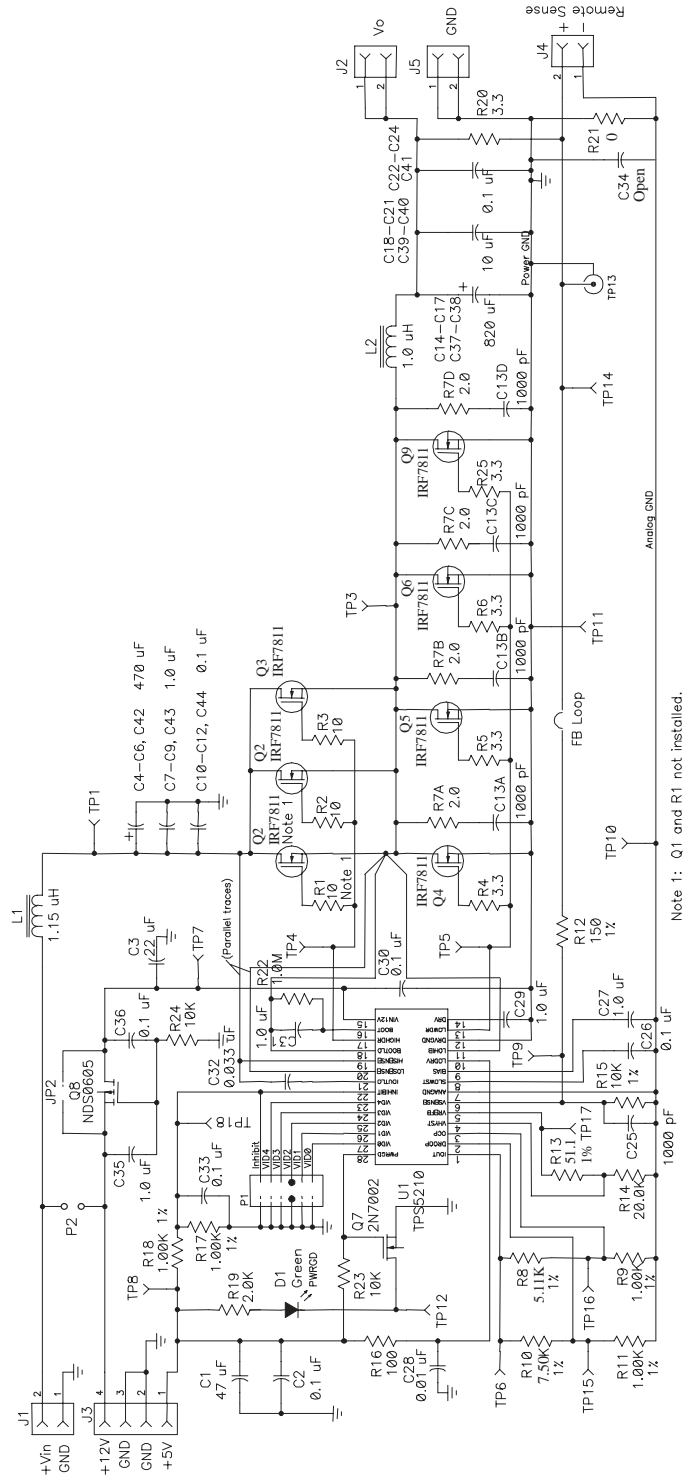

Board Layout and I/O Connections

This chapter contains the board layout and I/O connection drawings for the SLVP126 EVM.

Topic	Page
3.1 Board Layout	3-2
3.2 Input/Output Connections	3-3

3.1 Board Layout

The power supply module consists of one PWB. The board layout includes many test points so that waveforms may be viewed during operation. Figure 3–1 shows the front view and back view of the SLVP126 EVM board, and Figure 3–2 shows the assembled PWB.

Figure 3–1. SLVP126 Board Layout

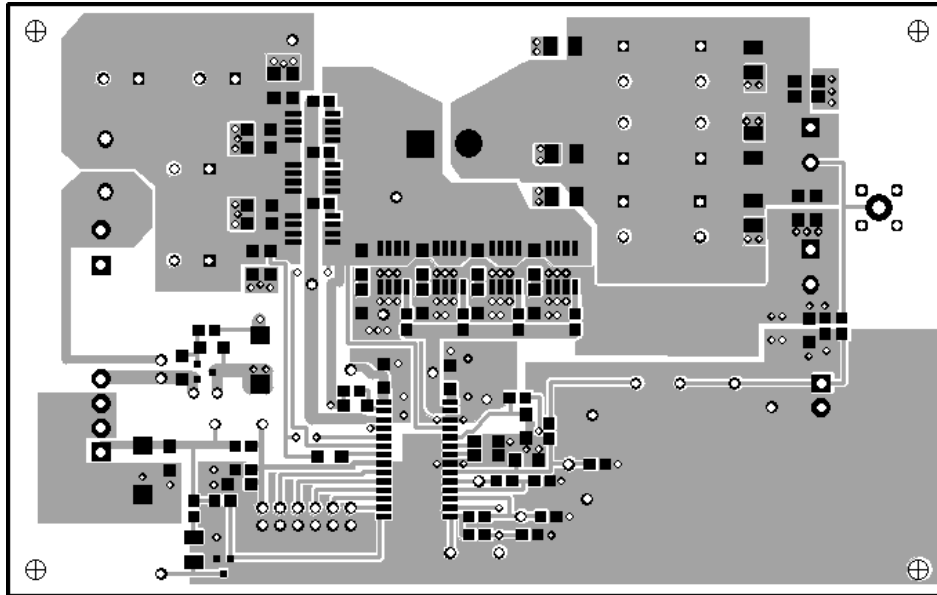

Top Layer

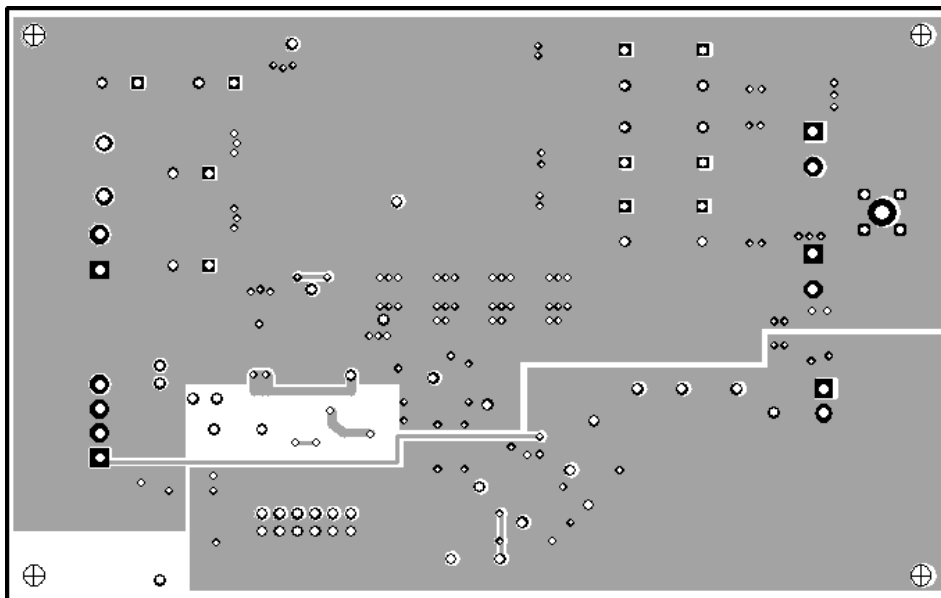

Bottom Layer (Top View)

Figure 3–2. SLVP126 Assembled PWB

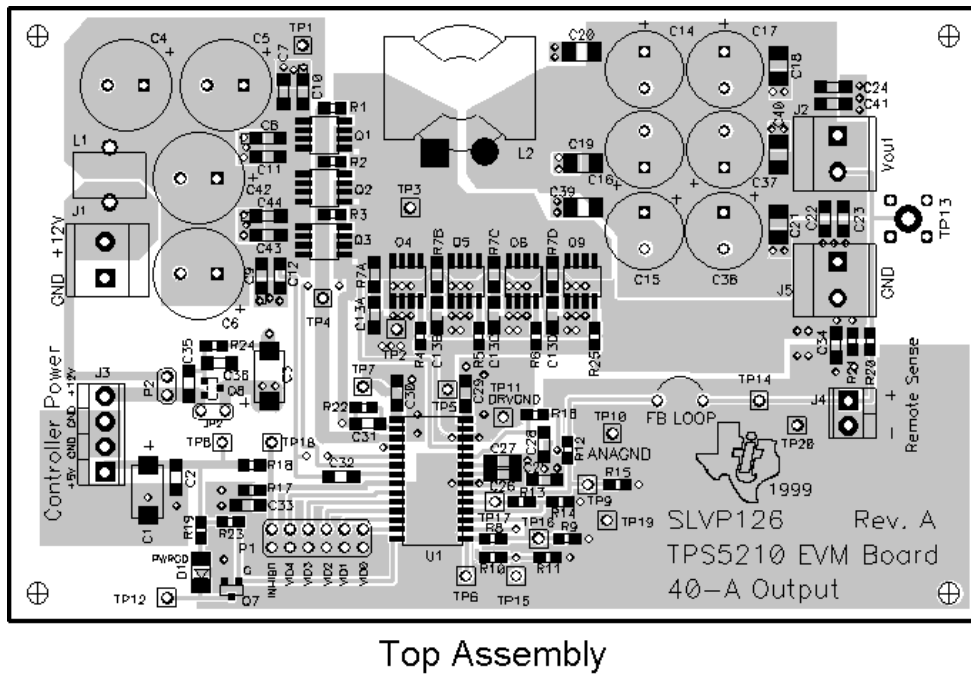

3.2 Input/Output Connections

Figure 3–3 shows the input/output connections to the SLVP126.

Figure 3–3. SLVP126 Input/Output Connections

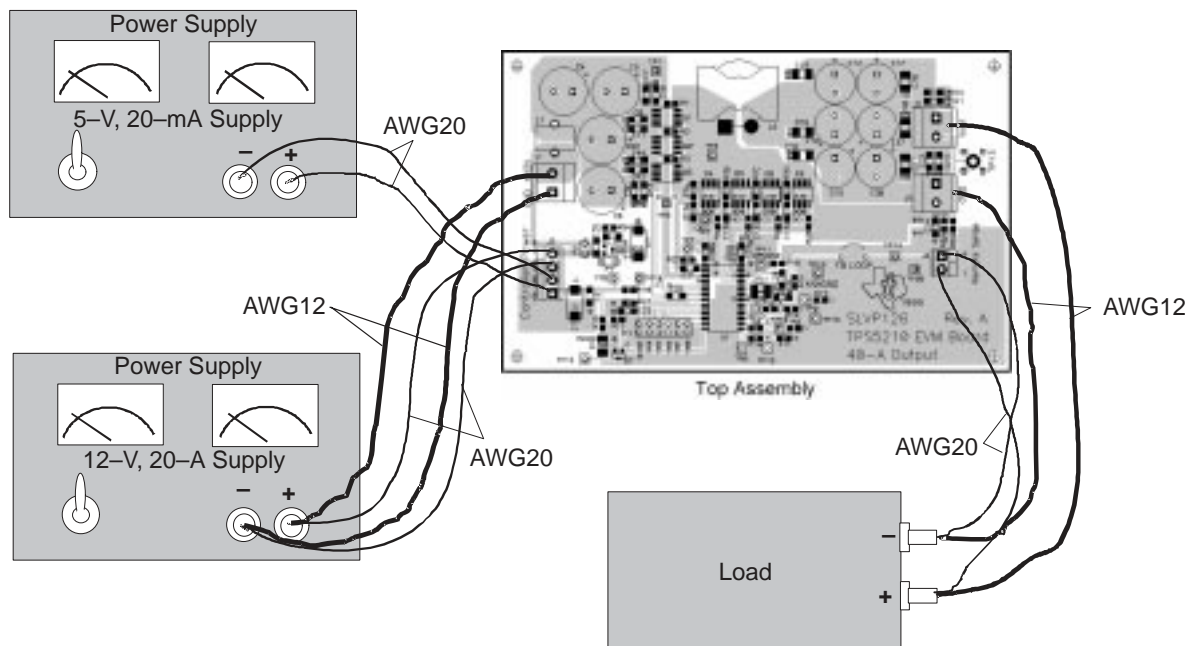

Note: All wire pairs should be twisted.



Bill of Materials

This chapter contains the bill of materials for the SLVP126 EVM.

Topic	Page
4.1 Bill of Materials	4-2

4.1 Bill of Materials

Table 4–1 lists materials required for the SLVP126 EVM.

Table 4–1. SLVP126 Bill of Materials

Ref Des	Part Number	Description	MFG
C1	ECS-H1AD476R	Capacitor, tantalum, 47 μ F, 10 V, 20%	Panasonic
C2	GRM42-6X7R104K050A	Capacitor, ceramic, 0.1 μ F, 50 V, 10%, X7R	muRata
C3	ECS-H1CD226R	Capacitor, tantalum, 22 μ F, 16 V, 20%	Panasonic
C4	16SA470M	Capacitor, Os-Con, 470 μ F, 16 V, 20%	Sanyo
C5	16SA470M	Capacitor, Os-Con, 470 μ F, 16 V, 20%	Sanyo
C6	16SA470M	Capacitor, Os-Con, 470 μ F, 16 V, 20%	Sanyo
C7	GRM42-6Y5V105Z025A	Capacitor, ceramic, 1 μ F, 25 V, +80%-20%, Y5V	muRata
C8	GRM42-6Y5V105Z025A	Capacitor, ceramic, 1 μ F, 25 V, +80%-20%, Y5V	muRata
C9	GRM42-6Y5V105Z025A	Capacitor, ceramic, 1 μ F, 25 V, +80%-20%, Y5V	muRata
C10	GRM42-6X7R104K050A	Capacitor, ceramic, 0.1 μ F, 50 V, 10%, X7R	muRata
C11	GRM42-6X7R104K050A	Capacitor, ceramic, 0.1 μ F, 50 V, 10%, X7R	muRata
C12	GRM42-6X7R104K050A	Capacitor, ceramic, 0.1 μ F, 50 V, 10%, X7R	muRata
C13	GRM42-6X7R102K050A	Capacitor, ceramic, 1000 pF, 50 V, 10%, X7R	muRata
C14	4SP820M	Capacitor, OS-Con, 820 μ F, 4 V, 20%	Sanyo
C15	4SP820M	Capacitor, OS-Con, 820 μ F, 4 V, 20%	Sanyo
C16	4SP820M	Capacitor, OS-Con, 820 μ F, 4 V, 20%	Sanyo
C17	4SP820M	Capacitor, OS-Con, 820 μ F, 4 V, 20%	Sanyo
C18	GRM235Y5V106Z016A	Capacitor, ceramic, 10 μ F, 16 V, Y5V	TDK
C19	GRM235Y5V106Z016A	Capacitor, ceramic, 10 μ F, 16 V, Y5V	TDK
C20	GRM235Y5V106Z016A	Capacitor, ceramic, 10 μ F, 16 V, Y5V	TDK
C21	GRM235Y5V106Z016A	Capacitor, ceramic, 10 μ F, 16 V, Y5V	TDK
C22	GRM42-6X7R104K050A	Capacitor, ceramic, 0.1 μ F, 50 V, 10%, X7R	muRata
C23	GRM42-6X7R104K050A	Capacitor, ceramic, 0.1 μ F, 50 V, 10%, X7R	muRata
C24	GRM42-6X7R104K050A	Capacitor, ceramic, 0.1 μ F, 50 V, 10%, X7R	muRata
C25	GRM42-6X7R102K050A	Capacitor, ceramic, 1000 pF, 50 V, 10%, X7R	muRata
C26	GRM42-6X7R104K050A	Capacitor, ceramic, 0.1 μ F, 50 V, 10%, X7R	muRata
C27	GRM42-6Y5V105Z025A	Capacitor, ceramic, 1 μ F, 25 V, +80%-20%, Y5V	muRata
C28	GRM42-6X7R103K050A	Capacitor, ceramic, 0.01 μ F, 50 V, 10%, X7R	muRata
C29	GRM42-6Y5V105Z025A	Capacitor, ceramic, 1 μ F, 25 V, +80%-20%, Y5V	muRata
C30	GRM42-6X7R104K050A	Capacitor, ceramic, 0.1 μ F, 50 V, 10%, X7R	muRata
C31	GRM42-6Y5V105Z025A	Capacitor, ceramic, 1 μ F, 25 V, +80%-20%, Y5V	muRata

Table 4–1. SLVP126 Bill of Materials (Continued)

Ref Des	Part Number	Description	MFG
C32	GRM42-6X7R333Z050A	Capacitor, ceramic, 0.033 μ F, 50 V, 10%, X7R	muRata
C33	GRM42-6X7R104K050A	Capacitor, ceramic, 0.1 μ F, 50 V, 10%, X7R	muRata
C34		Open	
C35	GRM42-6Y5V105Z025A	Capacitor, ceramic, 1 μ F, 25 V, +80%-20%, Y5V	muRata
C36	GRM42-6X7R104K050A	Capacitor, ceramic, 0.1 μ F, 50 V, 10%, X7R	muRata
C37	4SP820M	Capacitor, OS-Con, 820 μ F, 4 V, 20%	Sanyo
C38	4SP820M	Capacitor, OS-Con, 820 μ F, 4 V, 20%	Sanyo
C39	GRM235Y5V106Z016A	Capacitor, ceramic, 10 μ F, 16 V, Y5V	TDK
C40	GRM235Y5V106Z016A	Capacitor, ceramic, 10 μ F, 16 V, Y5V	TDK
C41	GRM42-6X7R104K050A	Capacitor, ceramic, 0.1 μ F, 50 V, 10%, X7R	muRata
C42	16SA470M	Capacitor, Os-Con, 470 μ F, 16 V, 20%	Sanyo
C43	GRM42-6Y5V105Z025A	Capacitor, ceramic, 1 μ F, 25 V, +80%-20%, Y5V	muRata
C44	GRM42-6X7R104K050A	Capacitor, ceramic, 0.1 μ F, 50 V, 10%, X7R	muRata
D1	SML-LX2832GC-TR	Diode. LED, green, 2.1 V, SM	Lumex
J1	MKDS3/2-5.08	Terminal block, 2-Pin, 32A, 5.08 mm	Phoenix
J2	MKDS3/2-5.08	Terminal block, 2-Pin, 32A, 5.08 mm	Phoenix
J3	ED1516-ND	Terminal block, 4-Pin, 6A, 3.5 mm	OST
J4	ED1514-ND	Terminal block, 2-Pin, 6A, 3.5 mm	OST
L1		Inductor, filter, 1.15 μ H, 11 A (8T #18 on T44-8/90 Core)	MicroMetals
L2	P1605	Inductor, filter, 1 μ H	Pulse Engineering
P1	929836-09-36-ND	Header, straight, 2x6, 0.1" (72-pin cut down)	3M
P2	A19350-ND	Header, straight, 1x2, 0.1" center	AMP
Q1†	IRF7811	FET, N-ch, 30-V, 13-A, 11-m Ω	IR
Q2	IRF7811	FET, N-ch, 30-V, 13-A, 11-milliohm	IR
Q3	IRF7811	FET, N-ch, 30-V, 13-A, 11-m Ω	IR
Q4	IRF7811	FET, N-ch, 30-V, 13-A, 11-m Ω	IR
Q5	IRF7811	FET, N-ch, 30-V, 13-A, 11-m Ω	IR
Q6	IRF7811	FET, N-ch, 30-V, 13-A, 11-m Ω	IR
Q7	2N7002	FET, N-ch, 60-V, 115-mA, 1.2- Ω	Diodes, Inc.
Q8	ND50605	FET, N-ch, -60-V, 180-mA, 5- Ω	Fairchild
Q9	IRF7811	FET, N-ch, 30-V, 13-A, 11-m Ω	IR

† Q1, R1 not installed.

Table 4–1. SLVP126 Bill of Materials (Continued)

Ref Des	Part Number	Description	MFG
R1†	Std	Resistor, chip, 0 Ω , 1/10 W, 5%	
R2	Std	Resistor, chip, 0 Ω , 1/10 W, 5%	
R3	Std	Resistor, chip, 0 Ω , 1/10 W, 5%	
R4	Std	Resistor, chip, 3.3 Ω , 1/10 W, 5%	
R5	Std	Resistor, chip, 3.3 Ω , 1/10 W, 5%	
R6	Std	Resistor, chip, 3.3 Ω , 1/10 W, 5%	
R7	Std	Resistor, chip, 2.7 Ω , 1/8 W, 5%	
R8	Std	Resistor, chip, 5.11 k Ω , 1/10 W, 1%	
R9	Std	Resistor, chip, 1.00 k Ω , 1/10 W, 1%	
R10	Std	Resistor, chip, 7.50 k Ω , 1/10 W, 1%	
R11	Std	Resistor, chip, 1.00 k Ω , 1/10 W, 1%	
R12	Std	Resistor, chip, 150 Ω , 1/10 W, 1%	
R13	Std	Resistor, chip, 51.1 Ω , 1/10 W, 1%	
R14	Std	Resistor, chip, 20 k Ω , 1/10 W, 1%	
R15	Std	Resistor, chip, 10 k Ω , 1/10 W, 1%	
R16	Std	Resistor, chip, 100 Ω , 1/10 W, 5%	
R17	Std	Resistor, chip, 1.00 k Ω , 1/10 W, 1%	
R18	Std	Resistor, chip, 1.00 k Ω , 1/10 W, 1%	
R19	Std	Resistor, chip, 2 k Ω , 1/10 W, 5%	
R20	Std	Resistor, chip, 3.3 Ω , 1/10 W, 5%	
R21	Std	Resistor, chip, 0 Ω , 1/10 W, 5%	
R24	Std	Resistor, chip, 10 k Ω , 1/10 W, 1%	
TP1-9, 12, 14-18	240-345	Test point, red	Farnell
TP10,11, 19,20	240-333	Test point, black	Farnell
TP13	131-4244-00	Adaptor, 3.5-mm probe clip (or 131-5031-00)	Tektronix
FB Loop	8021	Wire, bare, solid, 22AWG	Belden
U1	TPS5210DW	IC, PWM ripple controller, adjustable output	TI
Current Jumper	9912	Wire, PVC, stranded, 12AWG, 600 V, 105°C	Belden
NA	929950-00-ND	Shunt, jumper, 0.1" (for P1)	3M
NA	SLVP119	PCB, TPS5210 EVM board	

† Q1, R1 not installed.

Test Results



This chapter contains test results from the SLVP126 EVM.

Topic	Page
5.1 Test Summary	5-2

5.1 Test Summary

Figures 5–1 to 5–8 show the detailed test results and waveforms for the SLVP126. The following are summarized results.

5.1.1 Test Conditions

The SLVP126 EVM was tested under the following conditions:

Input voltage range:	11.4 V – 12.6 V
Output current range:	0 A – 45 A
Ambient conditions:	Room temperature with Silver Box power-supply-fan forced air cooling.

The EVM was set up for testing per Figure 3–3 of this user’s guide.

5.1.2 Static Line and Load Regulation

The precise reference voltage regulator in the TPS5210 controller uses positive and negative remote sense pins, and provides excellent regulation characteristics. The load regulation from no load to 45-A load current is less than 0.28%. The line regulation is less than 0.05% for the input voltage range from 11.4 V to 12.6 V. The initial output voltage setting is 2.0285 V, which is 1.45% higher than the nominal 2.000 V because of the active droop compensation circuit.

5.1.3 Output Voltage Ripple

The output voltage peak-to-peak ripple is less than $\pm 1\%$. This is a typical value but it can be optimized for lower ripple applications. Figure 5–5 shows measured output ripple waveforms.

The output filter for this EVM design is optimized for fast transient response due to the high slew-rate load current transitions. Therefore, the output filter is not optimized for low ripple and has a moderate amount of output ripple.

5.1.4 Efficiency and Power Losses

The following table shows efficiency and power losses for 5-V input voltage, and a maximum 40-A output current:

Evaluation Board	Efficiency, %	Power Losses, W
SLVP126, 2 V	86.7	12.5

Figure 5–2 shows efficiency graphs versus load at different line voltages.

Low power loss in components decreases their temperature rise and improves long term reliability. The EVM does not require forced air cooling at room temperature up to a load current of 30 amps.

5.1.5 Output Start-Up and Overshoot

Figure 5–6 shows start-up by applying 12 V while the 5-V enable signal is available. Figure 5–7 shows start-up by applying the 5-V enable signal while the 12-V input power is available. The figures show that the overshoot during start-up never exceeds 2.1%.

Output voltage rise time does not depend on the load current, and ramps up in a linear fashion. In this application, output voltage rise time is set to approximately 10 mS with an external capacitor.

5.1.6 Frequency Variation

The switching frequency for a hysteretic controller depends on the input and output voltages and the output filter characteristics. It has approximately the same frequency variation as constant off time controllers. The precise equation for the switching frequency, confirmed by experiment, is presented in TI's application report *Designing Fast Response Synchronous Buck Converters Using the TPS5210* (literature number SLVA044), and in the paper, presented at HFPC–98, *A Fast, Efficient Synchronous-Buck Controller for Microprocessor Power Supplies*, that can be found at the URL <http://www.ti.com/sc/docs/msp/papers/index.htm>.

Figure 5–4 shows the frequency variation over all input voltage and output current combinations, and ranges from 155 kHz to 177 kHz.

5.1.7 Load Current Transient Response

The hysteretic controller has excellent dynamic characteristics (see Figure 5–8) and does not require any feedback compensation circuitry. The load current transient response characteristics depend not only on the controller, but also on how close the converter is located to the load, the connector, the stray inductance and resistance of the output voltage traces, and high frequency decoupling. A TI-designed voltage regulation module (VRM) based on the TPS5210 controller, p/n TPS5210EVM-116, meets the requirements of the Intel VRM rev. 8.3 specification. TI has also designed a dedicated load transient test board corresponding to the motherboard model specified by Intel in the same specification. The load current transient test waveforms obtained by using the load transient test board are shown in Figure 5–8 to illustrate the controller's dynamic characteristics. The controller responds to a load transient in the same switching cycle that the transient occurs. It is important to optimize the output filter to meet the high slew rate load current transient requirements, and to minimize cost by decreasing the number of expensive bulk capacitors. Special attention must be paid to high frequency decoupling to decrease the initial transient spike to an acceptable level, because it is not dependent on the controller characteristics.

5.1.8 Features

The EVM has all the features, which are described in detail in the datasheet for the TPS5210 controller.

The features include undervoltage lockout for both 12-V and 5-V input, inhibit signal, power good signal, overvoltage protection, slow start, remote sense, and overcurrent protection. Overcurrent limit is set to approximately 46 A.

5.1.9 Test Data

The following graphs and oscilloscope waveforms show the main performance characteristics of the SLVP126 EVM.

Figure 5–1. SLVP126 Measured Line and Load Regulation

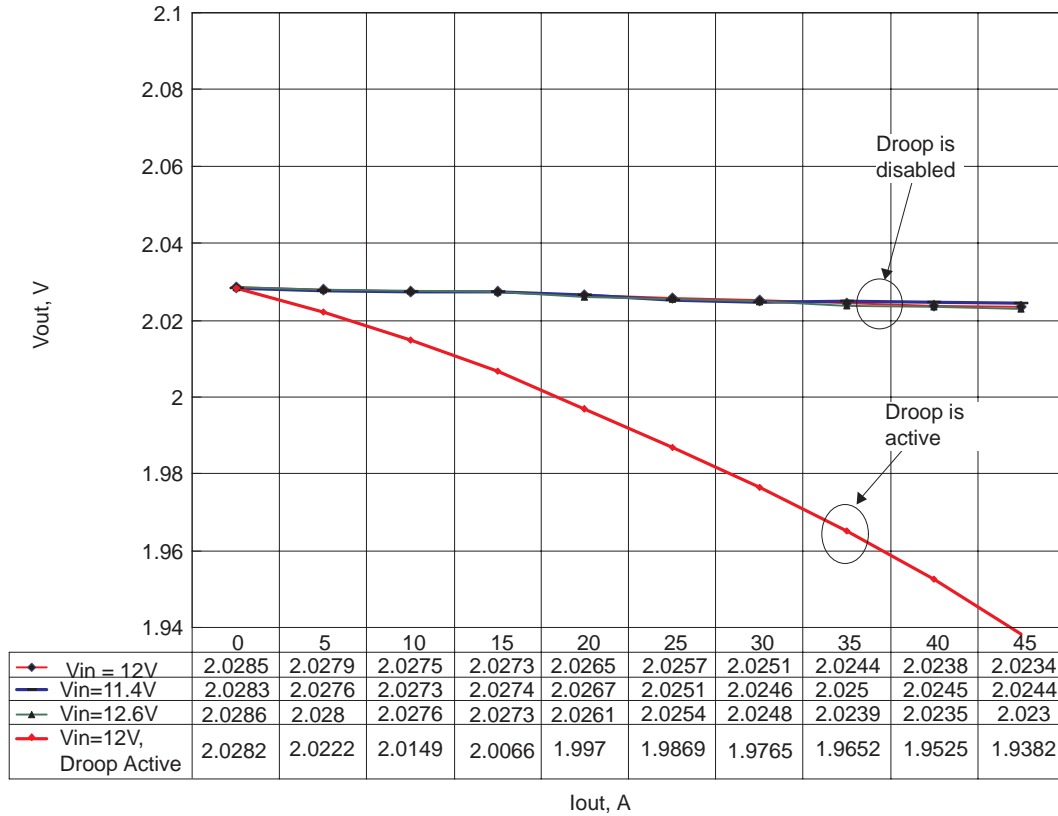

Figure 5–2. SLVP126 Measured Efficiency

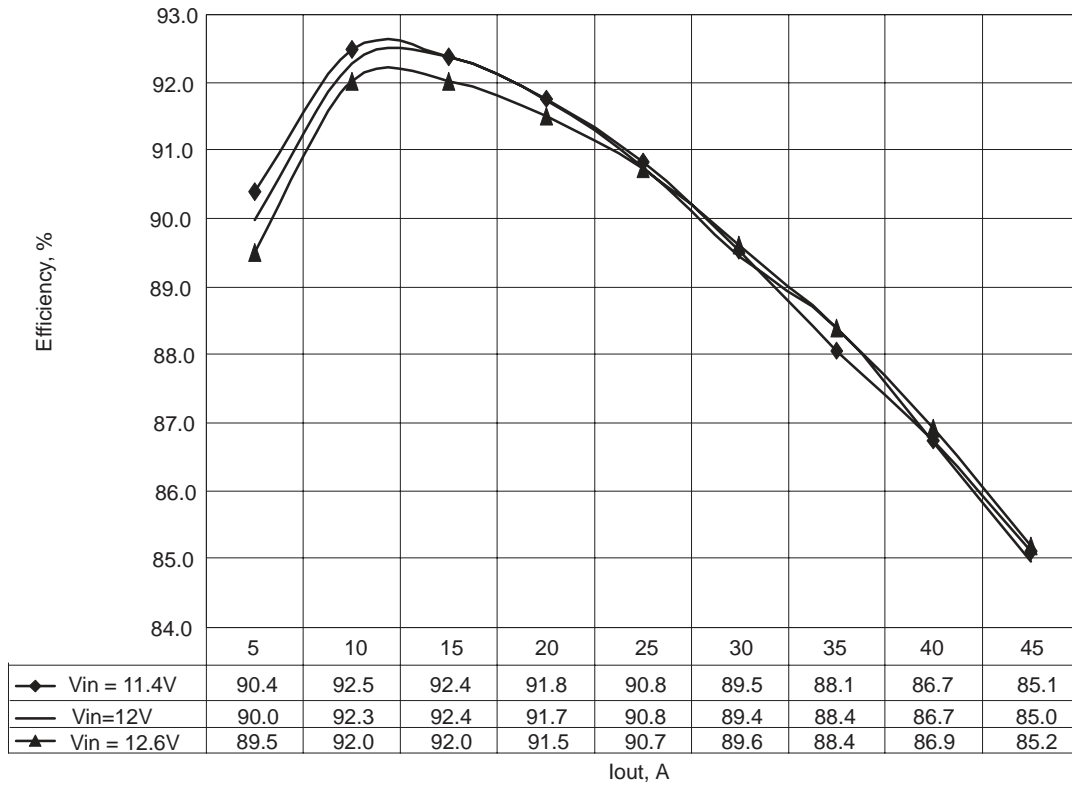

Figure 5–3. SLVP126 Measured Power Dissipation

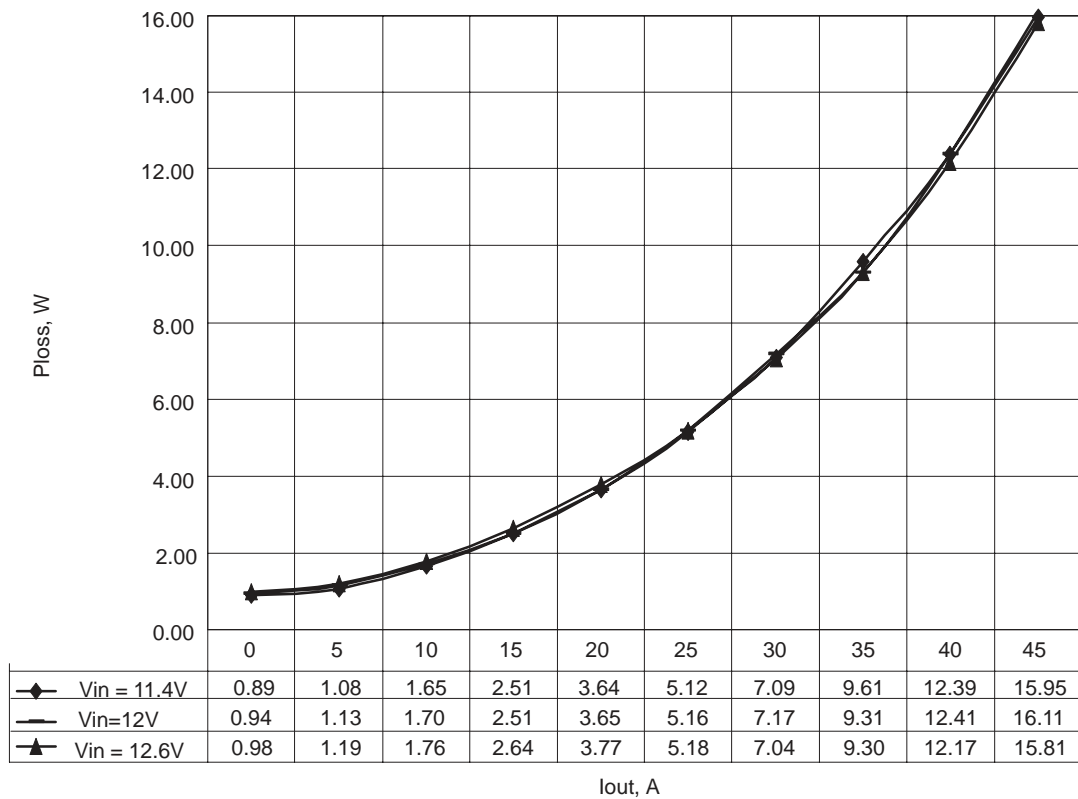

Figure 5–4. SLVP126 Measured Switching Frequency

For Figure 5–4, the output voltage is set to 2 V by VID inputs.

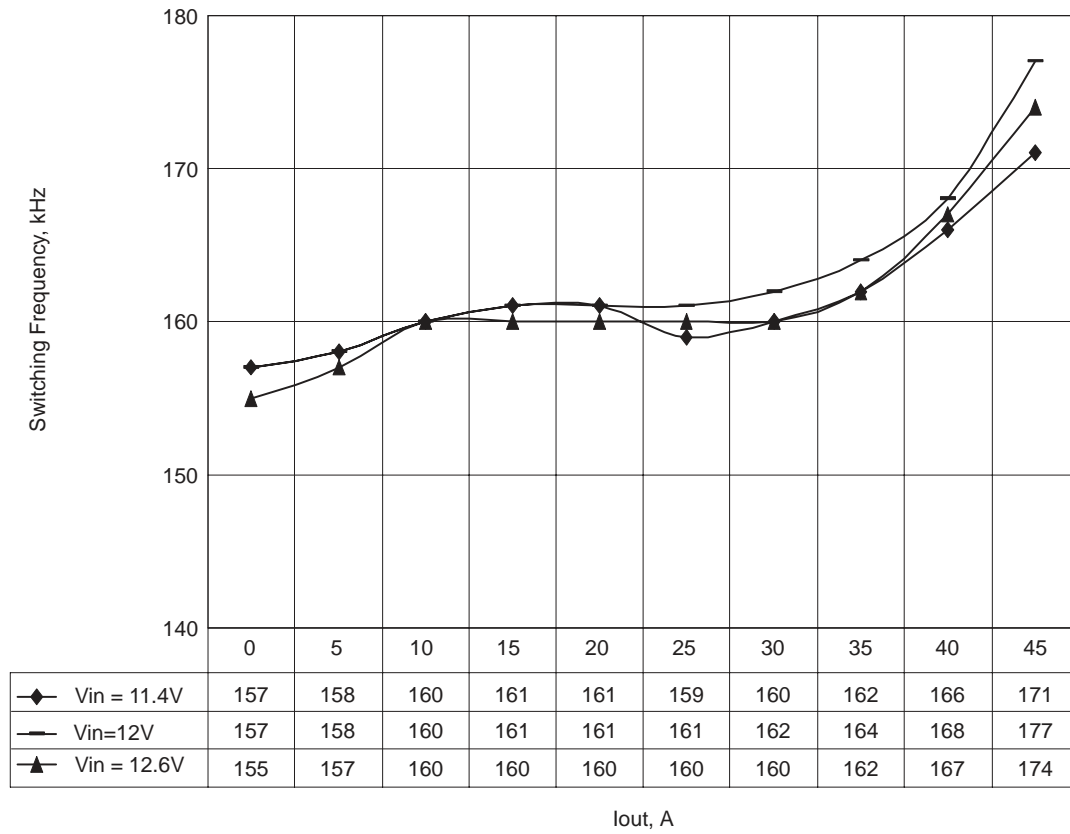

Figure 5-5. SLVP126 Measured Switching Waveforms

For Figure 5-5, the input voltage is set to 12 V and I_O is set to 40 A.

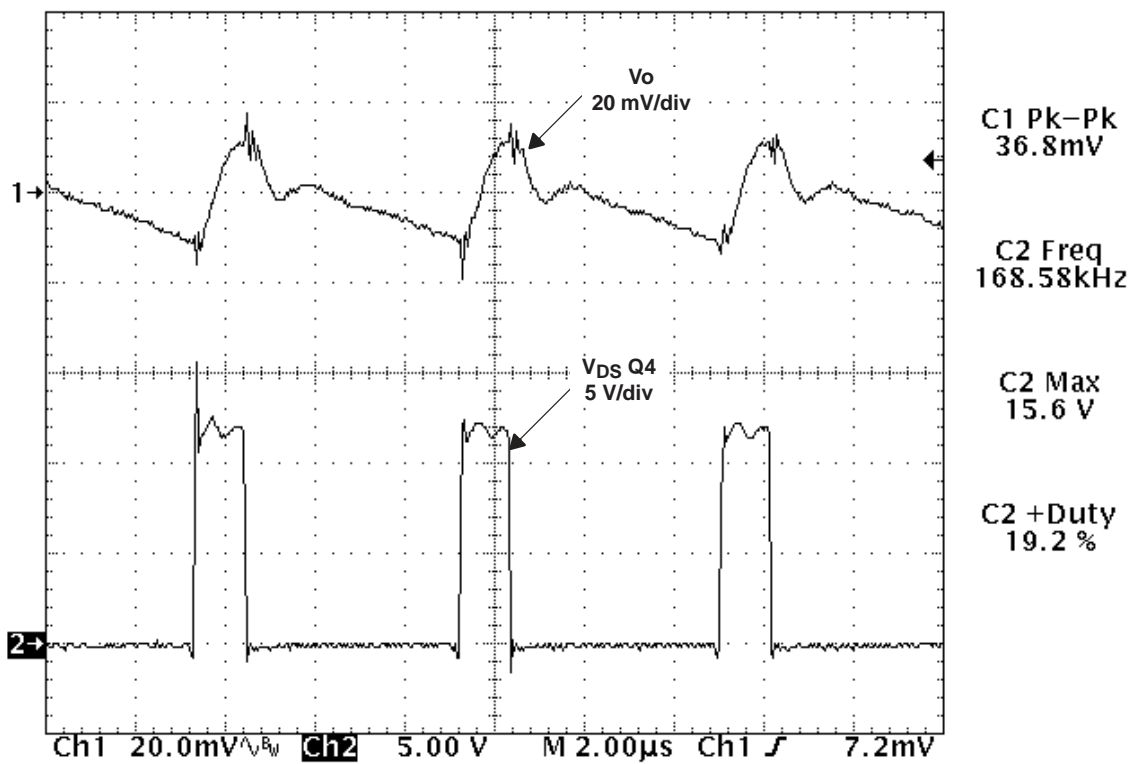

Figure 5–6. SLVP126 Measured Start-Up (V_{CC}) Waveforms

For Figure 5–6, 12-V input is applied with enable signal already present.

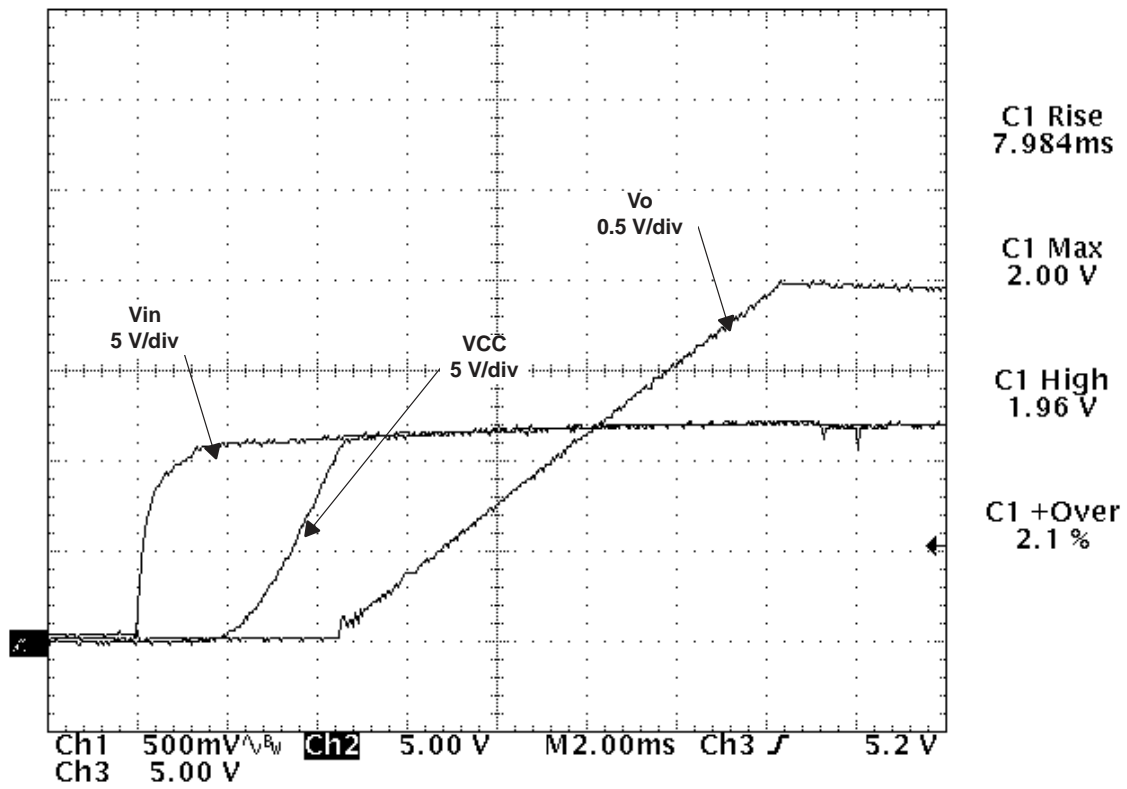

Figure 5-7. SLVP126 Measured Start-Up (Enable) Waveforms

For Figure 5-7, enable signal is applied with 12-V input already present.

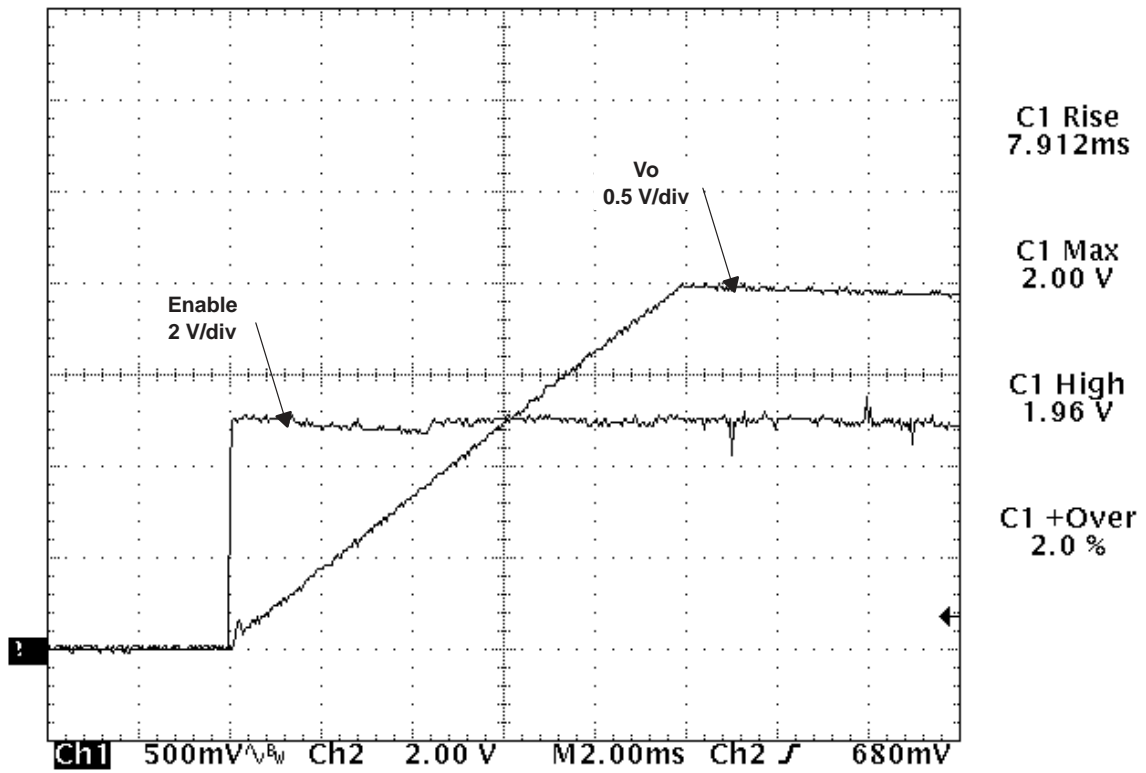
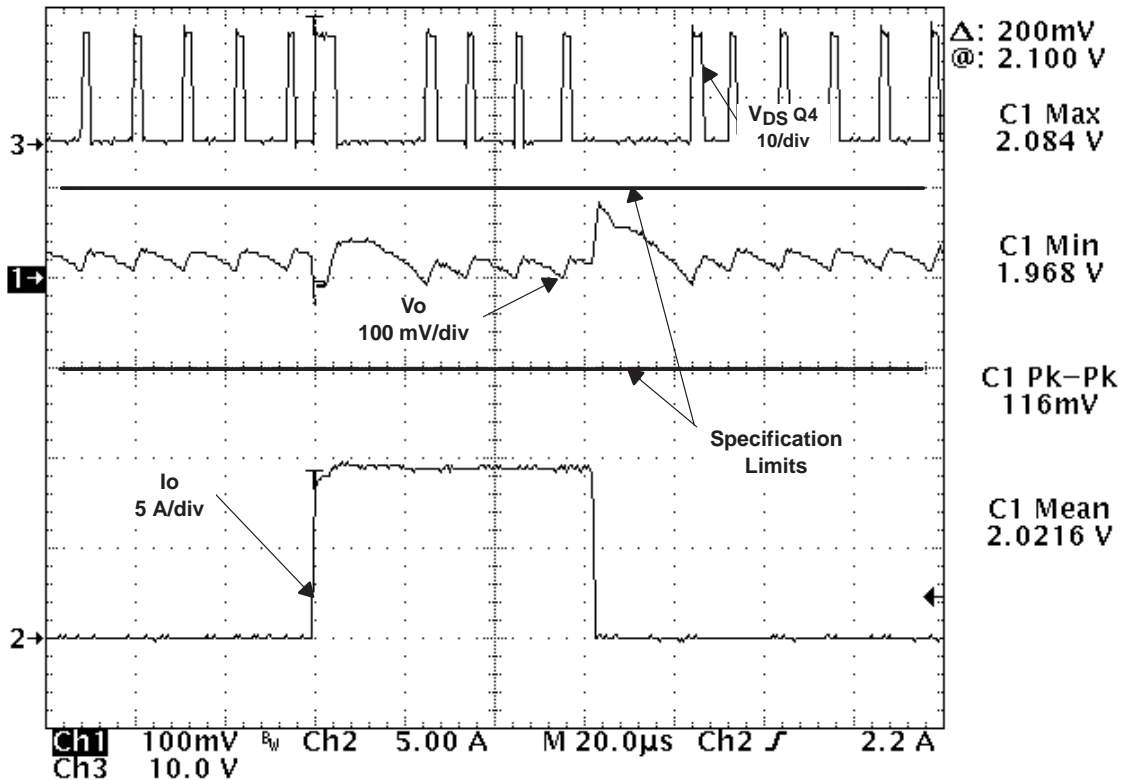

Figure 5–8. SLVP126 Measured Load Transient Response

For Figure 5–8, the output voltage transient response from a 10-A load current step with slew rate $20 \text{ A}/\mu\text{S}$, is measured on SLVP116 (VRM 8.3) and TI's transient tester SLVP123 in accordance with Intel's requirements. The specification limits for this test: are $2.000 \pm 0.100 \text{ V}$.



5.1.10 Conclusion

Test results for the SLVP126 EVM demonstrate the advantages of TPS5210 controllers in meeting stringent power supply requirements, especially for DSPs and microprocessors. The power system designer now has a good solution to optimize his particular application. Detailed information on how to design dc-dc converters using the TPS5210 controller is presented in TI's application report, *Designing Fast Response Synchronous Buck Regulators Using the TPS5210*, literature number SLVA044.