

### FEATURES

**Input voltage range: 4 V to 28 V**

**Output current range: 0 mA to 50 mA**

**Output voltage accuracy:  $\pm 1\%$**

**Operating temperature range:  $-40^{\circ}\text{C}$  to  $+125^{\circ}\text{C}$**

### GENERAL DESCRIPTION

The ADP1720 evaluation board can be used to demonstrate the functionality of the ADP1720 linear regulator. Depending on what component combinations are used, the evaluation board can be used for ADP1720 fixed output voltage devices and ADP1720 adjustable output voltage devices.

Simple device measurements such as line and load regulation, dropout, and ground current can be demonstrated with just a single voltage supply, a voltage meter, a current meter, and load resistors.

For more details about the ADP1720 linear regulators, visit [www.analog.com](http://www.analog.com).

### EVALUATION BOARD

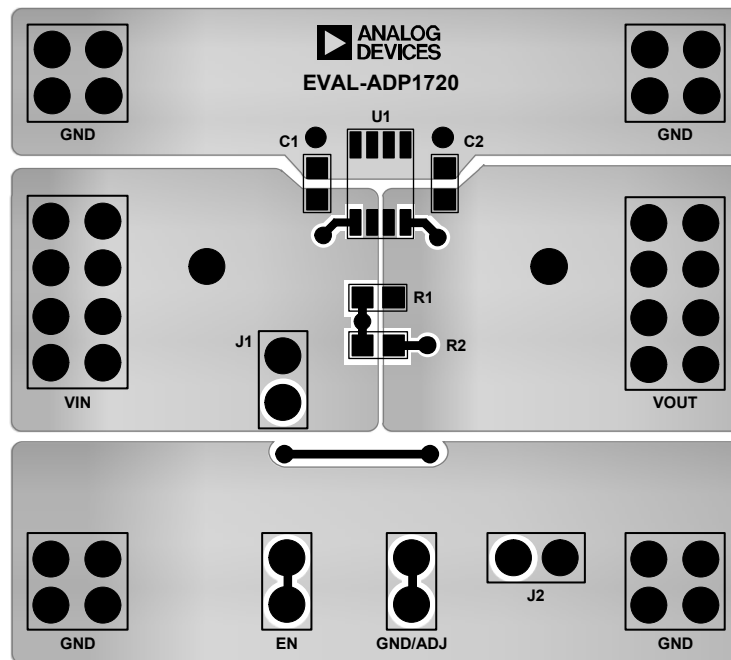

Figure 1.

### Rev. 0

Evaluation boards are only intended for device evaluation and not for production purposes. Evaluation boards are supplied "as is" and without warranties of any kind, express, implied, or statutory including, but not limited to, any implied warranty of merchantability or fitness for a particular purpose. No license is granted by implication or otherwise under any patents or other intellectual property by application or use of evaluation boards. Information furnished by Analog Devices is believed to be accurate and reliable. However, no responsibility is assumed by Analog Devices for its use, nor for any infringements of patents or other rights of third parties that may result from its use. Analog Devices reserves the right to change devices or specifications at any time without notice. Trademarks and registered trademarks are the property of their respective owners. Evaluation boards are not authorized to be used in life support devices or systems.

## TABLE OF CONTENTS

Features .....	1	Load Regulation .....	6
General Description .....	1	Dropout Voltage .....	6
Evaluation Board .....	1	Ground Current Measurements .....	7
Revision History .....	2	Ground Current Consumption .....	7
Evaluation Board Hardware and Schematic .....	3	Ordering Information .....	8
Evaluation Board Configurations .....	4	Bill of Materials .....	8
ADP1720 Adjustable Output .....	4	Ordering Guide .....	8
ADP1720 Fixed Output .....	4	ESD Caution .....	8
Output Voltage Measurements .....	5		
Line Regulation .....	5		

## REVISION HISTORY

6/07—Revision 0: Initial Version

## EVALUATION BOARD HARDWARE AND SCHEMATIC

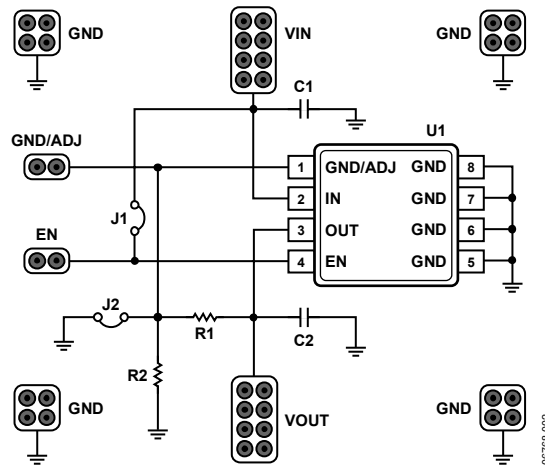

Figure 2. Evaluation Board Schematic

Table 1. Evaluation Board Hardware Components

Component	Function	Description
U1 <sup>1</sup>	Linear regulator	ADP1720 Low Dropout Linear Regulator.
C1	Input capacitor	1 $\mu$ F Input Bypass Capacitor.
C2	Output capacitor	1 $\mu$ F Output Capacitor. Required for stability and transient performance.
R1, R2 <sup>2</sup>	Output voltage adjust resistors	External Resistors. Used to set VOUT with the adjustable version of ADP1720.
J1	Jumper	Jumper. Connects EN to VIN for automatic startup.
J2 <sup>3</sup>	Jumper	Jumper. Connects the GND/ADJ pin to GND for fixed version devices.

<sup>1</sup> Component varies depending on which evaluation board type is ordered.

<sup>2</sup> Components present only on boards with ADP1720 adjustable output devices.

<sup>3</sup> Components present only on boards with ADP1720 fixed output devices.

# EVAL-ADP1720

## EVALUATION BOARD CONFIGURATIONS

The ADP1720 evaluation boards come supplied with different components depending on which version is ordered.

Components common to all versions are C1, C2, and J1.

### ADP1720 ADJUSTABLE OUTPUT

Evaluation boards that come supplied with ADP1720 adjustable output voltage option devices have the additional R1 and R2 resistors included. Figure 3 shows the schematic of this evaluation board configuration.

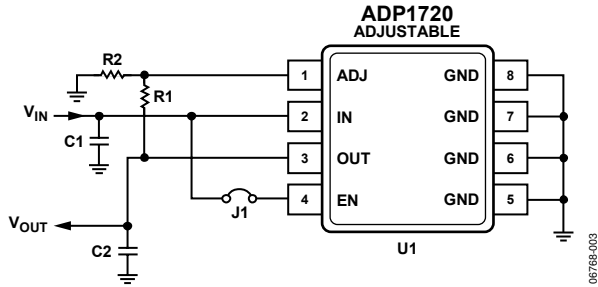

Figure 3. ADP1720 Adjustable Output

The output voltage is set based on the following equation:

$$V_{OUT} = 1.225 \text{ V} (1 + R1/R2)$$

For example, if R1 = 15 kΩ and R2 = 10 kΩ, then V<sub>OUT</sub> is 3.06 V.

### ADP1720 FIXED OUTPUT

Fixed output voltage evaluation boards are available in 3.3 V and 5 V options. For fixed output devices, J2 is inserted to connect the GND/ADJ pin to ground. Figure 4 shows the schematic of this evaluation board configuration.

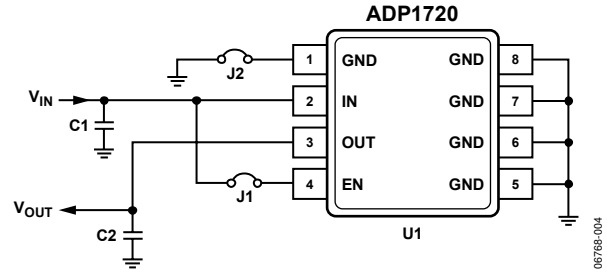

Figure 4. ADP1720 Fixed Output

## OUTPUT VOLTAGE MEASUREMENTS

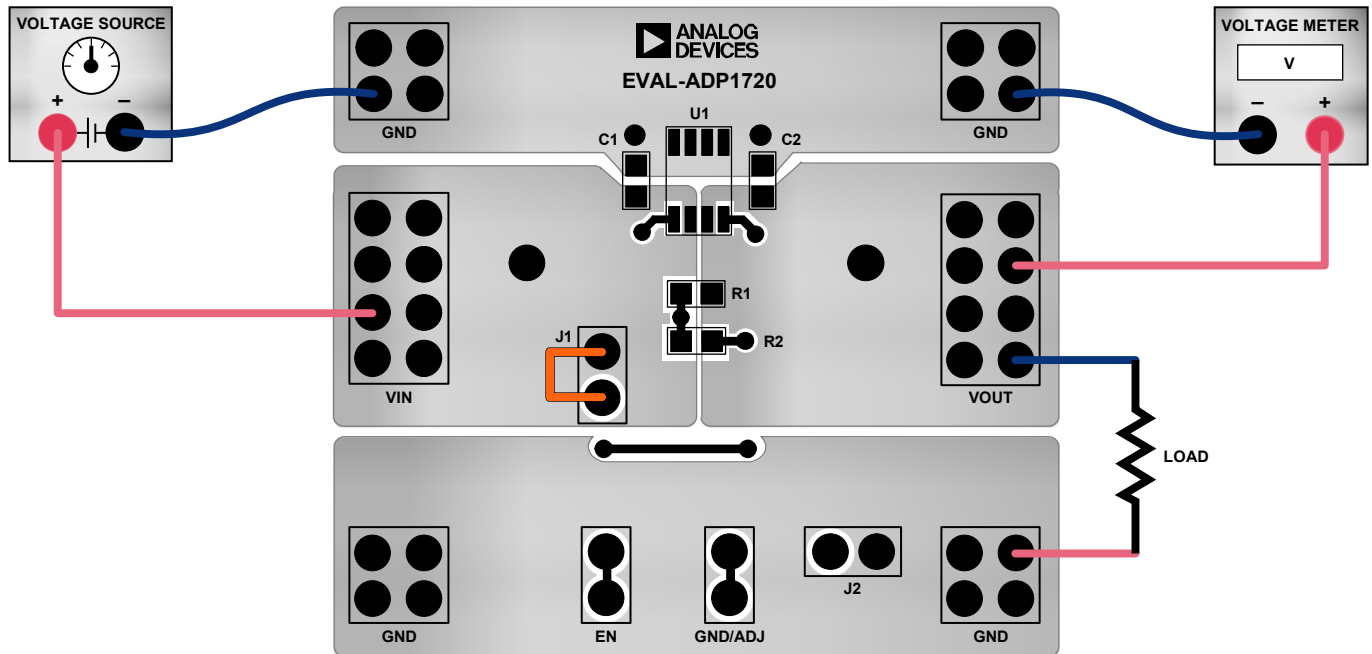

Figure 5.

Figure 5 shows how the evaluation board can be connected to a voltage source and a voltage meter for some basic output voltage accuracy measurements. A resistor can be used as the load for the regulator. Ensure the resistor has a power rating adequate to handle the power expected to be dissipated across it. An electronic load can be used as an alternative. Ensure the voltage source used can supply adequate current for the expected load levels.

Follow these steps to connect to a voltage source and voltage meter:

1. Connect the negative terminal (–) of the voltage source to one of the GND pads on the evaluation board.
2. Connect the positive terminal (+) of the voltage source to the VIN pad of the evaluation board.
3. Connect a load between the VOUT pad and one of the GND pads.
4. Connect the negative terminal (–) of the voltage meter to one of the GND pads, and the positive terminal (+) of the voltage meter to the VOUT pad.
5. The voltage source can now be turned on. If J1 is inserted (this connects EN to VIN for automatic startup), then the regulator powers up.

If large load currents are used, then the user must connect the voltage meter as close as possible to the output capacitor to reduce the effects of IR drops.

## LINE REGULATION

For line regulation measurements, the regulator's output is monitored while its input is varied. For good line regulation, the output must change as little as possible with varying input levels. To ensure the device is not in dropout during this measurement,  $V_{IN}$  must be varied between  $V_{OUT_{NOM}} + 0.5\text{ V}$  (or 4 V, whichever is greater) to  $V_{IN_{MAX}}$ . For an ADP1720 with 5 V output, this means  $V_{IN}$  needs to be varied between 5.5 V and 28 V. This measurement can be repeated under different load conditions. Figure 6 shows the typical line regulation performance of an ADP1720 with 5 V output.

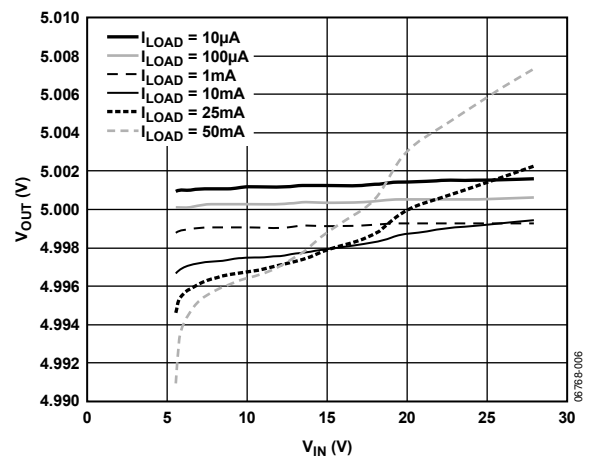

Figure 6. ADP1720 Line Regulation

# EVAL-ADP1720

## LOAD REGULATION

For load regulation measurements, the regulator's output is monitored while the load is varied. For good load regulation, the output must change as little as possible with varying load levels. The input voltage must be held constant during this measurement. The load current can be varied from 0 mA to 50 mA. Figure 7 shows the typical load regulation performance of an ADP1720 with 5 V output for an input voltage of 12 V.

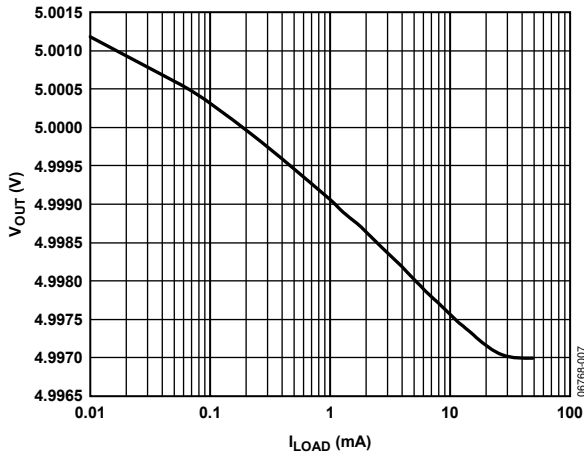

Figure 7. ADP1720 Load Regulation

## DROPOUT VOLTAGE

Dropout voltage measurements can also be performed using the configuration shown in Figure 5. Dropout voltage is defined as the input-to-output voltage differential when the input voltage is set to the nominal output voltage. This applies only for output voltages above 4 V. Dropout voltage increases with larger loads. For more accurate measurements, a second voltage meter can be used to monitor the input voltage across the input capacitor. The input supply voltage may need to be adjusted to account for IR drops, especially if large load currents are used. Figure 8 shows a typical curve of dropout voltage measurements with different load currents.

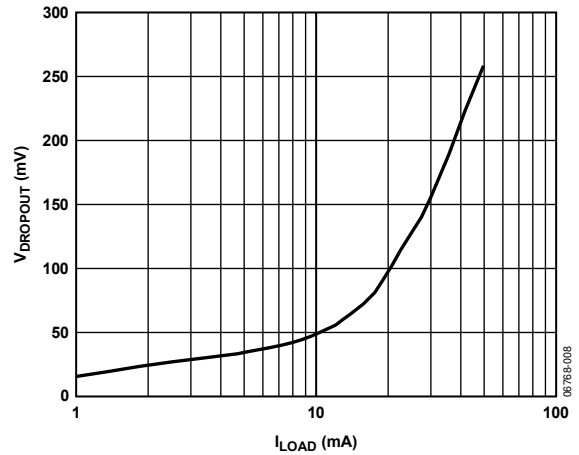

Figure 8. Dropout Voltage vs. Load Current

## GROUND CURRENT MEASUREMENTS

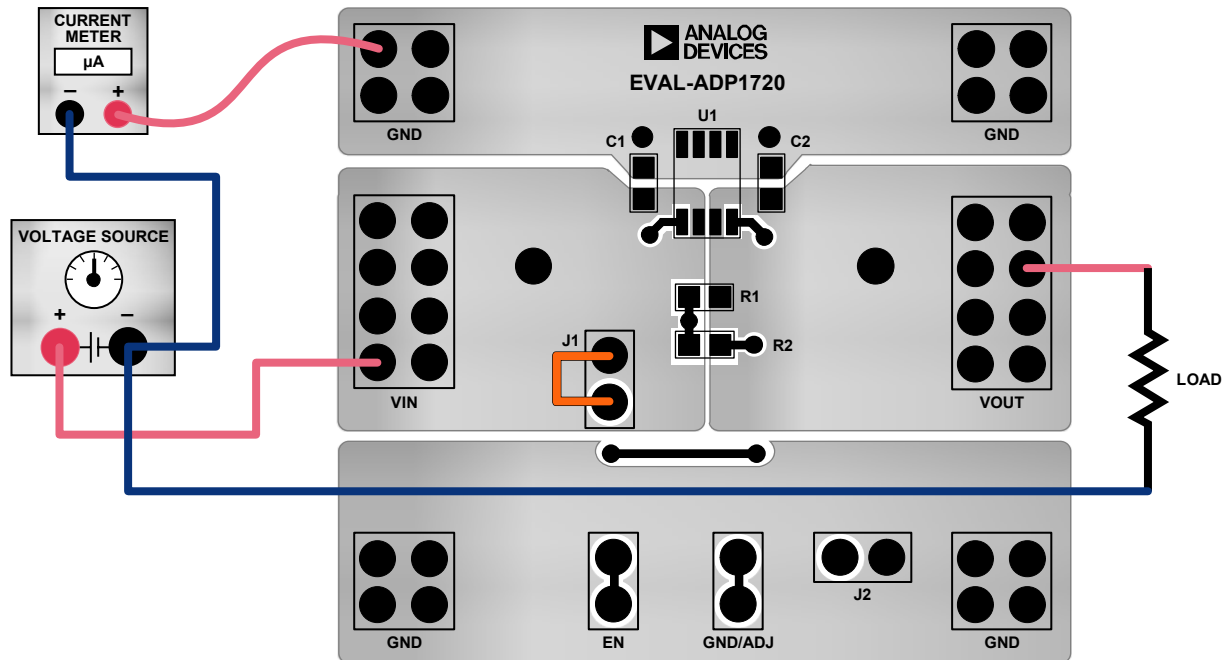

Figure 9.

06786-010

Figure 9 shows how the evaluation board can be connected to a voltage source and a current meter for ground current measurements. A resistor can be used as the load for the regulator. Ensure the resistor has a power rating adequate to handle the power expected to be dissipated across it. An electronic load can be used as an alternative. Ensure the voltage source used can supply adequate current for the expected load levels.

Follow these steps to connect to a voltage source and current meter:

1. Connect the positive terminal (+) of the voltage source to the VIN pad on the evaluation board.
2. Connect the positive terminal (+) of the current meter to one of the GND pads of the evaluation board.
3. Connect the negative terminal (-) of the current meter to the negative (-) terminal of the voltage source.
4. Connect a load between the VOUT pad of the evaluation board and the negative (-) terminal of the voltage source.
5. The voltage source can now be turned on. If J1 is inserted (this connects EN to VIN for automatic startup), then the regulator powers up.

### GROUND CURRENT CONSUMPTION

Ground current measurements are a way of determining how much current the regulator's internal circuits are consuming, while performing the regulation function. To be efficient, the regulator must consume as little current as possible. Typically, the regulator consumes maximum current when supplying its

largest load level (50 mA). Figure 10 shows the typical ground current consumption for various load levels.

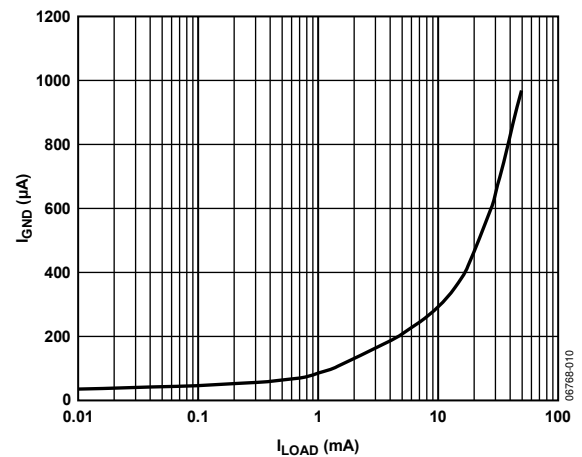

Figure 10. Ground Current vs. Load Current

When the device is disabled (EN = 0 V), ground current is reduced to less than 1 µA.

Note that larger ground current levels are observed when using an evaluation board with R1 and R2 present.

# EVAL-ADP1720

## ORDERING INFORMATION

### BILL OF MATERIALS

Table 2.

Qty	Reference Designator	Description	Manufacturer/Vendor	Vendor Part No.
1	C1	Capacitor, MLCC, 1 $\mu$ F, 50 V, 0805, X7R	Murata or equivalent	GRM21BR71H105KA12
1	C2	Capacitor, MLCC, 1 $\mu$ F, 16 V, 0805, X7R	Murata or equivalent	GRM21BR71C105KA01
1	R1	Resistor, 15 k $\Omega$ , 1%, 0805	Vishay Dale or equivalent	CRCW080515K0FKEA
1	R2	Resistor, 10 k $\Omega$ , 1%, 0805	Vishay Dale or equivalent	CRCW080510K0FKEA
2	J1, J2	Header, single, STR, 2 pins	Digi-Key, Corp.	S1012E-36-ND
1	U1	ADP1720, IC, LDO regulator	Analog Devices, Inc.	ADP1720ARMZ-5-R7 ADP1720ARMZ-3.3-R7 ADP1720ARMZ-R7

### ORDERING GUIDE

Model	Description
ADP1720-EVALZ <sup>1</sup>	Evaluation Board with Adjustable Output ADP1720
ADP1720-3.3-EVALZ <sup>1</sup>	Evaluation Board with 3.3 V Fixed Output ADP1720
ADP1720-5-EVALZ <sup>1</sup>	Evaluation Board with 5 V Fixed Output ADP1720

<sup>1</sup> Z = RoHS Compliant Part.

### ESD CAUTION



**ESD (electrostatic discharge) sensitive device.** Charged devices and circuit boards can discharge without detection. Although this product features patented or proprietary protection circuitry, damage may occur on devices subjected to high energy ESD. Therefore, proper ESD precautions should be taken to avoid performance degradation or loss of functionality.