



Part Number: D3C0116

Electrical Specifications

| | |
|------------------------|---------------------|
| Frequency Range (GHz): | 1.4 – 1.6 |
| Isolation (dB): | 20 MIN |
| Insertion Loss (dB): | 0.4 MAX |
| VSWR: | 1.25:1 MIN |
| Forward Power (W): | 200 AVG 2,000 PK |

Mechanical/Environmental Specifications

| | |
|-------------------|----------------------------|
| Connector Type: | SMA |
| Connector Body: | Passivated stainless steel |
| Connector Pin: | Gold plated copper |
| Load Body: | Brass |
| Magnetic Shunt: | Nickel plated CRS |
| Operational Temp: | -20°C to +65°C |
| Weight (oz) | 3.0 MAX |

D3C0116 Dimensions

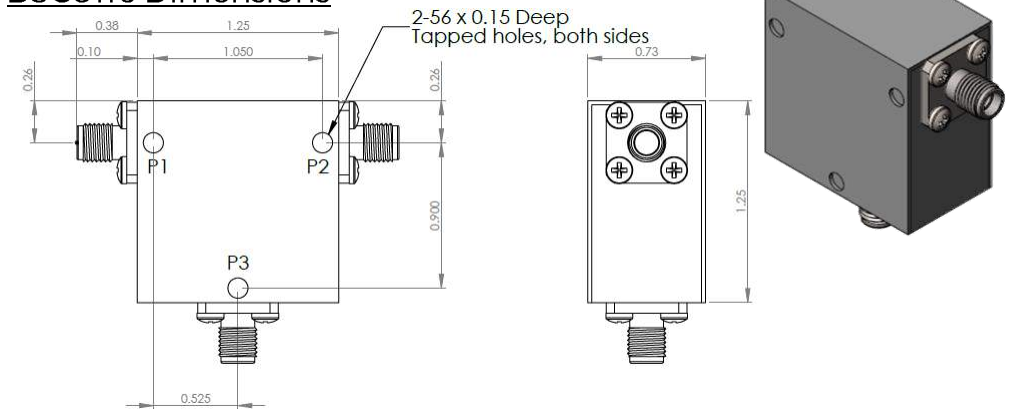

D3C0116-3 Dimensions

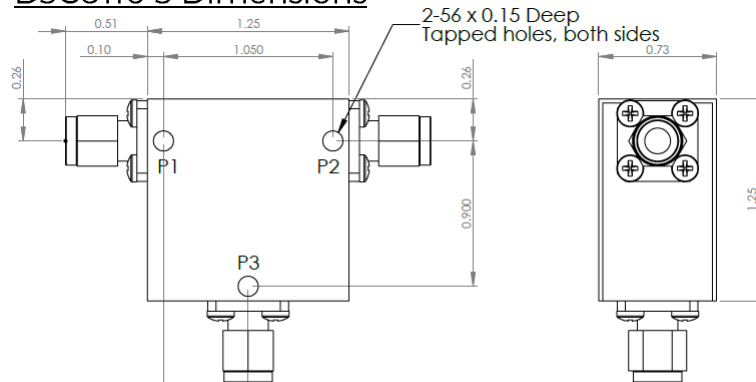

Dimensions are in inches
Tolerance
XX ±0.03
XXX ±0.010

| Type of Device | PN Suffix | Connector Configuration Input / Output | PN Example |
|---|----------------------|---|------------|
| Single Junction Circulator 3-Port Device Port 1 / Port 2 / Port 3 | No Dash | Female / Female / Female | D3C0116 |
| | -1 | Male / Female / Female | D3C0116-1 |
| | -2 | Female / Male / Female | D3C0116-2 |
| | -3 | Male / Male / Male | D3C0116-3 |
| | -4 | Female / Female / Male | D3C0116-4 |
| | -5 | Male / Female / Male | D3C0116-5 |
| | -6 | Male / Male / Female | D3C0116-6 |
| -7 | Female / Male / Male | D3C0116-7 | |



MEASURED DATA

Part Number: D3C0116, P1→P2, P3 Terminated with 50Ω, +25°C

