

REVISION(S)			
LTR	DESCRIPTION	INIT	APP'D
O	ECN: 0S60-0096-05	E.T 4/5/05	B.P 4/6/05
A	ECR-06-019279	E.T 8/9/06	V.K 8/9/06

1. MATERIAL:

HEAT SINK: ALUM. (BLACK ANODIZE)
CLIP: BLACK PEI (UL94-V0)

2. BEFORE THE HEATSINK APPLICATION, THE USER SHOULD IDENTIFY THE SPECIFICATION OF MAXIMUM LOAD ON THE BGA PACKAGE.

HEATSINK TORQUE SPECIFICATIONS CONVERTED TO FORCE.

BARE DIE PACKAGE:

1.5 POUND-FORCE INCH TORQUE = 8.5 POUND-FORCE
(0.17 NEWTON TORQUE = 37.81 NEWTON)

2.0 POUND-FORCE INCH TORQUE = 11.4 POUND-FORCE
(0.23 NEWTON METER TORQUE = 50.71NEWTON)

FULL SIZE LID PACKAGE:

1.5 POUND-FORCE INCH TORQUE = 8.3 POUND-FORCE
(0.17 NEWTON TORQUE = 36.92NEWTON)

2.0 POUND-FORCE INCH TORQUE = 11.1 POUND-FORCE
(0.23 NEWTON METER TORQUE = 49.38NEWTON)

3. REMOVE CLIP WITH REMOVAL TOOL P/N: 1542616-1.

4. RoHS COMPLIANT AND CERTIFIED.

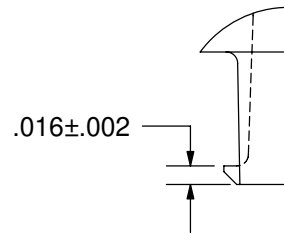
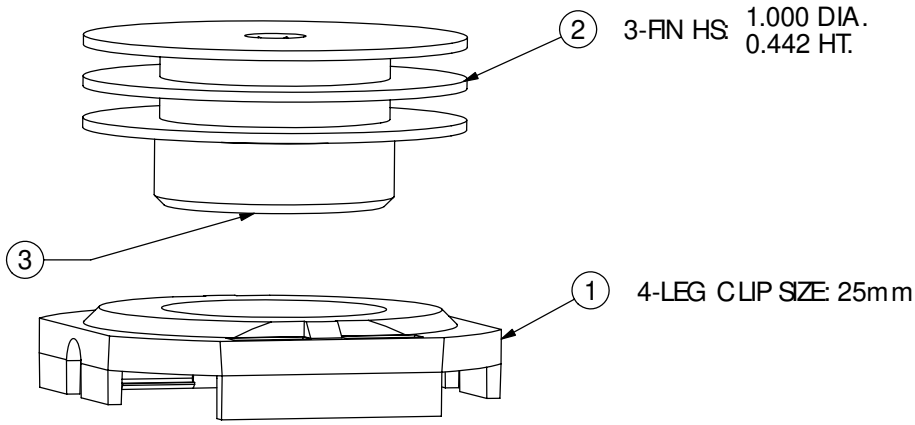

DETAIL A
SCALE = 6X

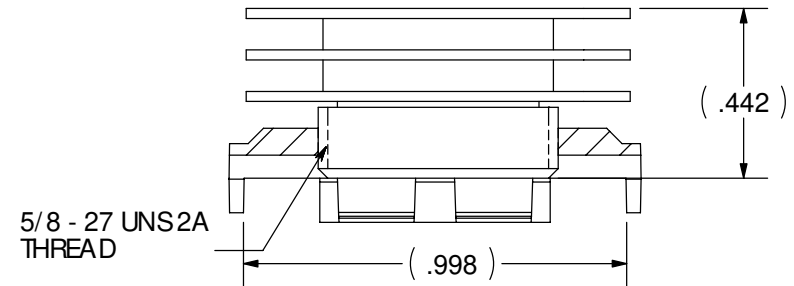
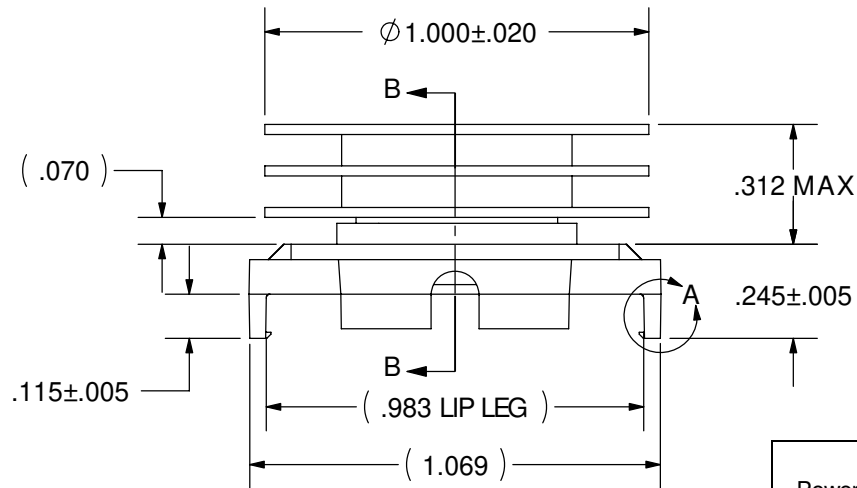

SECTION B-B

Power	° C/W @ Ambient	° C/W @ 200 LFM	° C/W @ 400 LFM	° C/W @ 600 LFM
5 Watts	14.51	8.58	5.66	4.40
10 Watts	13.61	8.76	5.68	4.40
15 Watts	12.45	8.71	5.75	4.34

CUSTOMER DRAWING

SPECIFICATIONS ARE SUBJECT TO CHANGE WITHOUT NOTICE

ITEM	DESCRIPTION	QTY	DO NOT SCALE
1	MOUNTING CLIP	1	
2	HEAT SINK	1	
3	INTERFACE	1	

tyco / Electronics Attleboro Falls Massachusetts 02763

UNLESS OTHERWISE SPECIFIED TO LEFTRANCES ARE:

DRAWN BY: ETAO	DATE: 4/4/05	MATERIAL: SEE NOTE
ENGINEER: B.PETROCELLI	DATE: 4/6/05	FINISH: SEE NOTE
FILENAME: PROJECT: SYSTEM:		

CONFIDENTIAL PROPERTY OF TYCO ELECTRONICS NOT TO BE DISCLOSED TO OTHERS REPRODUCED OR USED FOR ANY PURPOSES EXCEPT AS AUTHORIZED IN WRITING BY AN AUTHORIZED OFFICIAL OF TYCO. MUST BE RETURNED TO TYCO ON DEMAND, ON COMPLETION OF ORDERS OR OTHER PURPOSES FOR WHICH LENT.

TITLE: 25mm HEATSINK ASSEMBLY (HTS703-U)

DIMENSIONS ARE IN: INCHES	SCALE: 2:1	PART NO.: 1542004-3	SHEET: 1 OF 1
TINFD ANGLE PROJECTION	SIZE: A	DWG. NO. C-1542004-3	REV: A