

ATLANTIC VERSION TERMINATOR INTERFACE ADAPTER	PART NUMBER	REVISION	DESCRIPTION	FEED TYPE	CONVERT TO	PART NUMBERS REQUIRED					
	2150358-1	A	FINE CRIMP HEIGHT ADJUST	MECHANICAL	PNEUMATIC FEED	2119950-1	2119792-1	-	2119641-1	-	2063440-1
	2150358-2	A	FINE CRIMP HEIGHT ADJUST	PNEUMATIC	SERVO LATCH PLATE	2119951-1	1901697-1	8-2150358-5	-	-	2168400-7 (QUANTITY 2)
					SMART APPLICATOR	2161326-1	-	8-2150358-4	-	-	-
					MECHANICAL FEED	2119949-1	2063961-1	5-18022-5	2119653-1	-	-
	2150358-5	A	FINE CRIMP HEIGHT ADJUST	SERVO LATCH PLATE ⁴	SERVO LATCH PLATE	2119951-1	1901697-1	8-2150358-5	-	-	2168400-7 (QUANTITY 2)
					SMART APPLICATOR	2161326-1	-	8-2150358-4	-	-	-
					MECHANICAL FEED	2119949-1	2063961-1	5-18022-5	2119653-1	-	-
2150358-6	A	NON-CRIMP HEIGHT ADJUST	SERVO LATCH PLATE ⁴	-	-	-	-	-	-	-	
2150358-7	A	FINE CRIMP HEIGHT ADJUST	NONE	-	-	-	-	-	-	-	
7-2150358-7	A	CRIMP TOOLING KIT	-	-	-	-	-	-	-	-	

APPLICATOR DATA		
CRIMP	SIZE	TYPE
WIRE	2.54 mm [.100]	F
INSUL	3.56 mm [.140]	O
APPLICATOR INSTRUCTIONS 408-10390		

TERMINAL DATA: JUNO TERMINAL TE CRIMP SPECIFICATION			
TERMINAL NAME: RING			
WIRE STRIP LENGTH		INSULATION DIAMETER RANGE	
3.60-3.90 mm [.142-.154 IN]		∅ 2.70mm [.106 IN]	
TERMINAL APPLICATION SPECIFICATION	NONE	-	-
TERMINALS APPLIED			
TE TERMINAL	JUNO TERMINAL	TE TERMINAL	JUNO TERMINAL
2113363-1	E86000-06	2113363-2	S0107-00

WIRE SIZE	CRIMP HEIGHT mm [INCH]	CRIMP HEIGHT REFERENCE SETTING
18 AWG	1.52 +/- 0.05 [.060 +/- .002]	8.1
20 AWG	1.40 +/- 0.05 [.055 +/- .002]	9.3

- RECOMMENDED SPARE PARTS
- GREASE BEARING SURFACES LIGHTLY
- 3. LUBRICATE DAILY PER THE APPLICATOR INSTRUCTION SHEET SUPPLIED WITH THE APPLICATOR.
- APPLICATOR SPECIFIC DATA TO BE ENTERED INTO BLANK MEMORY CHIP AT ASSEMBLY. SEE BELOW FOR PART NUMBER:
 MECHANICAL FEED WITH "SMART APPLICATOR" CONVERSION: 8-2150358-4
 PNEUMATIC FEED WITH "SMART APPLICATOR" CONVERSION: 8-2150358-4
 SERVO FEED WITH "FINE CRIMP HEIGHT ADJUST": 8-2150358-5
 SERVO FEED WITH "NON-CRIMP HEIGHT ADJUST": 8-2150358-6
- 5. ADJUSTMENT OF THE STRIPPER MAY BE REQUIRED WHEN MOVING THE APPLICATOR BETWEEN BENCH AND LEADMAKER APPLICATIONS.
- APPLY PART NUMBER 1-23419-5 LOCTITE TO THREADS OF ITEMS 62 & 242. FOR -6 ONLY APPLY PART NUMBER 1-23419-5 LOCTITE TO THREADS OF ITEMS 37 & 242.
- GREASE THREADS, GROOVE AND O-RING ON ITEMS 35 & 252.
- MAGNET, ITEM 166 MUST BE ORIENTED CORRECTLY IN ORDER TO PROPERLY ACTUATE THE COUNTER.
- CRIMP HEIGHT REFERENCE SETTING WAS THE SETTING USED WHEN THE APPLICATOR WAS QUALIFIED AT THE FACTORY. ADJUSTMENT MAY BE NECESSARY WHEN RUNNING APPLICATOR IN THE FIELD.
- SPARE FEED CAM STORAGE LOCATION REFER TO INSTRUCTION SHEET FOR ADDITIONAL INFORMATION.
- THE RECOMMENDED SET-UP FOR END FEED APPLICATORS IS POST-FEED WITH ITEM 2119653-1. THE APPLICATOR CAN BE CONFIGURED FOR PRE-FEED WITH ITEM 2119652-1 BUT MAY ENCOUNTER PROBLEMS WITH SOME APPLICATIONS. FEED ISSUES OR TERMINAL JAMMING MAY OCCUR IN THE PRE-FEED CONFIGURATION.
- WHEN ASSEMBLING -6 NON-CRIMP HEIGHT ADJUST APPLICATOR USE SHIM PACK 2119957-2 TO ALIGN APPLICATOR'S MAXIMUM WIRE CRIMP HEIGHT AT NORMAL TERMINATOR SHUT HEIGHT

***WARNING**
 ON INSTALLATION, SET WIRE DISC, ITEM 40 TO LARGEST WIRE SIZE SETTING. USE OF SETTINGS BELOW MINIMUM REQUIRED CRIMP HEIGHT SETTING WILL CAUSE DAMAGE TO CRIMP TOOLING.

ATLANTIC VERSION
 Shown on sheets 1 of 4 & 2 of 4
 (Pacific version shown on sheets 3 of 4 & 4 of 4)

SET UP GAUGE	LOC	DIST	REVISIONS			
2119599-2	A	66	REV	DATE	BY	APPV
			1	DEVELOPMENT	12AUG2013	CC UG
			A	RELEASED	18SEP2013	BH GB

REV	DATE	BY	APPV	DESCRIPTION	ITEM NO		
-	-	1	-	-	2119957-2	APPLICATOR SHIM PACK	260
-	-	1	-	1	8-21084-0	O-RING, .676 ID, .070 DIA. MAT.	252
-	-	-	-	1	2119640-1	PUSH ROD, AIR FEED	250
-	-	-	-	1	2079988-1	BUSHING, LCH5-12, MISUMI	249
-	-	-	-	1	2119641-1	FEED CAM, AIR FEED	248
-	-	1	-	1	2119798-1	DETENT PIN	247
-	-	1	-	1	1-22279-3	SPRING, COMPRESSION	246
-	-	1	-	-	2119759-1	RAM, AMP STYLE, END FEED, NON-ADJUST	245
-	-	1	1	1	2119082-9	CAM, SNAIL, INSULATION ADJUSTMENT	244
-	-	1	1	1	2079764-1	WASHER, WAVE SPRING, CREST-TO-CREST	243
-	-	1	1	1	2119083-1	RETAINER, INSULATION DIAL	242
-	-	2	2	-	2168400-7	SHCS, LOW HEAD, RoHS, M5 X 10	240
-	-	-	-	1	2119580-1	MECHANICAL FEED ASSEMBLY	239
-	-	-	-	1	2063440-1	AIR FEED MODULE	238
-	-	1	1	-	2119740-2	TAG, IDENTIFICATION	213
-	-	1	1	1	1-455888-0	SPACER, CRIMPER	185
-	-	REFREF	-	-	1901697-1	FEED FINGER ASSEMBLY, EF	183
-	-	-	-	2	21045-3	RING, RETAIN, EXTERN, 3/16 CRESCENT	172
-	-	1	1	1	994969-1	MAGNET, RARE EARTH HIGH ENERGY	166
-	-	REFREF	REFREF	REFREF	994970-2	COUNTER, MAGNETIC	164
-	-	-	-	1	240638-1	SPRING, FEED FINGER	163
-	-	-	-	1	3-23627-7	PIN, RETAIN, GRVD, 3/16 X .854	137
-	-	REFREF	-	-	SEE NOTE 4	MEMORY CHIP, PROGRAMMED	135
-	-	1	1	-	1633743-1	SERVO FEED LATCH ASM	133
-	-	1	1	1	455888-4	SPACER, CRIMPER	82
-	-	1	1	1	2119956-2	DOCUMENTATION PACKAGE	71
-	-	2	2	2	2-18032-2	SCR, SET, FLT POINT M3 X 10.0	70
-	-	1	-	1	2119740-1	TAG, IDENTIFICATION	67
-	-	2	2	2	2168078-1	SCREW, DRIVE, RH, RoHS, 2 x .188	66
-	-	1	-	1	992763-5	LIMITER, ADJUSTMENT BOLT	63
-	-	3	-	3	2079383-4	SCR, BHSC, RoHS (M4 X 8)	60
-	-	1	1	1	5-18022-5	SCR, HEX HD CAP, M4 X 6.0	59
-	-	-	-	1	2063961-1	FEED FINGER	58
-	-	4	4	4	2168400-4	SHCS, LOW HEAD, RoHS, M4 X 8	57
-	-	2	2	2	2168083-3	SCR, SKT HD CAP, RoHS, M4 X 12.0	56
-	-	2	2	2	5018030-2	NUT, HEX, REG, RoHS, M4	55
-	-	2	2	2	5018030-1	NUT, HEX, REG, RoHS, M3	54
-	-	2	2	2	986965-8	NUT, LOCK, HEX, TORQUE (M4)	53
-	-	-	-	1	2119792-1	PAWL, EF, AIR	51
-	-	-	-	1	18023-9	SCR, SKT HD CAP M4 X 6.0	49
-	-	-	-	1	2119652-1	FEED CAM, PRE FEED	48
-	-	-	-	1	2119653-1	FEED CAM, POST FEED	47
-	-	1	1	1	2119655-5	APPLICATOR BASIC ASSEMBLY, EF	46
-	-	1	-	1	2119369-1	RAM, AMP STYLE, END FEED	44
-	-	1	1	1	2079383-7	SCR, BHSC, RoHS (M8 X 25)	41
-	-	1	-	1	2119645-1	DISC, NUMBERED FA WIRE ADJUSTMENT	40
-	-	1	-	1	2119957-1	APPLICATOR SHIM PACK	39
-	-	1	1	1	1-2119644-2	RAM WASHER, PRECISION	38
-	-	1	1	1	2119085-1	FA HEAD, ATLANTIC STYLE	37
-	-	1	-	1	2119092-1	BOLT, ADJUSTMENT	35
-	-	8	8	8	1-18028-2	WASHER, FLAT, REG M4	33
-	-	2	2	2	2168083-9	SCR, SKT HD CAP, RoHS, M4 X 20	31
-	-	2	2	2	1-2168083-0	SCR, SKT HD CAP, RoHS, M4 X 10	29
-	-	1	1	1	240639-1	STRIPPER (MACHINING)	27
-	-	2	2	2	1320906-1	STUD, THREADED	25
-	-	1	1	1	1752371-5	PLATE, STRIP GUIDE	24
-	-	2	2	2	2-22281-3	SPRING, COMPRESSION	22
-	-	1	1	1	1752373-4	DRAG	20
-	-	1	1	1	1901696-2	STRIP GUIDE, REAR	19
-	-	1	1	1	1901695-2	STRIP GUIDE, FRONT	18
-	-	4	4	4	1-2079383-1	SCR, BHSC, RoHS (M6 X 12)	17
-	-	1	1	1	240644-1	PLATE, REAR SHEAR	11
-	-	2	2	2	1-240645-1	SPACER, SHEAR PLATE	10
-	-	1	1	1	240642-1	PLATE, FRONT SHEAR	9
-	-	1	1	1	2-1803001-6	ANVIL, COMBINATION, END FEED	8
-	-	1	1	1	8-240651-7	BLADE, SLUG	7
-	-	-	-	-	-	-	6
-	-	1	1	1	1-240641-8	SPACER	5
-	-	1	1	1	238009-4	BLOCK, FL CRIMPER SPACER	4
-	-	1	1	1	1803018-8	CRIMPER, INSULATION O	3
-	-	1	1	1	455888-2	SPACER, CRIMPER	2
-	-	1	1	1	2-1633860-4	CRIMPER, WIRE	1

DIMENSIONS:		TOLERANCES UNLESS OTHERWISE SPECIFIED:		MATERIAL:		FINISH:		WEIGHT:		SCALE:	
mm	0 PLC ±.5	1 PLC ±.3	2 PLC ±.13	3 PLC ±.013	4 PLC ±.0001	ANGLES	±.0001				
MATERIAL:		FINISH:		WEIGHT:		SCALE:		SHEET:		REV:	
						A 00779		C=2150358		A	

LOC		DIST		REVISIONS			
A	66	P	LTM	DESCRIPTION	DATE	OWN	APVD
		-		SEE SHEET 1			

FEED TYPE MECHANICAL

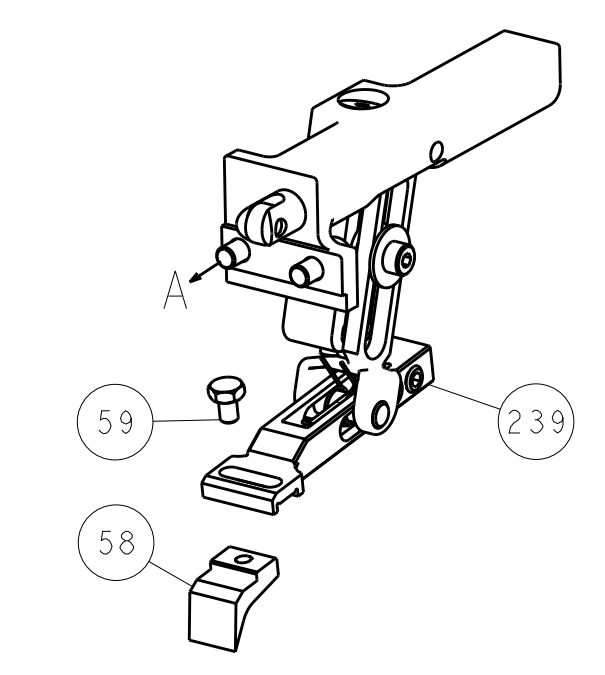

PNEUMATIC

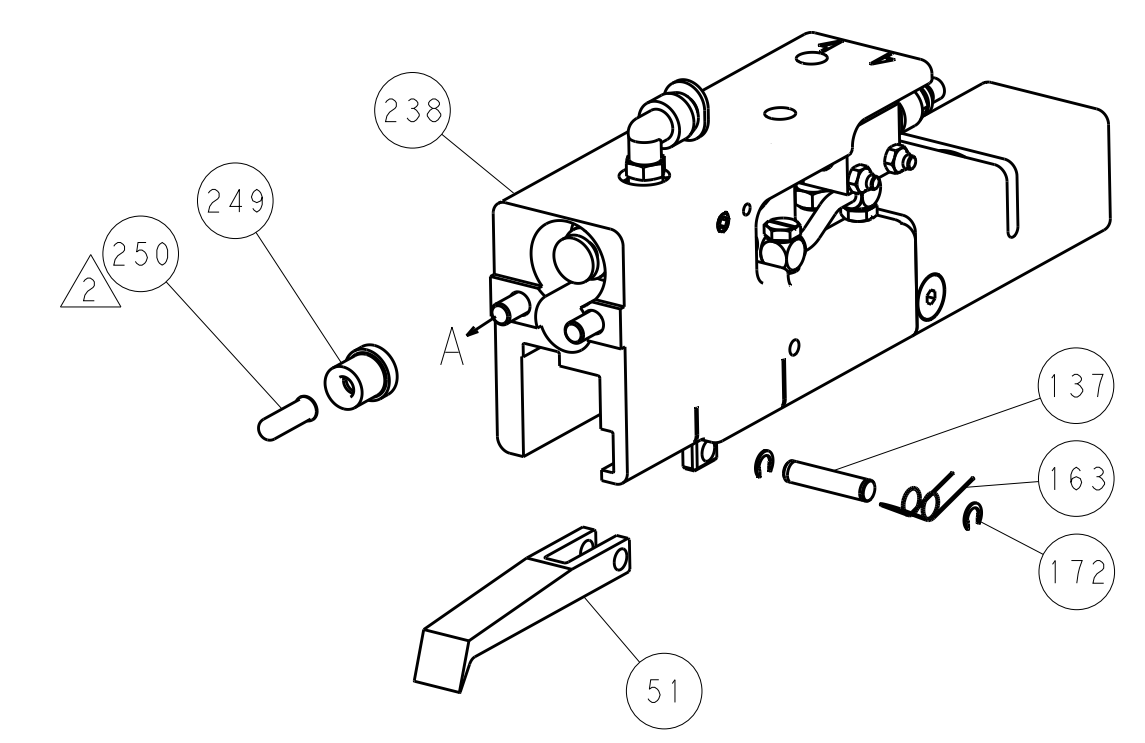

SERVO LATCH PLATE

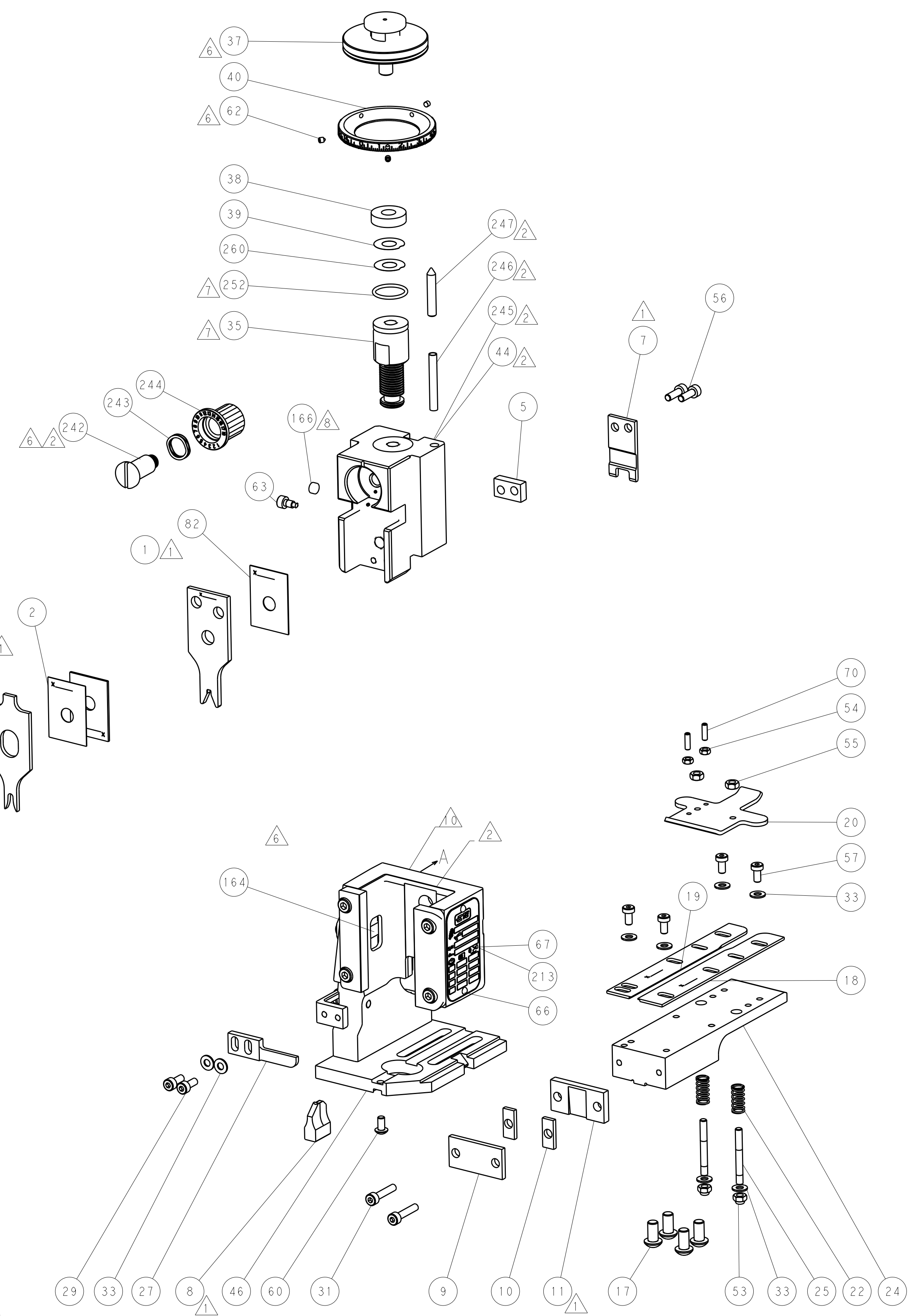
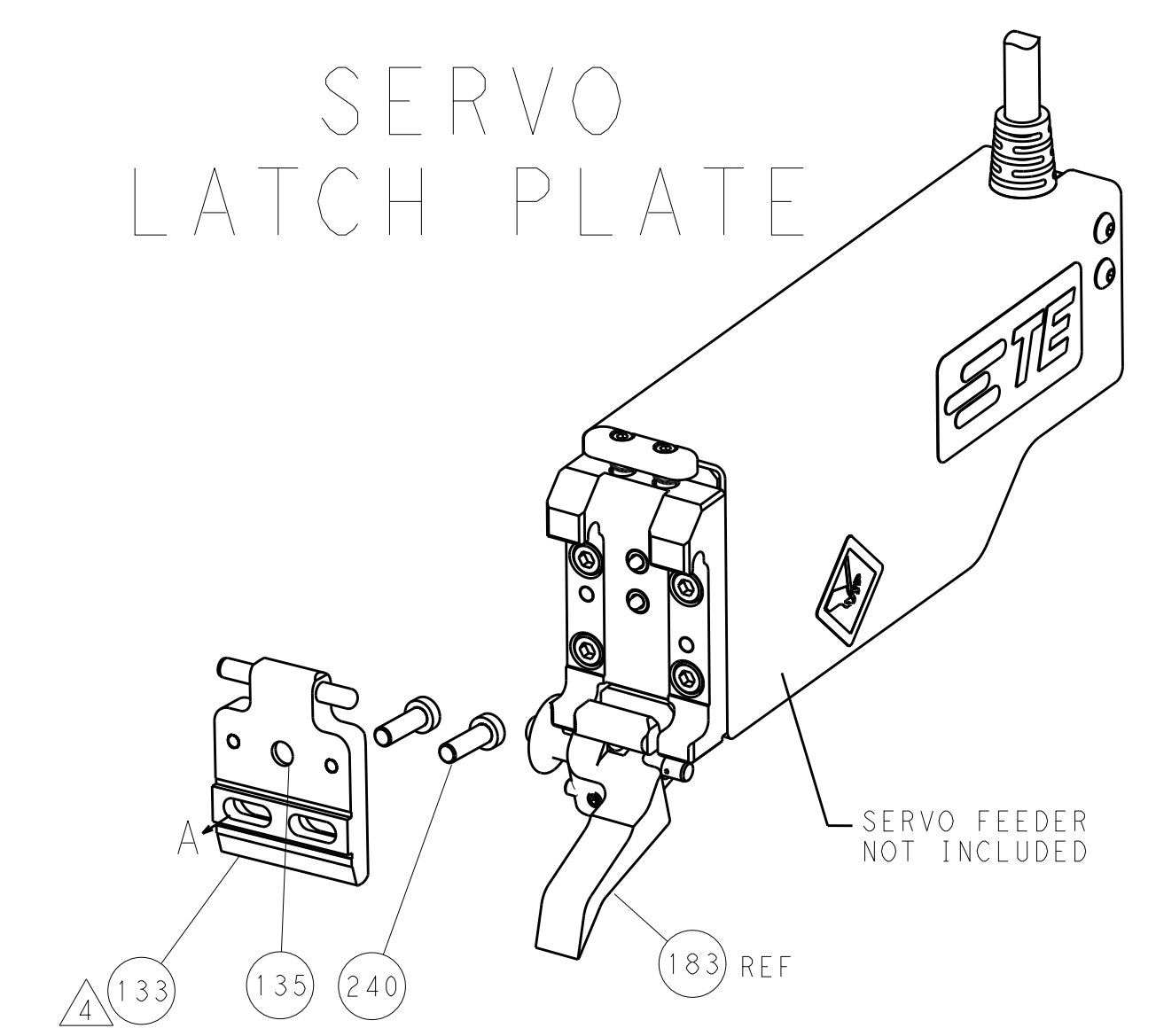

CAM POSITIONS

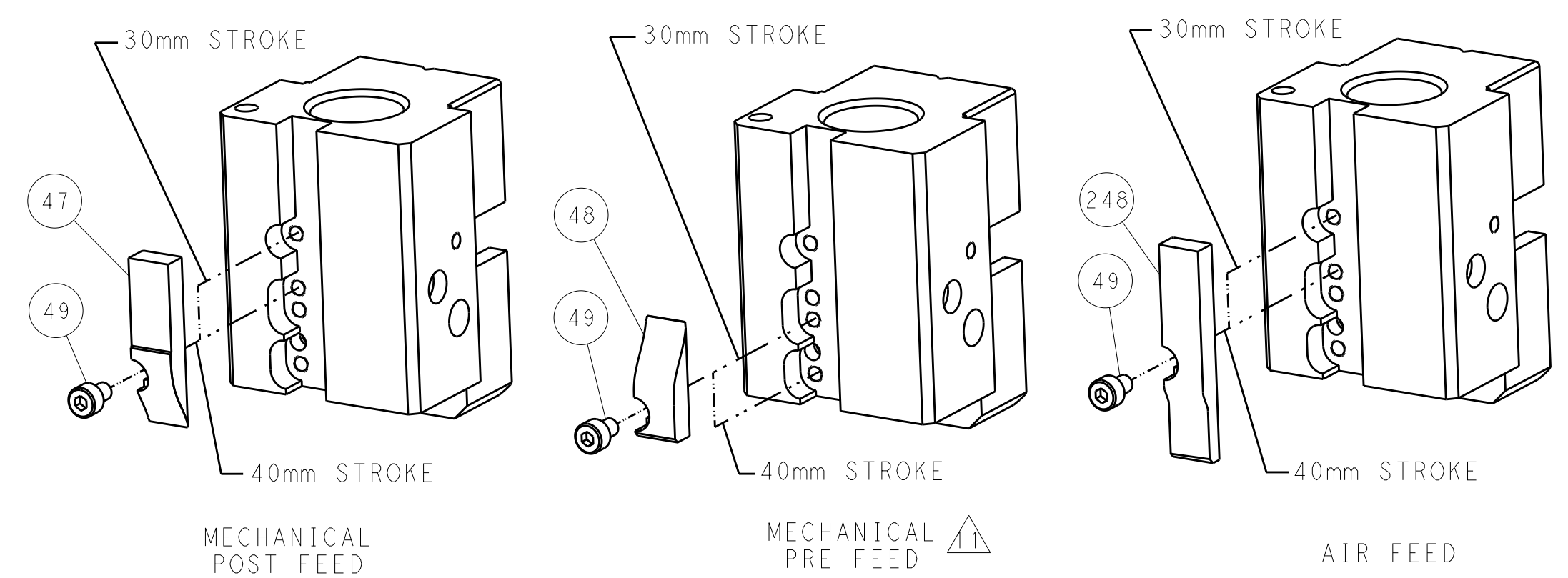

ATLANTIC VERSION
 Shown on sheets 1 of 4 & 2 of 4
 (Pacific version shown on sheets 3 of 4 & 4 of 4)

DIMENSIONS:		TOLERANCES UNLESS OTHERWISE SPECIFIED:		DWN L.C. CHEN 12AUG2013		TE Connectivity	
mm		0 PLC ±0.5		CHK U. GUO 12AUG2013		Harrisburg, PA 17105-3608	
Ø		1 PLC ±0.13		APVD J. CRUZ 12AUG2013		NAME	
H		2 PLC ±0.013		PRODUCT SPEC		Ocean End Feed	
ANGLES		3 PLC ±0.001		APPLICATION SPEC		Applicator	
FINISH		4 PLC ±0.0001		WEIGHT		SIZE CAGE CODE DRAWING NO	
MATERIAL		5 PLC ±0.0001		Customer Accessible Production Drawing		A1 00779 ©=2150358	
				SCALE 1:1		RESTRICTED TO	
				SHEET 2 OF 4		REV A	

PACIFIC VERSION TERMINATOR INTERFACE ADAPTER	PART NUMBER	REVISION	DESCRIPTION	FEED TYPE	APPLICATOR STYLE CONVERSION CHART						
					CONVERT TO	PART NUMBERS REQUIRED					
	2-2150358-1	A	FINE CRIMP HEIGHT ADJUST	MECHANICAL	PNEUMATIC FEED	2119950-1	2119792-1	-	2119641-2	-	2063440-1
					SERVO LATCH PLATE	2119951-1	1901697-1	8-2150358-5	-	-	2168400-7 (QUANTITY 2)
					SMART APPLICATOR	2161326-1	-	8-2150358-4	-	-	-
	2-2150358-2	A	FINE CRIMP HEIGHT ADJUST	PNEUMATIC	MECHANICAL FEED	2119949-1	2063961-1	5-18022-5	2119653-2	-	-
					SERVO LATCH PLATE	2119951-1	1901697-1	8-2150358-5	-	-	2168400-7 (QUANTITY 2)
					SMART APPLICATOR	2161326-1	-	8-2150358-4	-	-	-
	2-2150358-5	A	FINE CRIMP HEIGHT ADJUST	SERVO LATCH PLATE	MECHANICAL FEED	2119949-1	2063961-1	5-18022-5	2119653-2	-	-
					PNEUMATIC FEED	2119950-1	2119792-1	-	2119641-2	-	2063440-1
	2-2150358-7	A	FINE CRIMP HEIGHT ADJUST	NONE	-	-	-	-	-	-	-
	7-2150358-7	A	CRIMP TOOLING KIT	-	-	-	-	-	-	-	-

APPLICATOR DATA		
CRIMP	SIZE	TYPE
WIRE	2.54 mm (.100)	F
INSUL	3.56 mm (.140)	O
APPL INSTRUCTIONS 408-10390		

TERMINAL DATA: JUNO TERMINAL		TE CRIMP SPECIFICATION	
TERMINAL NAME: RING			
WIRE STRIP LENGTH		INSULATION DIAMETER RANGE	
3.60-3.90 mm (.142-.154 IN)		Ø0.00-2.70 mm (.000-.106 IN)	
TERMINAL APPLICATION SPECIFICATION	NONE		
TERMINALS APPLIED			
TE TERMINAL	JUNO TERMINAL	TE TERMINAL	JUNO TERMINAL
2113363-1	E86000-06	2113363-2	S0107-00

WIRE SIZE	CRIMP HEIGHT mm [INCH]	CRIMP HEIGHT REFERENCE SETTING
18 AWG	1.52+/-0.05 [.060+/- .002]	8.1
20 AWG	1.40+/-0.05 [.055+/- .002]	9.3

- RECOMMENDED SPARE PARTS
- GREASE BEARING SURFACES LIGHTLY
- 3. LUBRICATE DAILY PER THE APPLICATOR INSTRUCTION SHEET SUPPLIED WITH THE APPLICATOR.
- APPLICATOR SPECIFIC DATA TO BE ENTERED INTO BLANK MEMORY CHIP AT ASSEMBLY. SEE BELOW FOR PART NUMBER:
 MECHANICAL FEED WITH "SMART APPLICATOR" CONVERSION: 8-2150358-4
 PNEUMATIC FEED WITH "SMART APPLICATOR" CONVERSION: 8-2150358-4
 SERVO FEED WITH "FINE CRIMP HEIGHT ADJUST": 8-2150358-5
- 5. ADJUSTMENT OF THE STRIPPER MAY BE REQUIRED WHEN MOVING THE APPLICATOR BETWEEN BENCH AND LEADMAKER APPLICATIONS.
- APPLY PART NUMBER 1-23419-5 LOCTITE TO THREADS OF ITEMS 62 & 242.
- GREASE THREADS, GROOVE AND O-RING ON ITEMS 139 & 153.
- MAGNET, ITEM 166 MUST BE ORIENTED CORRECTLY IN ORDER TO PROPERLY ACTUATE THE COUNTER.
- CRIMP HEIGHT REFERENCE SETTING WAS THE SETTING USED WHEN THE APPLICATOR WAS QUALIFIED AT THE FACTORY. ADJUSTMENT MAY BE NECESSARY WHEN RUNNING APPLICATOR IN THE FIELD.
- SPARE FEED CAM STORAGE LOCATION REFER TO INSTRUCTION SHEET FOR ADDITIONAL INFORMATION.
- THE RECOMMENDED SET-UP FOR END FEED APPLICATORS IS POST-FEED WITH ITEM 2119653-1. THE APPLICATOR CAN BE CONFIGURED FOR PRE-FEED WITH ITEM 2119652-1 BUT MAY ENCOUNTER PROBLEMS WITH SOME APPLICATIONS. FEED ISSUES OR TERMINAL JAMMING MAY OCCUR IN THE PRE-FEED CONFIGURATION.

***WARNING**
 ON INSTALLATION, SET WIRE DISC, ITEM 40 TO LARGEST WIRE SIZE SETTING. USE OF SETTINGS BELOW MINIMUM REQUIRED CRIMP HEIGHT SETTING WILL CAUSE DAMAGE TO CRIMP TOOLING.

PACIFIC VERSION
 Shown on sheets 3 of 4 & 4 of 4
 (Atlantic version shown on sheets 1 of 4 & 2 of 4)

SET UP GAUGE	LOC	DIST	REVISIONS			
2119599-2	A	66	REV	DATE	BY	APPV
			-	SEE SHEET 1		

-	1	1	1	1	2119782-1	FINE ADJUST HEAD ASM, PACIFIC STYLE	251
-	-	-	1	-	2119640-1	PUSH ROD, AIR FEED	250
-	-	-	1	-	2079988-1	BUSHING, LCH5-12, MISUMI	249
-	1	1	1	1	1-22279-3	SPRING, COMPRESSION	246
-	1	1	1	1	2119082-9	CAM, SNAIL, INSULATION ADJUSTMENT	244
-	1	1	1	1	2079764-1	WASHER, WAVE SPRING, CREST-TO-CREST	243
-	1	1	1	1	2119083-1	RETAINER, INSULATION DIAL	242
-	-	2	-	-	2168400-7	SHCS, LOW HEAD, RoHS, M5 X 10	240
-	-	-	-	1	2119580-1	MECHANICAL FEED ASSEMBLY	239
-	-	-	1	-	2063440-1	AIR FEED MODULE	238
-	-	1	-	-	2119740-2	TAG, IDENTIFICATION	213
-	4	4	4	4	2079383-9	SCR, BHSC, RoHS (M6 X 20)	186
-	1	1	1	1	1-455888-0	SPACER, CRIMPER	185
-	-	REF	-	-	1901697-1	FEED FINGER ASSEMBLY, EF	183
-	-	-	2	-	21045-3	RING, RETAIN, EXTERN, 3/16 CRESCENT	172
-	1	1	1	1	994969-1	MAGNET, RARE EARTH HIGH ENERGY	166
-	REF	REF	REF	REF	994970-2	COUNTER, MAGNETIC	164
-	-	-	1	-	240638-1	SPRING, FEED FINGER	163
-	1	1	1	1	8-21084-1	O-RING, .801 ID, .070 DIA. MAT.	153
-	-	-	1	-	2119641-2	FEED CAM, AIR FEED	152
-	1	1	1	1	2119798-2	DETENT PIN	145
-	1	1	1	1	2079383-8	SCR, BHSC, RoHS (M4 X 16)	144
-	-	-	-	1	2119653-2	FEED CAM, POST FEED	142
-	1	1	1	1	2119655-6	APPLICATOR BASIC ASSEMBLY, EF	141
-	1	1	1	1	2119651-1	RAM, ASIAN STYLE, END FEED	140
-	1	1	1	1	2119092-2	BOLT, ADJUSTMENT	139
-	-	-	1	-	3-23627-7	PIN, RETAIN, GRVD, 3/16 X .854	137
-	-	REF	-	-	SEE NOTE 4	MEMORY CHIP, PROGRAMMED	135
-	-	1	-	-	1633743-1	SERVO FEED LATCH ASM	133
-	1	1	1	1	455888-4	SPACER, CRIMPER	82
-	1	1	1	1	2119956-2	DOCUMENTATION PACKAGE	71
-	2	2	2	2	2-18032-2	SCR, SET, FLT POINT M3 X 10.0	70
-	1	-	1	1	2119740-1	TAG, IDENTIFICATION	67
-	2	2	2	2	2168078-1	SCREW, DRIVE, RH, RoHS, 2 x .188	66
-	1	1	1	1	2119793-1	LIMITER, ADJUSTMENT BOLT	63
-	3	3	3	3	992763-5	SCR, SET, SOC, CONE POINT, M3 X 4.0	62
-	-	-	-	1	5-18022-5	SCR, HEX HD CAP, M4 X 6.0	59
-	-	-	-	1	2063961-1	FEED FINGER	58
-	4	4	4	4	2168400-4	SHCS, LOW HEAD, RoHS, M4 X 8	57
-	2	2	2	2	2168083-3	SCR, SKT HD CAP, RoHS, M4 X 12.0	56
-	2	2	2	2	5018030-2	NUT, HEX, REG, RoHS, M4	55
-	2	2	2	2	5018030-1	NUT, HEX, REG, RoHS, M3	54
-	2	2	2	2	986965-8	NUT, LOCK, HEX, TORQUE (M4)	53
-	-	-	1	-	2119792-1	PAWL, EF, AIR	51
-	-	-	1	2	18023-9	SCR, SKT HD CAP M4 X 6.0	49
-	-	-	-	1	2119652-1	FEED CAM, PRE FEED	48
-	1	1	1	1	2079383-7	SCR, BHSC, RoHS (M8 X 25)	41
-	1	1	1	1	2119645-1	DISC, NUMBERED FA WIRE ADJUSTMENT	40
-	1	1	1	1	2119957-1	APPLICATOR SHIM PACK	39
-	1	1	1	1	1-2119644-2	RAM WASHER, PRECISION	38
-	8	8	8	8	1-18028-2	WASHER, FLAT, REG M4	33
-	2	2	2	2	2168083-9	SCR, SKT HD CAP, RoHS, M4 X 20	31
-	2	2	2	2	1-2168083-0	SCR, SKT HD CAP, RoHS, M4 X 10	29
-	1	1	1	1	240639-1	STRIPPER (MACHINING)	27
-	2	2	2	2	1320906-1	STUD, THREADED	25
-	1	1	1	1	1752371-5	PLATE, STRIP GUIDE	24
-	2	2	2	2	2-22281-3	SPRING, COMPRESSION	22
-	1	1	1	1	1752373-4	DRAG	20
-	1	1	1	1	1901696-2	STRIP GUIDE, REAR	19
-	1	1	1	1	1901695-2	STRIP GUIDE, FRONT	18
-	1	1	1	1	240644-1	PLATE, REAR SHEAR	11
-	2	2	2	2	1-240645-1	SPACER, SHEAR PLATE	10
-	1	1	1	1	240642-1	PLATE, FRONT SHEAR	9
-	1	1	1	1	2-1803001-6	ANVIL, COMBINATION, END FEED	8
-	1	1	1	1	8-240651-7	BLADE, SLUG	7
-	-	-	-	-	-	-	6
-	1	1	1	1	1-240641-8	SPACER	5
-	1	1	1	1	238009-4	BLOCK, FL CRIMPER SPACER	4
-	1	1	1	1	1803018-8	CRIMPER, INSULATION O	3
-	1	1	1	1	455888-2	SPACER, CRIMPER	2
-	1	1	1	1	2-1633860-4	CRIMPER, WIRE	1

DIMENSIONS:		TOLERANCES UNLESS OTHERWISE SPECIFIED:		DRAWN		CHK		APVD		NAME	
mm	0 PLC ±.5	1 PLC ±.5	2 PLC ±.5	3 PLC ±.5	4 PLC ±.5	5 PLC ±.5	6 PLC ±.5	7 PLC ±.5	8 PLC ±.5	9 PLC ±.5	10 PLC ±.5
	ANGLES ±.0001										
MATERIAL	FINISH	WEIGHT	SCALE	SIZE	CAGE CODE	DRAWING NO	RESTRICTED TO	Customer Accessible Production Drawing			
			1:1	A1	00779	©=2150358		SHEET 3 OF 4 REV A			

LOC		DIST		REVISIONS			
A	66	P	LTM	DESCRIPTION	DATE	DWN	APVD
		-	-	SEE SHEET 1	-	-	-

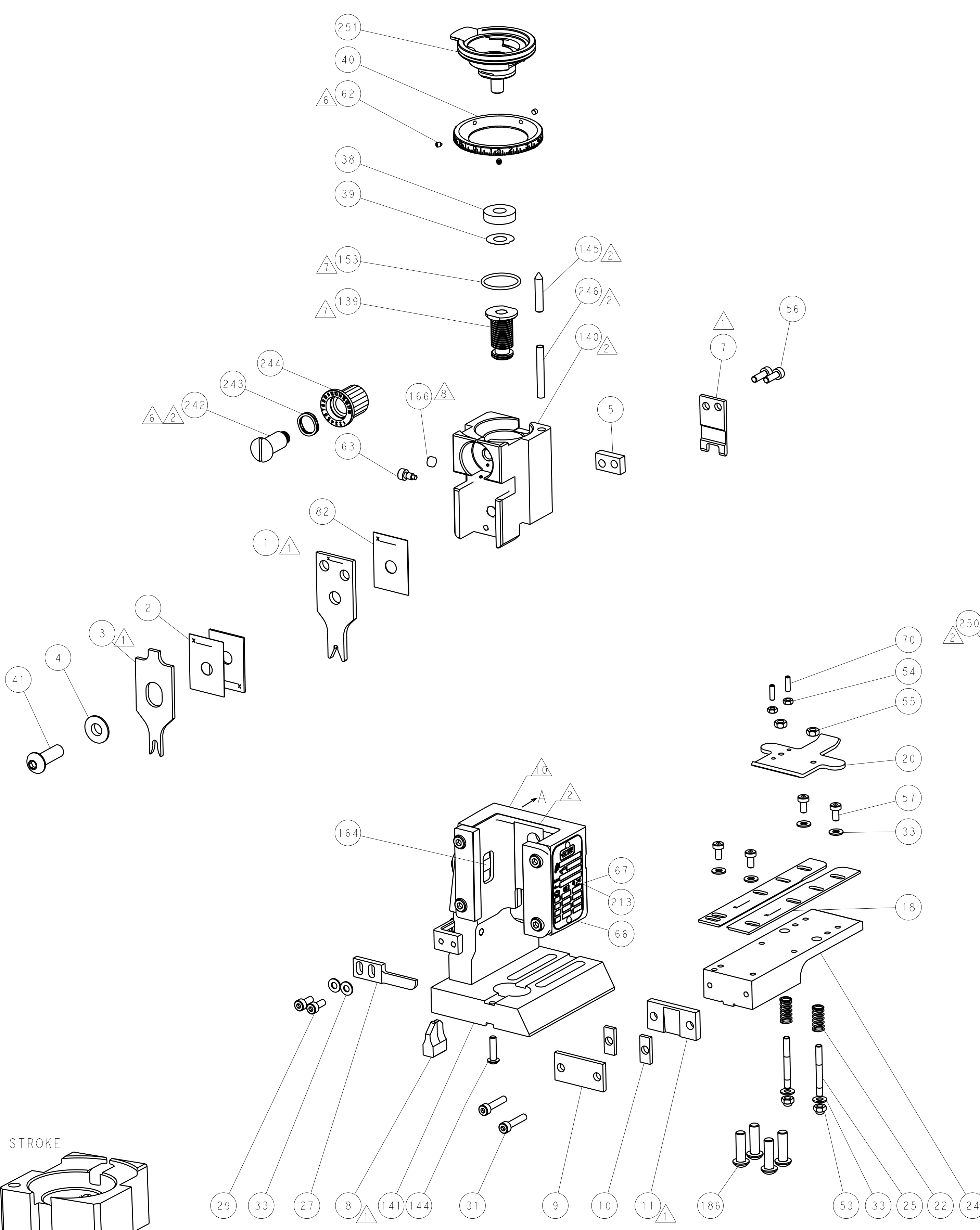

FEED TYPE
MECHANICAL

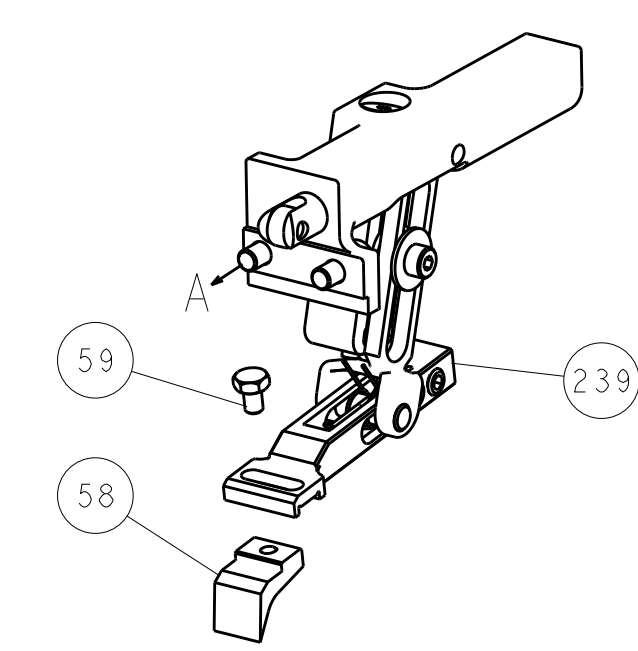

PNEUMATIC

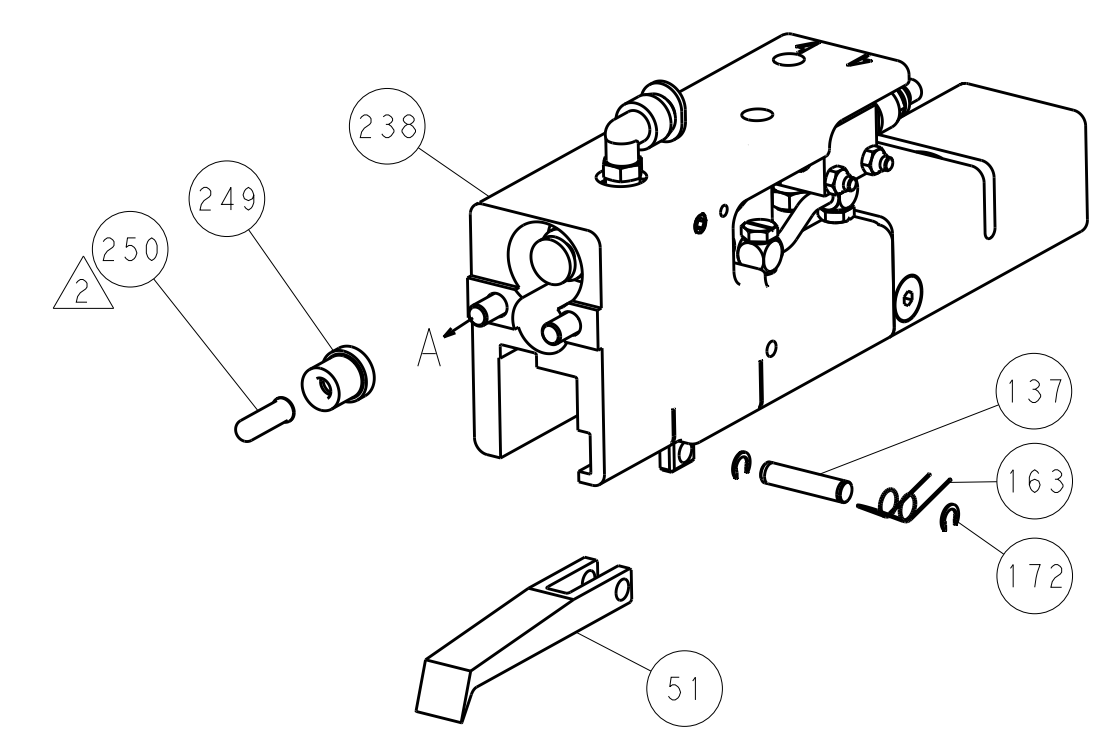

SERVO
LATCH PLATE

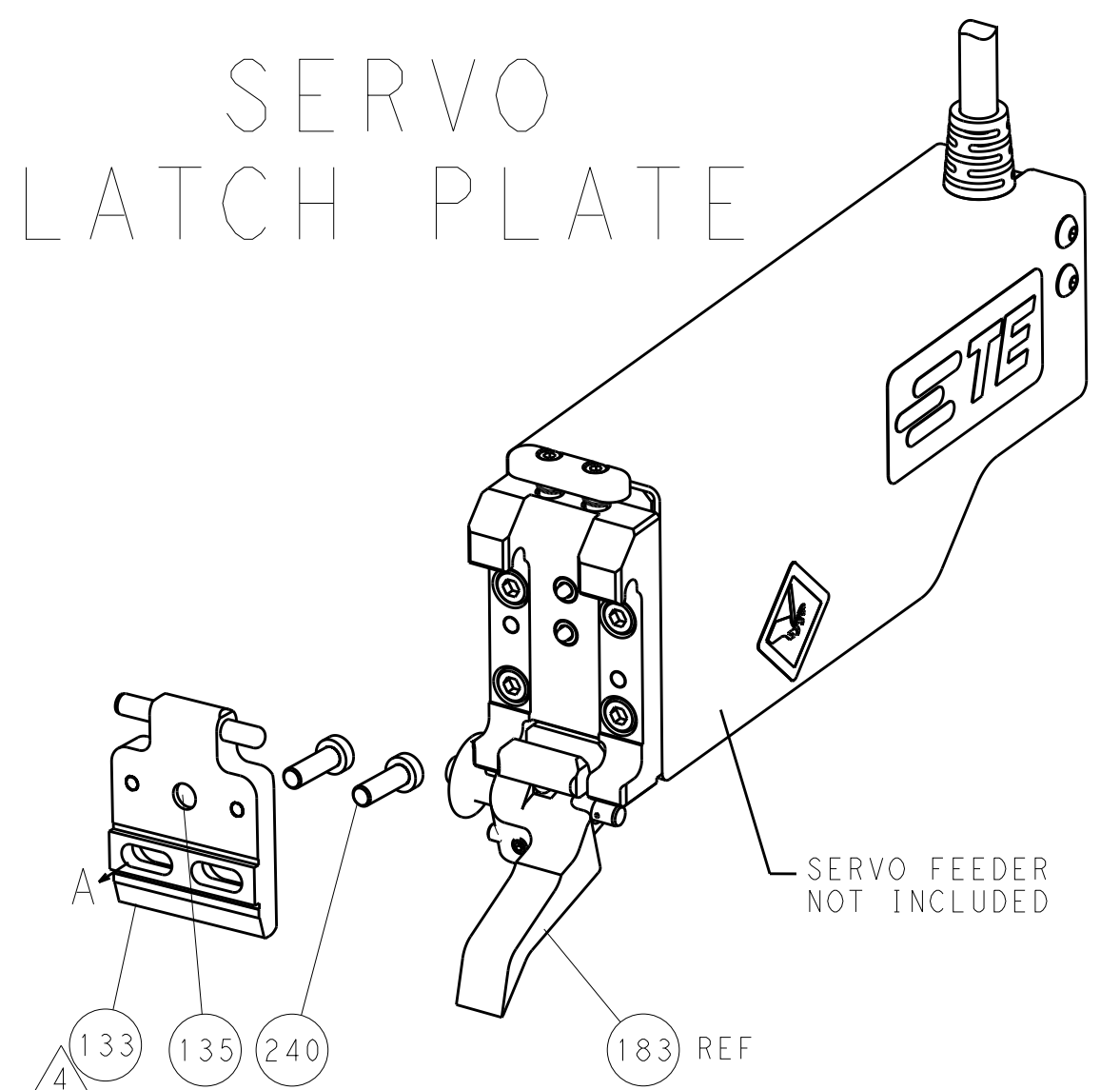

CAM POSITIONS

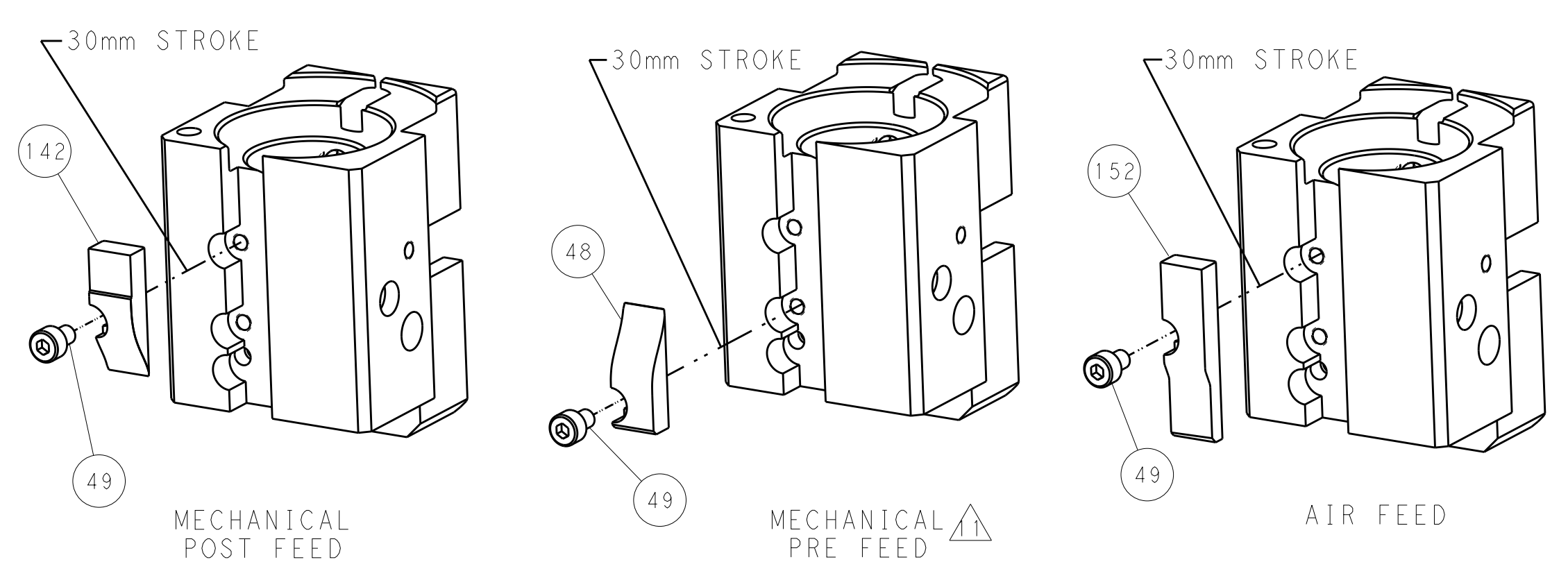

PACIFIC VERSION
 Shown on sheets 3 of 4 & 4 of 4
 (Atlantic version shown on sheets 1 of 4 & 2 of 4)

DIMENSIONS:		TOLERANCES UNLESS OTHERWISE SPECIFIED:		DWN L.C. CHEN 12AUG2013		TE Connectivity Harrisburg, PA 17105-3608	
mm	0 PLC ±0.5	1 PLC ±0.5	2 PLC ±0.13	3 PLC ±0.13	CHK U. GUO 12AUG2013	NAME Ocean End Feed Applicator	
	4 PLC ±0.013	5 PLC ±0.001	ANGLES ±0.001	APVD J. CRUZ 12AUG2013	PRODUCT SPEC		RESTRICTED TO
MATERIAL	FINISH	WEIGHT		SCALE		SHEET 4 OF 4 REV A	
		Customer Accessible Production Drawing		SCALE 1:1		REV A	