

- 1 MOLDDED PARTS: FLAME RETARDANT 94V-0 RATED THERMOPLASTIC, BLACK.
SHELL: CARBON STEEL
CONTACTS: PHOSPHOR BRONZE
EYELETS: BRASS
SCREWLOCKS: ZINC
INSERTS: ZINC
- 2 SHELL: .000100 MIN TIN OVER .000050 MIN COPPER.
CONTACTS: .000030 MIN GOLD FOR A DISTANCE OF .100 MIN FROM MATING END, .000100 MIN TIN ON OPPOSITE END, ALL OVER .000050 MIN NICKEL.
EYELETS: .000100 MIN TIN OVER COPPER FLASH.
SCREWLOCKS: CLEAR CHROMATE
INSERTS: CLEAR CHROMATE
- 3 OBSOLETE PARTS: OBSOLETE CIS STREAMLINING PER D.RENAUD/D.SINISI

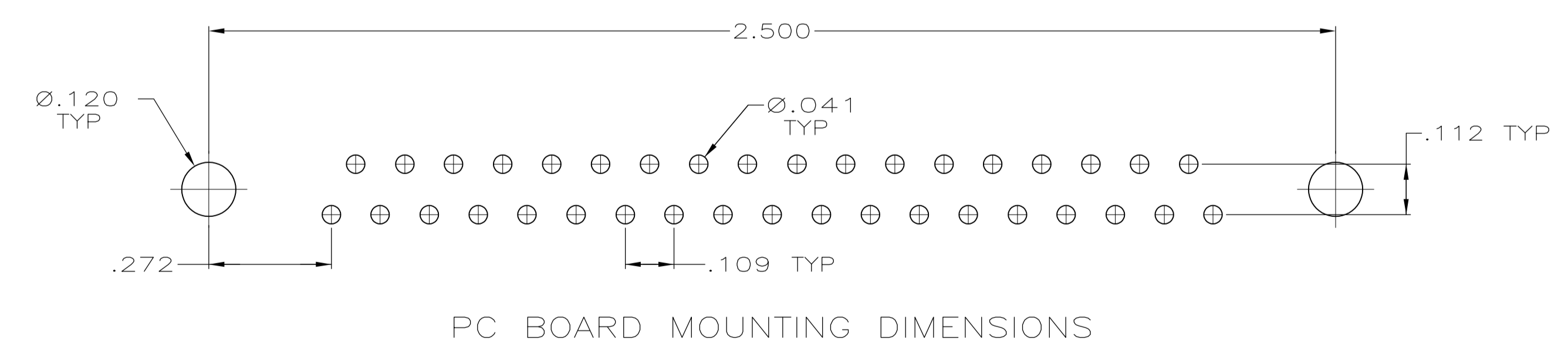
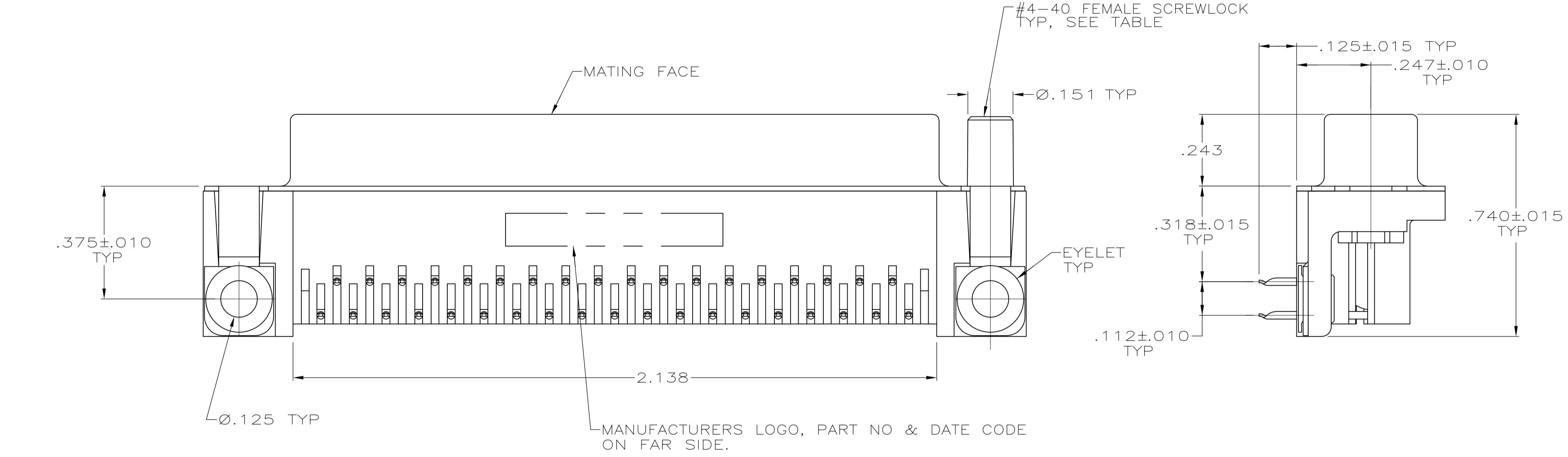

3 OBSOLETE

FEMALE SCREWLOCKS	5745784-6
THREADED INSERTS	5745784-4
NONE	5745784-2
MOUNTING HARDWARE	PART NUMBER

**COPYRIGHT 2005
TE CONNECTIVITY CORP
ALL RIGHTS RESERVED**

THIS DRAWING IS A CONTROLLED DOCUMENT.		DIN A FERNANDEZ-DOCKS 04-07-05		TE Connectivity	
DIMENSIONS: INCHES		CHK S BOLASH 04-07-05		RCPT ASSY, SIZE 4, 37 POSN, RTANG, AMPLIMITE HD-20, WITH METAL SHELL, WITH OR WITHOUT SCREWLOCKS OR INSERTS	
TOLERANCES UNLESS OTHERWISE SPECIFIED:		APVD M WALMSLEY 04-07-05		NAME	
0. PLC	± .005	PRODUCT SPEC		108-40025	
1. PLC	± .005	APPLICATION SPEC		114-40010	
2. PLC	± .005	SIZE		A1	
3. PLC	± .005	CAGE CODE		00779	
4. PLC	± .005	DRAWING NO		5745784	
ANGLES	± .2°	WEIGHT		-	
MATERIAL	1	CUSTOMER DRAWING		SCALE 4:1 SHEET 1 of 1 REV P	
FINISH	2				