

REV.	DATE	DESCRIPTION
A	12/29/00	REVISE PLATING TO SILVER -BODY, CONTACT PIN, COUPLING NUT
B	11/01/07	REVISE PLATING, UPDATE DRAWING FORMAT

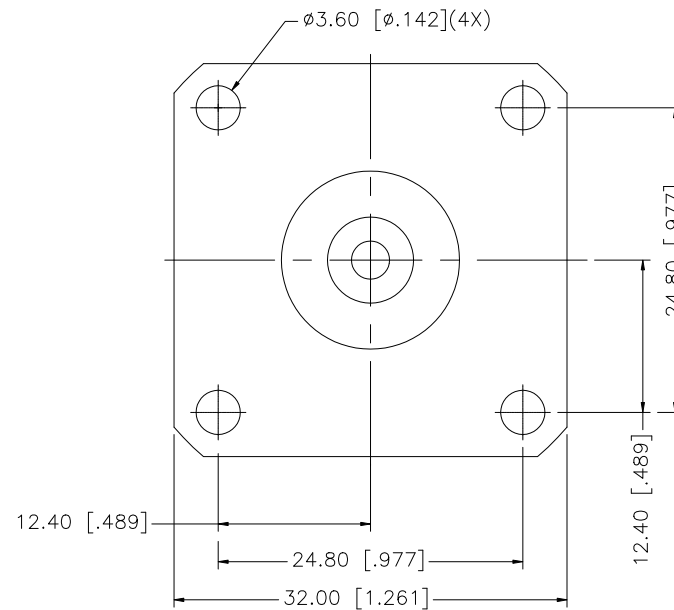
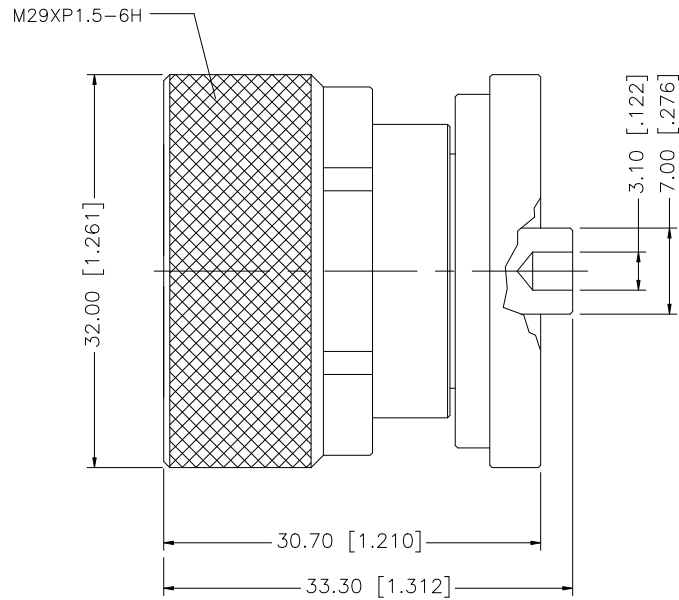

DESCRIPTION	MATERIAL	FINISH	QTY
8			
7			
6	COVER	P.E.	BLUE 1
5	CONTACT PIN	BRASS	SILVER 1
4	SHELL	BRASS	NEXCOTE 1
3	CONTACT PIN	BRASS	SILVER 1
2	INSULATOR	TEFLON	NATURAL 1
1	BODY	BRASS	NEXCOTE 1

UNLESS OTHERWISE SPECIFIED DIMENSIONS ARE IN MILLIMETERS. DIMENSIONS IN [] ARE IN INCHES AND FOR CUSTOMER REFERENCE ONLY.

UNLESS OTHERWISE SPECIFIED TOLERANCES FOR MILLIMETERS ARE:
0.5 - 8mm ± 0.20mm
8 - 30mm ± 0.40mm
30 - 120mm ± 0.50mm

UNLESS OTHERWISE SPECIFIED TOLERANCES FOR INCHES ARE:
.020 - .315 = ± 0.007"
.315 - 1.180 = ± 0.015"
1.180 - 4.724 = ± 0.020"

DO NOT SCALE DRAWING

APPROVALS	DATE
DRAWN G.R.S.	11/01/07
CHECKED	
ISSUED	
SHEET 1 OF 1	
CAD FILE	C:/272/272132.DWG

Amphenol Connex			
PART DESCRIPTION			
7/16 PANEL RECEPTACLE PLUG CENTER CONTACT WITH SOLDER BUCKET			
PART NO.		272132	
DWG. NO.	272132.DWG	REV.	B
SIZE	A	SCALE	NA