

REVISIONS						
ZONE	REV.	ECN	DESCRIPTION	BY	DATE	APPROVED
ALL SHT1, SHT5	E	180004	CHANGED DRAWING NUMBER ADDED U36-A1070-X000T AND FOOTPRINT FOR SOLDER RING OPTION	KAW	01/10/2018	AYZ
SHT 1 3-A5, D2, D6 4-A5, D2, D6 5-A5, D6 5-D3	F	180049	REMOVED U36-A1040-X000T OPTION ADDED DIMENSIONS ADDED DIMENSIONS ADDED DIMENSIONS REVISED SOLDER RING PAD DIMENSIONS	KAW	07/17/2018	AYZ

**AMPHENOL PART NUMBER CONFIGURATION**

UE36-A10X0-X000T

**TERMINATION OPTION**  
1 = STANDARD SINGLE SIDE  
7 = SOLDER RINGS

**PACKAGING**  
T = TAPE AND REEL

**PLATING OPTION**  
2 = 0.76µm GOLD OVER PALLADIUM-NICKEL  
AT MATING AREA  
2.54µm-6.35µm MATTE TIN TERMINATION  
3 = 0.76µm GOLD AT MATING AREA  
2.54µm-6.35µm MATTE TIN TERMINATION  
6 = 0.38µm GOLD AT MATING AREA  
2.54µm-6.35µm MATTE TIN TERMINATION

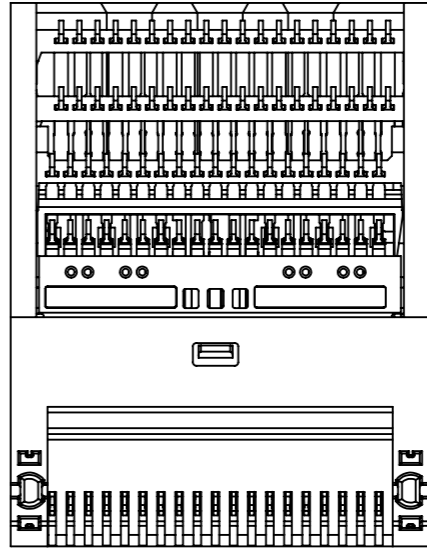

UE36-A1010-X000T  
(STANDARD SINGLE-SIDE MOUNTING)

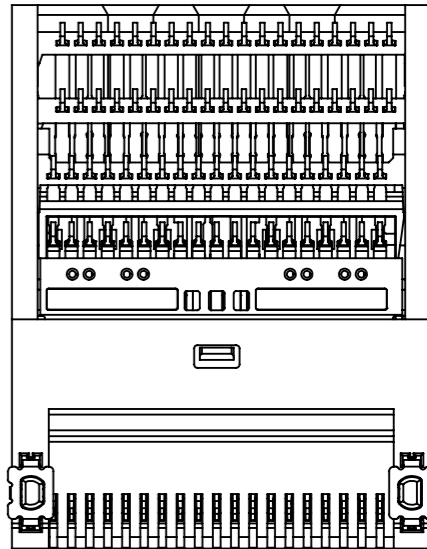

UE36-A1070-X000T  
(WITH SOLDER RINGS FOR BELLY TO BELLY MOUNTING)

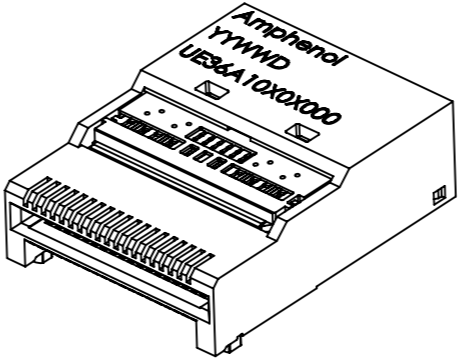

ISOMETRIC VIEW  
SCALE 2:1

**NOTES:**

- MATERIAL:** SOLDER PROCESS REFLOW COMPATIBLE LCP, UL 94 V-0  
**CONTACTS:** COPPER ALLOY. SEE PART NUMBER TREE FOR PLATING DETAILS
- RoHS COMPLIANT.
- PERFORMANCE:** 0.50A MAX. SIGNAL CONTACTS  
1.0A MAX. POWER CONTACTS  
**MECHANICAL:** 100 MATING CYCLES MIN.
- COMPLIES WITH QSFP-DD MSA.



**DATA CONTROL RELEASED**  
DEPT. NO. -- 634 --  
DATE: 19 JUL 2018

DO NOT SCALE DRAWING

THIS DOCUMENT CONTAINS PROPRIETARY INFORMATION AND SUCH INFORMATION MAY NOT BE DISCLOSED TO OTHERS FOR ANY PURPOSE OR USED FOR MANUFACTURING PURPOSES WITHOUT PERMISSION FROM AMPHENOL CANADA CORP.

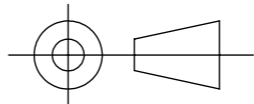

UNLESS OTHERWISE SPECIFIED DIMENSIONS ARE IN MILLIMETERS TOLERANCES ARE:		APPROVALS		DATE	Amphenol High Speed Interconnects A Division of Amphenol Corp. www.amphenol-highspeed.com		
DECIMALS	ANGLES	DRAWN	KEN W.	01/10/2018	TITLE		
X.X ± 0.25	± 3°	DESIGNED	HCL-VK	01/10/2018	QSFP-DD 1X1 SMT CONNECTOR PLUG ASSEMBLY		
X.XX ± 0.13		CHECKED	KEN W.	01/10/2018	0.8mm PITCH, 76-PIN		
MATERIAL AND FINISH		QA APP'D	JOE P.	01/10/2018	SIZE	DWG. NO.	REV.
SEE NOTES		IE APP'D	ANDY C.	01/10/2018	A3	P-UE36-A10X0-X000T	F
REF.	-	DWG APP'D	ARKADY Z.	01/10/2018	SCALE	PROJECT	SHEET
CODE IDENT. NO.	-				5:1	-	1 OF 4

8 7 6 5 4 3 2 1

REVISIONS						
ZONE	REV.	ECN	DESCRIPTION	BY	DATE	APPROVED
			SEE SHEET 1			

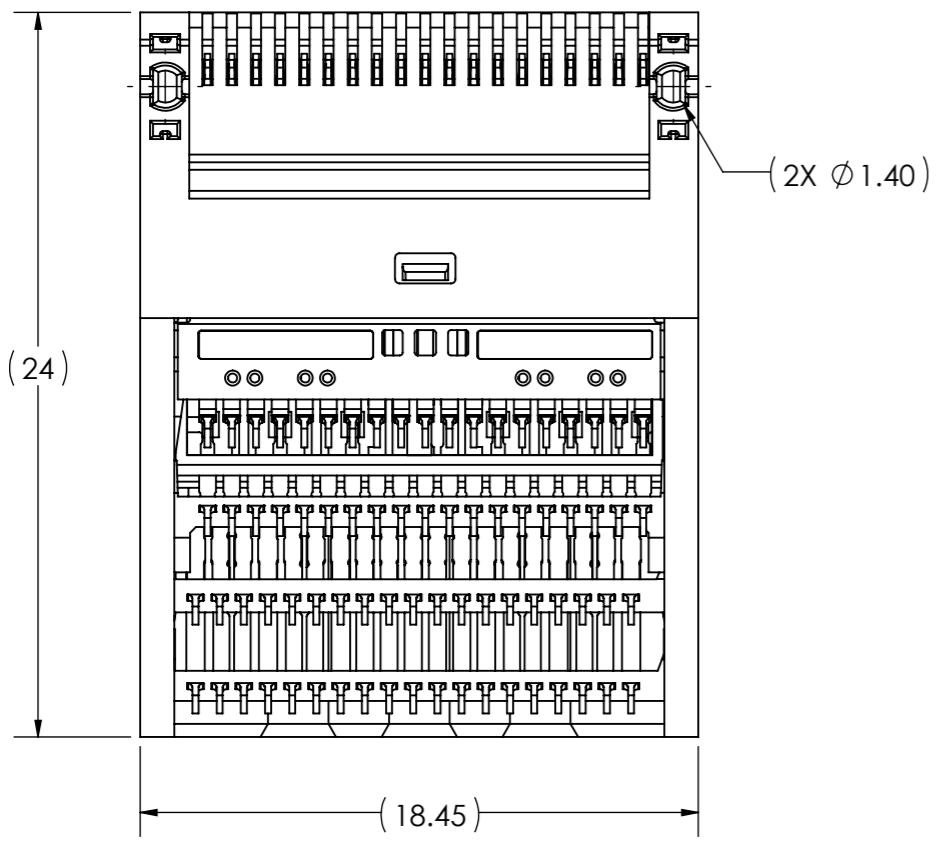
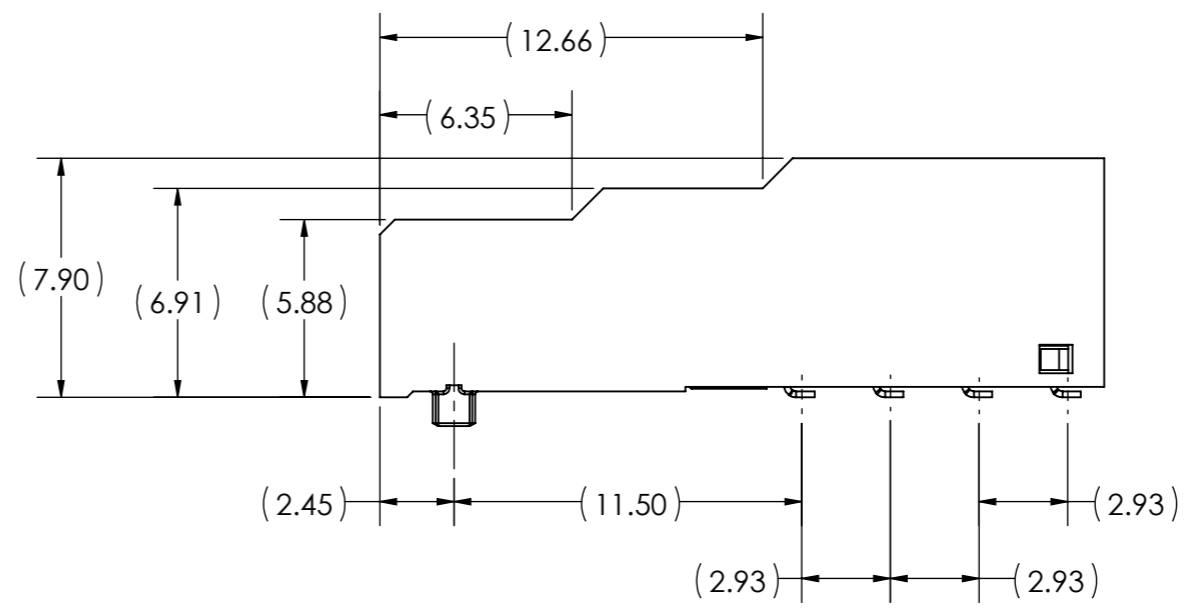
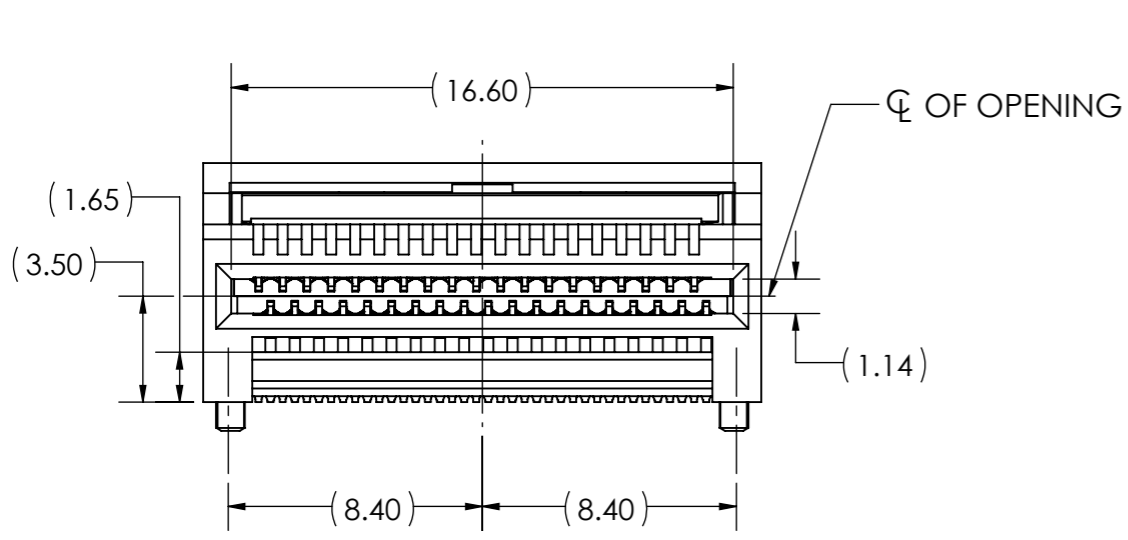

**DATA CONTROL  
RELEASED**  
 DEPT. NO. -- 634 --  
 DATE: 19 JUL. 2018

DO NOT SCALE DRAWING

THIS DOCUMENT CONTAINS PROPRIETARY INFORMATION AND SUCH INFORMATION MAY NOT BE DISCLOSED TO OTHERS FOR ANY PURPOSE OR USED FOR MANUFACTURING PURPOSES WITHOUT PERMISSION FROM AMPHENOL CANADA CORP.

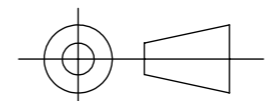

UNLESS OTHERWISE SPECIFIED DIMENSIONS ARE IN MILLIMETERS TOLERANCES ARE: DECIMALS            ANGLES X.X ± 0.25            ± 3° X.XX ± 0.13	APPROVALS	DATE	<b>Amphenol High Speed Interconnects</b> <small>A Division of Amphenol Corp. www.amphenol-highspeed.com</small> TITLE <b>QSFP-DD 1X1 SMT CONNECTOR PLUG ASSEMBLY</b> 0.8mm PITCH, 76-PIN
	DRAWN KEN W.	01/10/2018	
	DESIGNED HCL-VK	01/10/2018	
	CHECKED KEN W.	01/10/2018	
MATERIAL AND FINISH	QA APP'D JOE P.	01/10/2018	SIZE <b>A3</b> DWG. NO. P-UE36-A10X0-X000T REV. F SCALE 5:1 PROJECT - SHEET 2 OF 4
SEE NOTES	IE APP'D ANDY C.	01/10/2018	
REF. -	DWG APP'D ARKADY Z.	01/10/2018	
CODE IDENT. NO. -			

8 7 6 5 4

REVISIONS						
ZONE	REV.	ECN	DESCRIPTION	BY	DATE	APPROVED
			SEE SHEET 1			

DATA CONTROL  
RELEASED  
DEPT. NO. -- 634 --  
DATE: 19 JUL 2018

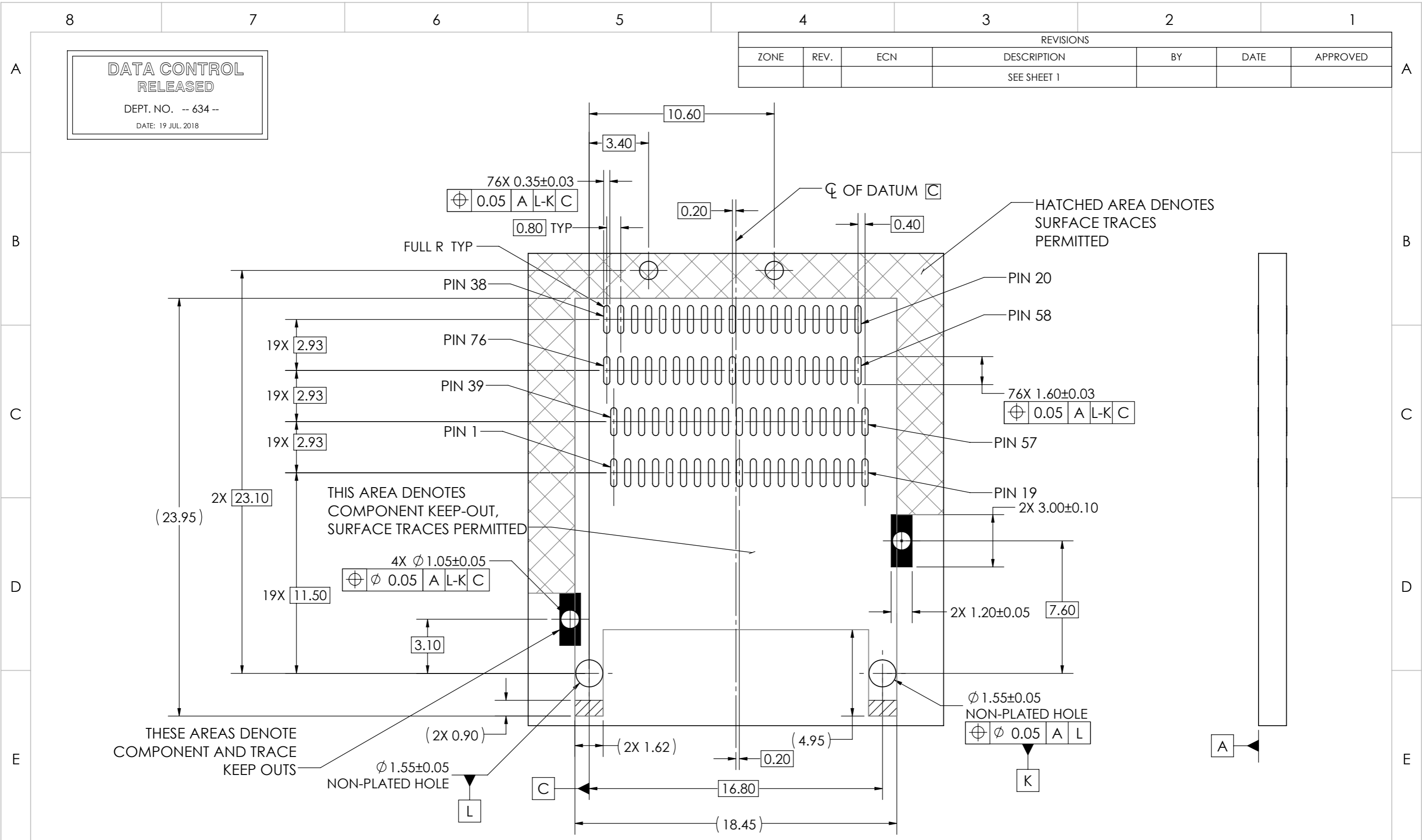

**RECOMMENDED PCB LAYOUT  
SINGLE-SIDED MOUNTING**

UNLESS OTHERWISE SPECIFIED DIMENSIONS ARE IN MILLIMETERS TOLERANCES ARE: DECIMALS X.X±0.25 X.XX±0.13 MATERIAL AND FINISH SEE NOTES REF. - CODE IDENT. NO. -	APPROVALS	DATE	Amphenol High Speed Interconnects A Division of Amphenol Corp. www.amphenol-highspeed.com TITLE QSFP-DD 1X1 SMT CONNECTOR PLUG ASSEMBLY 0.8mm PITCH, 76-PIN SIZE A3 DWG. NO. P-UE36-A10X0-X000T REV. F SCALE 5:1 PROJECT SHEET 3 OF 4
	DRAWN KEN W.	01/10/2018	
	DESIGNED HCL-VK	01/10/2018	
	CHECKED KEN W.	01/10/2018	
	QA APP'D JOE P.	01/10/2018	
	IE APP'D ANDY C.	01/10/2018	
	DWG APP'D ARKADY Z.	01/10/2018	

DO NOT SCALE DRAWING

THIS DOCUMENT CONTAINS PROPRIETARY INFORMATION AND SUCH INFORMATION MAY NOT BE DISCLOSED TO OTHERS FOR ANY PURPOSE OR USED FOR MANUFACTURING PURPOSES WITHOUT PERMISSION FROM AMPHENOL CANADA CORP.

