DisplayPort to TMDS Translator

FEATURES

- DisplayPort Physical Layer Input Port to TMDS Physical Layer Output Port
- Integrated TMDS Level Translator With Receiver Equalization
- Supports Data Rates up to 2.5 Gbps
- Integrated I²C Logic Block for DVI / HDMI Connector Recognition
- Integrated Active I²C Buffer
- Enhanced ESD: 12 kV on all Pins
- Enhanced Commercial Temperature Range: 0°C to 85°C
- 36 Pin 6 × 6 QFN Package

APPLICATIONS

- Personal Computer Market
 - DP/TMDS Hardware Key (Dongle)
 - Desktop PC
 - Notebook PC
 - Docking Station
 - Standalone Video Card

DESCRIPTION

The SN75DP129 is a Dual-Mode DisplayPort input to Transition-Minimized Differential Signaling (TMDS) output. The TMDS output has a built-in level translator, compliant with [Digital Visual Interface 1.0 \(DVI\)](#) and [High Definition Multimedia Interface 1.3 \(HDMI\)](#) standards. The SN75DP129 is specified up to a maximum data rate of 2.5 Gbps, supporting resolutions greater than 1920 x 1200 or HDTV 12-bit color depth at 1080p (progressive scan).

An integrated Active I²C buffer isolates the capacitive loading of the source system from that of the sink and interconnecting cable. This isolation improves overall signal integrity of the system and provides greater design margin within the source system for DVI / HDMI compliance testing.

A logic block was designed into the SN75DP129 to assist with TMDS connector identification. Through the use of the I²C_EN pin, this logic block can be enabled to indicate the translated port is an HDMI port; therefore legally supporting HDMI content.



Please be aware that an important notice concerning availability, standard warranty, and use in critical applications of Texas Instruments semiconductor products and disclaimers thereto appears at the end of this data sheet.



These devices have limited built-in ESD protection. The leads should be shorted together or the device placed in conductive foam during storage or handling to prevent electrostatic damage to the MOS gates.

TYPICAL APPLICATION

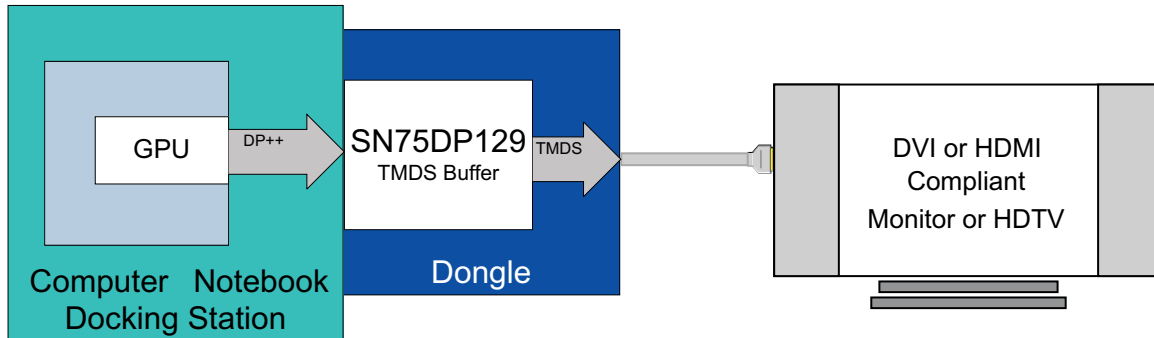

GPU—Graphics Processing Unit

DP++—Dual-Mode DisplayPort

TMDs—Transition-Minimized Differential Signaling

DVI—Digital Visual Interface

HDMI—High Definition Multimedia Interface

INTERNAL DATA CONNECTION DIAGRAM

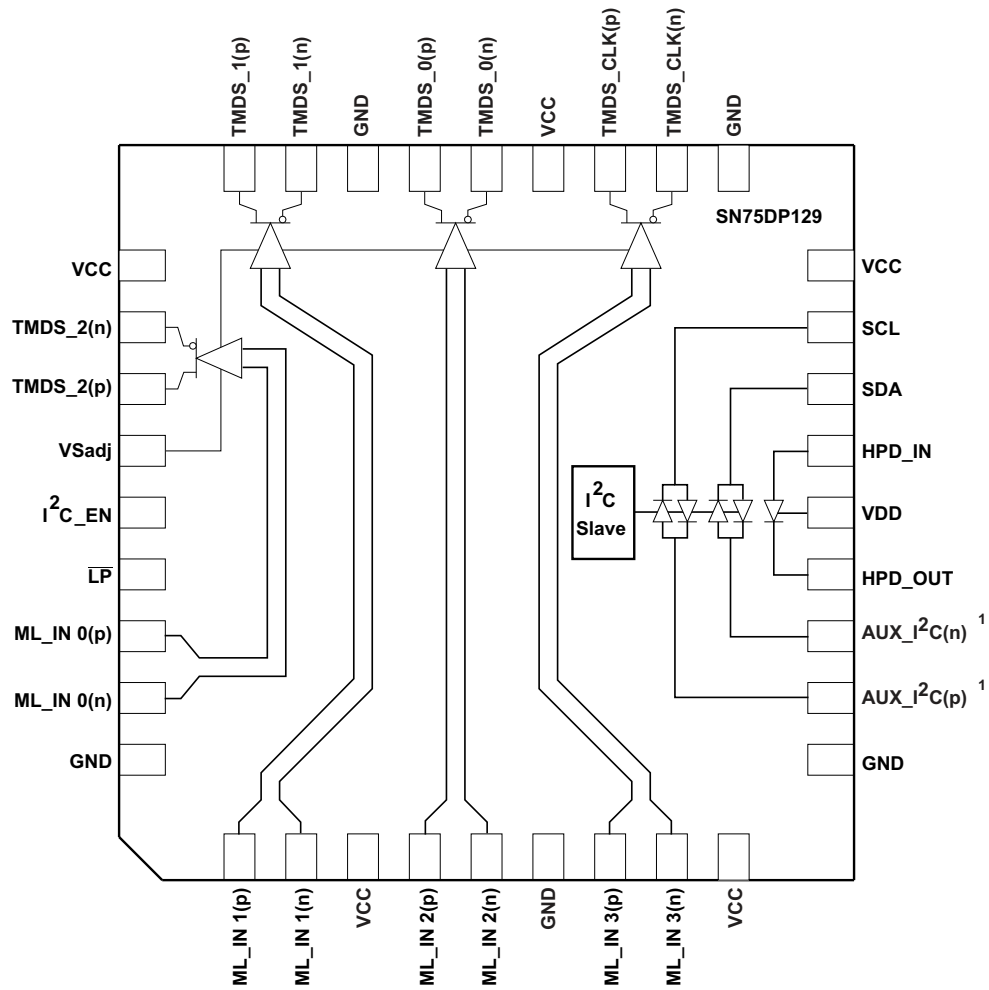

(1) I²C bus data (n-SDA) and clock (p-SCL) lines.

PIN CONFIGURATION

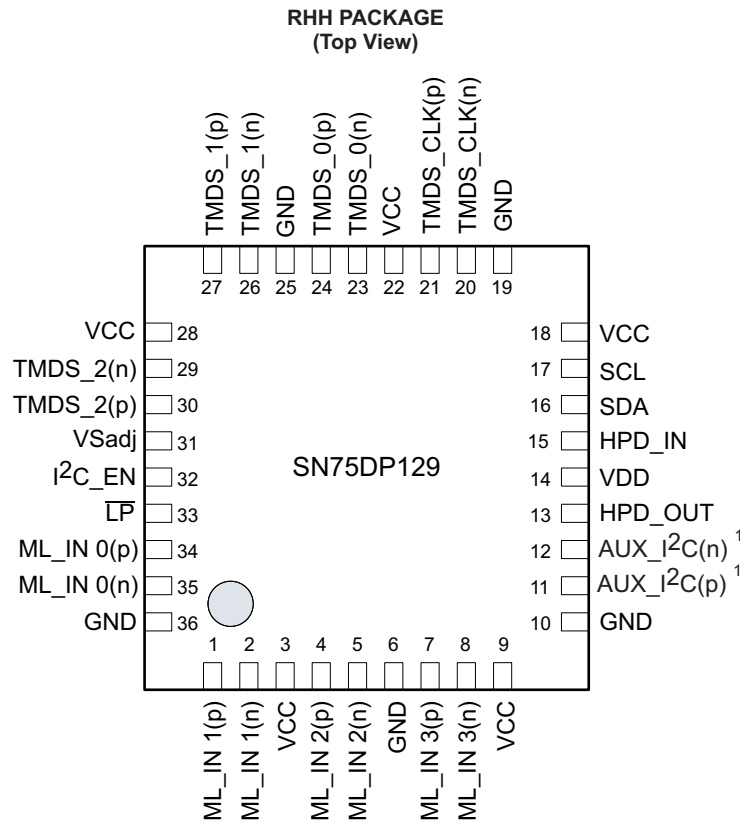

(1) I²C bus data (n-SDA) and clock (p-SCL) lines.

TERMINAL FUNCTIONS

TERMINAL		I/O	DESCRIPTION	TYPE
NAME	NO. ⁽¹⁾			
AUX_I ² C ⁽²⁾	11(p), 12(n)	I/O	Source Side Bidirectional DisplayPort Auxiliary Data Line	DDC LINK (Source)
GND	6, 10, 19, 25, 36		Ground	Ground
HPD_IN	15	I	Hot Plug Detect (HPD) Input	Hot Plug Detect
HPD_OUT	13	O	Hot Plug Detect (HPD) Output	Hot Plug Detect
I ² C_EN	32	I	Internal I ² C register enable, used for HDMI / DVI connector differentiation	Control
LP	33	I	Low Power Select Bar	Control
ML_IN 0	34(p), 35(n)	I	DisplayPort Main Link Channel 0 Differential Input	Main Link Input Pins
ML_IN 1	1(p), 2(n)	I	DisplayPort Main Link Channel 1 Differential Input	Main Link Input Pins
ML_IN 2	4(p), 5(n)	I	DisplayPort Main Link Channel 2 Differential Input	Main Link Input Pins
ML_IN 3	7(p), 8(n)	I	DisplayPort Main Link Channel 3 Differential Input	Main Link Input Pins
TMDS_2	30(p), 29(n)	O	TMDS Data 2 Differential Output	Main Link Output
TMDS_1	27(p), 26(n)	O	TMDS Data 1 Differential Output	Main Link Output
TMDS_0	24(p), 23(n)	O	TMDS Data 0 Differential Output	Main Link Output
TMDS_CLK	21(p), 20(n)	O	TMDS Data Clock Differential Output	Main Link Output
SCL	17	I/O	TMDS Port Bidirectional I ² C Clock Line	DDC Link (Sink)
SDA	16	I/O	TMDS Port Bidirectional I ² C Data Line	DDC Link (Sink)
VCC	3, 9, 18, 22, 28		3.3 V Supply	Voltage Supply

(1) (p) Positive; (n) Negative

(2) I²C bus data (n-SDA) and clock (p-SCL) lines.

TERMINAL FUNCTIONS (continued)

TERMINAL		I/O	DESCRIPTION	TYPE
NAME	NO. (1)			
VDD	14		HPD Supply	Voltage Supply
VSadj	31	I	TMDS-Compliant Voltage Swing Control	Reference

Input/Output Equivalent Circuits

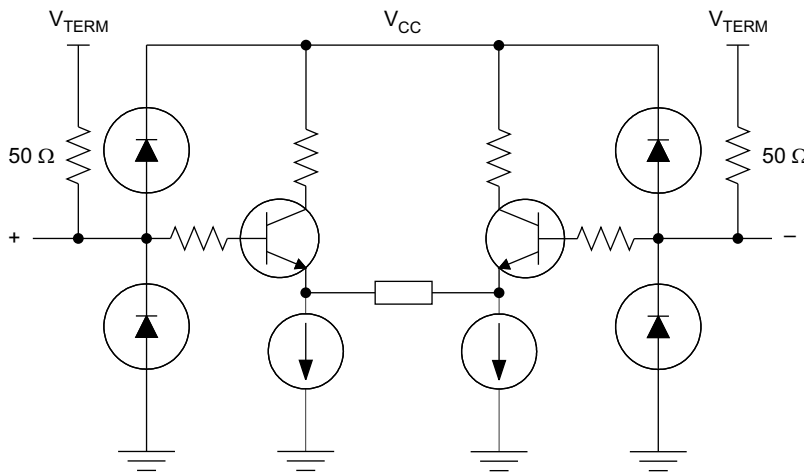

Figure 1. DisplayPort Input Stage

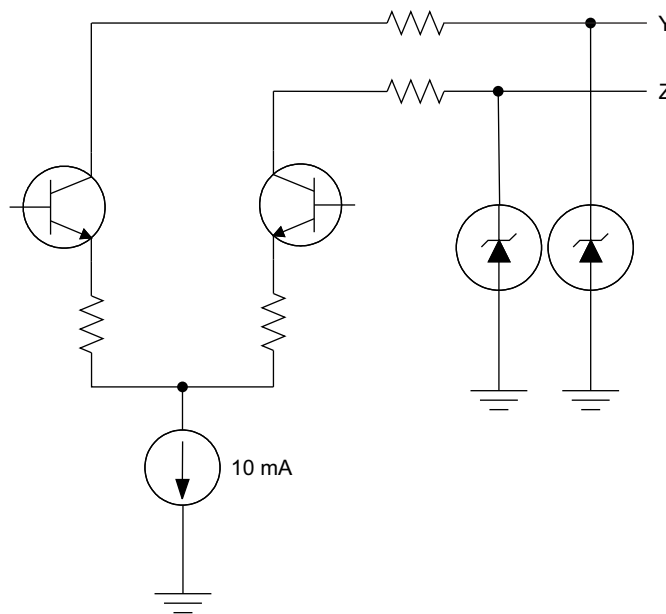

Figure 2. TMDS Output Stage

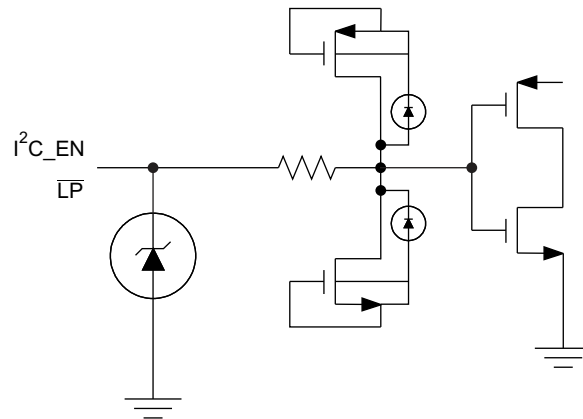

Figure 3. HPD and Control Input Stage

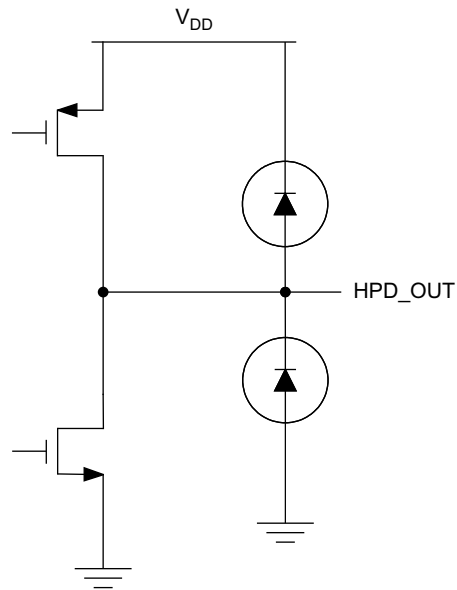

Figure 4. HPD Output Stage

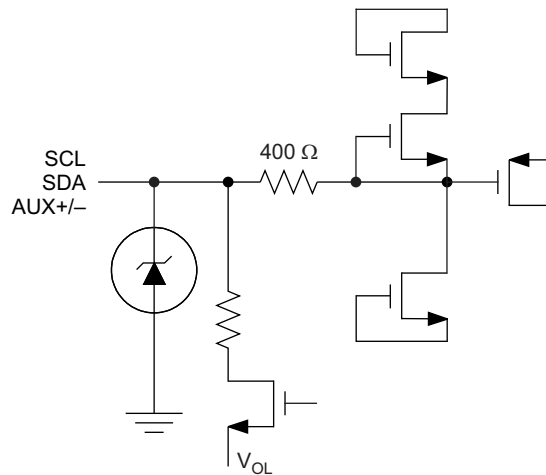

Figure 5. I²C Input and Output Stage

Table 1. Control Pin Lookup Table⁽¹⁾

SIGNAL	LEVEL	STATE	DESCRIPTION
LP	H	Normal Mode	Normal operational mode for device
	L	Low Power Mode	Device is forced into a Low Power state causing the outputs to go to a high impedance state. All other inputs are ignored.
I ² C_EN	H	HDMI	Internal I ² C register is active and readable, indicating the connector in use is HDMI-compliant.
	L	DVI	Internal I ² C register is disabled and unreadable, indicating the connector in use is DVI-compliant.
VS _{adj}	4.65 kΩ	Compliant Voltage Swing	Driver output voltage swing precision control to aid with system compliance.

(1) (H) Logic High; (L) Logic Low

ORDERING INFORMATION⁽¹⁾

PART NUMBER	PART MARKING	PACKAGE
SN75DP129RHHR	DP129	36-pin QFN Reel (large)
SN75DP129RHHT	DP129	36-pin QFN Reel (small)

(1) For the most current package and ordering information, see the Package Option Addendum at the end of this document, or see the TI web site at www.ti.com.

ABSOLUTE MAXIMUM RATINGS

over operating free-air temperature range (unless otherwise noted)⁽¹⁾

		VALUE	UNIT
Supply voltage range ⁽²⁾	VCC	-0.3 to 3.6	V
Supply voltage range	VDD	-0.3 to 3.6	V
Voltage range	Main link I/O (ML_IN x, DP_SINK x) differential voltage	1.5	V
	TMDS I/O	-0.3 to 4	V
	HPD I/O	-0.3 to 5.5	V
	Auxiliary I/O	-0.3 to 5.5	V
	Control I/O	-0.3 to 5.5	V
Electrostatic discharge	Human body model ⁽³⁾	±12000	V
	Charged-device model ⁽⁴⁾	±1000	V
	Machine model ⁽⁵⁾	±200	V
Continuous power dissipation		See Dissipation Ratings Table	

(1) Stresses beyond those listed under absolute maximum ratings may cause permanent damage to the device. These are stress ratings only and functional operation of the device at these or any conditions beyond those indicated under recommended operating conditions is not implied. Exposure to absolute-maximum-rated conditions for extended periods may affect device reliability.

(2) All voltage values, except differential voltages, are with respect to network ground terminal.

(3) Tested in accordance with JEDEC Standard 22, Test Method A114-B

(4) Tested in accordance with JEDEC Standard 22, Test Method C101-A

(5) Tested in accordance with JEDEC Standard 22, Test Method A115-A

DISSIPATION RATINGS

PACKAGE	PCB JEDEC STANDARD	T _A ≤ 25°C	DERATING FACTOR ⁽¹⁾ ABOVE T _A = 25°C	T _A = 85°C POWER RATING
36-pin QFN (RHH)	Low-K	1398 mW	13.98 mW/°C	559 mW
	High-K	2941 mW	29.41 mW/°C	1176 mW

(1) This is the inverse of the junction-to-ambient thermal resistance when board-mounted and with no air flow.

THERMAL CHARACTERISTICS

over operating free-air temperature range (unless otherwise noted)

PARAMETER		TEST CONDITIONS	MIN	TYP	MAX	UNIT
$R_{\theta JB}$	Junction-to-board thermal resistance			9.44 ⁽¹⁾		°C/W
$R_{\theta JC}$	Junction-to-case thermal resistance			24.74		°C/W
P_D	Device power dissipation ⁽²⁾	$\overline{LP} = 3.3$ V, ML: $V_{ID} = 500$ mV, 2.5 Gbps PRBS; I^2C : $V_{ID} = 3.3$ V, 100 Kbps PRBS; HPD = 5 V		380	490	mW
P_{SD}	Device power dissipation under low power	$\overline{LP} = 0$ V		5	20	μW

(1) The maximum rating is simulated under 3.6 V V_{CC} and V_{DD} unless otherwise noted.

(2) Power dissipation is the sum of the power consumption from the V_{CC} and V_{DD} pins, plus the 132 mW of power from the AVCC (Receiver Termination Supply).

RECOMMENDED OPERATING CONDITIONS

		MIN	NOM	MAX	UNIT
V_{CC}	Supply voltage	3	3.3	3.6	V
V_{DD}	Supply voltage	1.65		3.6	V
T_A	Operating free-air temperature	0		85	°C
MAIN LINK DIFFERENTIAL INPUT PINS					
V_{ID}	Peak-to-peak input differential voltage	0.15		1.40	V
d_R	Data rate			2.5	Gbps
TMDS DIFFERENTIAL OUTPUT PINS					
AV_{CC}	TMDS output termination voltage	3	3.3	3.6	V
d_R	Data rate			2.5	Gbps
R_t	Termination resistance	45	50	55	Ω
AUXILIARY AND I²C PINS					
V_I	Input voltage	0		5.5	V
$d_{R(I2C)}$	I ² C data rate			100	kHz
HPD AND CONTROL PINS					
V_{IH}	High-level input voltage	2		5.5	V
V_{IL}	Low-level input voltage	0		0.8	V

Device Power

The SN75DP129 is designed to operate from one or two supply voltages, depending on the implementation of the integrated Hot Plug Detect (HPD) level translator. The TMDS level translator is powered from a single 3.3-V supply. The HPD translator is powered using the VDD pin and its voltage can range from 1.8 V to 3.3 V. This voltage determines the HIGH-level output voltage of the HPD_OUT pin.

ELECTRICAL CHARACTERISTICS

over recommended operating conditions (unless otherwise noted)

PARAMETER		TEST CONDITIONS	MIN	TYP	MAX	UNIT
I_{CC}	Supply current	$LP = 3.6$ V, $V_{CC} = V_{DD}$, ML: $V_{ID} = 500$ mV, 2.7 Gbps PRBS	50	75	112	mA
I_{DD}	Supply current	AUX: $V_I = 3.3$ V, 100 kHz PRBS HPD: HPD_IN = 5 V		1	2	mA
I_{SD}	Shutdown current	$\overline{LP} = 0$ V		1	5	μA

Hot Plug and Cable Adapter Detect

The SN75DP129 has a built-in level shifter for the HPD outputs. The output voltage level of the HPD pin is defined by the voltage level of the VDD pin.

ELECTRICAL CHARACTERISTICS

over recommended operating conditions (unless otherwise noted)

PARAMETER	TEST CONDITIONS	MIN	TYP	MAX	UNIT
$V_{OH3.3}$	High-level output voltage $I_{OH} = -100 \mu A, V_{DD \times 1} = 3.3 V$	3		3.3	V
$V_{OH2.5}$		2.25		2.5	V
$V_{OH1.8}$		1.62		1.8	V
V_{OL}	Low-level output voltage $I_{OH} = 100 \mu A$	0		0.4	V
I_H	High-level input current $V_{IH} = 2.0 V, V_{DD} = 3.6 V$	-10		10	μA
I_L	Low-level input current $V_{IL} = 0.8 V, V_{DD} = 3.6 V$	-10		10	μA

SWITCHING CHARACTERISTICS

over recommended operating conditions (unless otherwise noted)

PARAMETER	TEST CONDITIONS	MIN	TYP	MAX	UNIT
$t_{PD(HPD)}$	Propagation delay $V_{DD} = 3.6 V$	5		30	ns

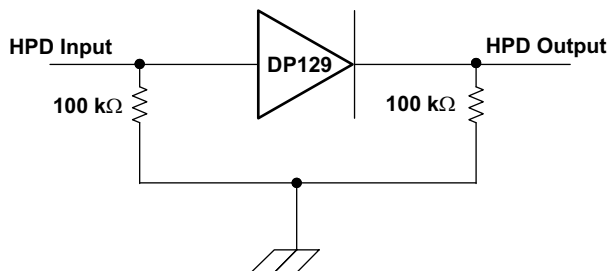

Figure 6. HPD Test Circuit

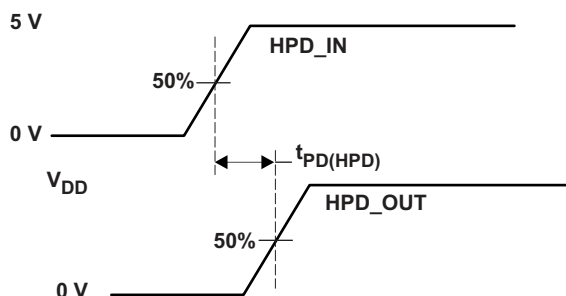

Figure 7. HPD Timing Diagram

AUX / I²C Pins

The SN75DP129 utilizes an active I²C repeater. The repeater isolates the parasitic effects of the system to aid with system level compliance.

In addition to the I²C repeater, the SN75DP129 supports the connector detection I²C register. This register is enabled using the I2C_EN pin. When active, an internal memory register is readable using the AUX_I²C pins. This I²C register block functionality is described in the [APPLICATION INFORMATION](#) section.

ELECTRICAL CHARACTERISTICS

over recommended operating conditions (unless otherwise noted)

PARAMETER		TEST CONDITIONS	MIN	TYP	MAX	UNIT
I_L	Low input current	$V_{CC} = 3.6\text{ V}$, $V_I = 0\text{ V}$	-10		10	μA
$I_{ikg(AUX)}$	Input leakage current	AUX_I ² C pins $V_{CC} = 3.6\text{ V}$, $V_I = 3.6\text{ V}$	-10		10	μA
$C_{IO(AUX)}$	Input/output capacitance	AUX_I ² C pins DC bias = 1.65 V, AC = 2.1 V _{p-p} , f = 100 kHz			15	pF
$V_{IH(AUX)}$	High-level input voltage	AUX_I ² C pins	1.6		5.5	V
$V_{IL(AUX)}$	Low-level input voltage	AUX_I ² C pins	-0.2		0.4	V
$V_{OL(AUX)}$	Low-level output voltage	AUX_I ² C pins $I_O = 4\text{ mA}$	0.5		0.6	V
$I_{ikg(I2C)}$	Input leakage current	I ² C SDA/SCL pins $V_{CC} = 3.6\text{ V}$, $V_I = 4.95\text{ V}$	-10		10	μA
$C_{IO(I2C)}$	Input/output capacitance	I ² C SDA/SCL pins DC bias = 2.5 V, AC = 3.5 V _{p-p} , f = 100 kHz			15	pF
$V_{IH(I2C)}$	High-level input voltage	I ² C SDA/SCL pins	2.1		5.5	V
$V_{IL(I2C)}$	Low-level input voltage	I ² C SDA/SCL pins	-0.2		1.5	V
$V_{OL(I2C)}$	Low-level output voltage	I ² C SDA/SCL pins $I_O = 4\text{ mA}$			0.2	V

SWITCHING CHARACTERISTICS

over recommended operating conditions (unless otherwise noted)

PARAMETER		TEST CONDITIONS	MIN	TYP	MAX	UNIT
t_{PLH1}	Propagation delay time, low to high	Source to Sink	204		459	ns
t_{PHL1}	Propagation delay time, high to low	Source to Sink	35		200	ns
t_{PLH2}	Propagation delay time, low to high	Sink to Source	80		251	ns
t_{PHL2}	Propagation delay time, high to low	Sink to Source	35		200	ns
t_{f1}	Output signal fall time	Sink Side	20		72	ns
t_{f2}	Output signal fall time	Source Side	20		72	ns
f_{SCL}	SCL clock frequency for internal register	Source Side			100	kHz
$t_{W(L)}$	Clock LOW period for I ² C register	Source Side	4.7			μs
$t_{W(H)}$	Clock HIGH period for internal register	Source Side	4.0			μs
t_{SU1}	Internal register setup time, SDA to SCL	Source Side	250			ns
$t_{h(1)}$	Internal register hold time, SCL to SDA	Source Side	0			μs
$t_{(buf)}$	Internal register bus free time between STOP and START	Source Side	4.7			μs
$t_{SU(2)}$	Internal register setup time, SCL to START	Source Side	4.7			μs
$t_{h(2)}$	Internal register hold time, START to SCL	Source Side	4.0			μs
$t_{SU(3)}$	Internal register hold time, SCL to STOP	Source Side	4.0			μs

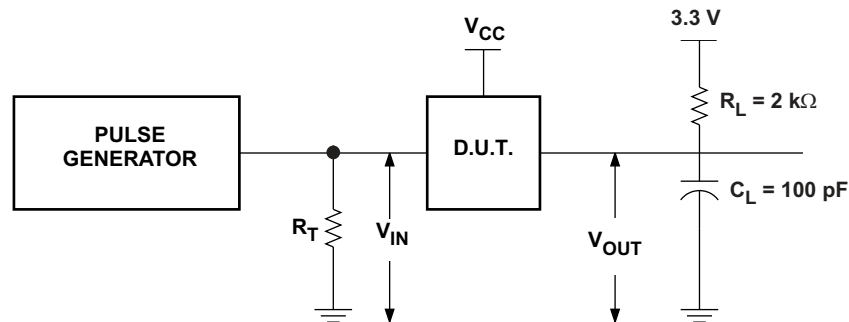

Figure 8. Source Side Test Circuit (AUX_I²C)

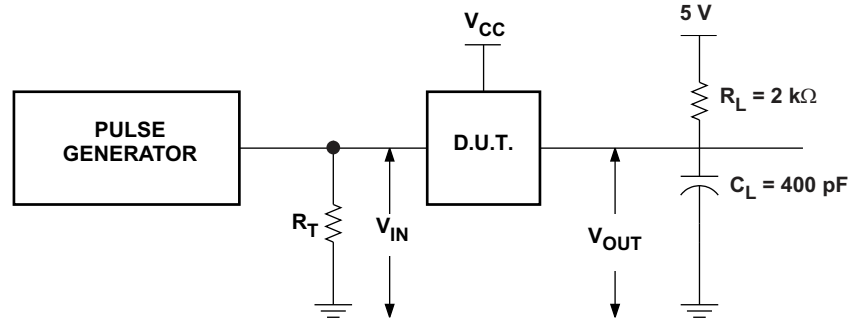

Figure 9. Sink Side Test Circuit (SCL, SDA)

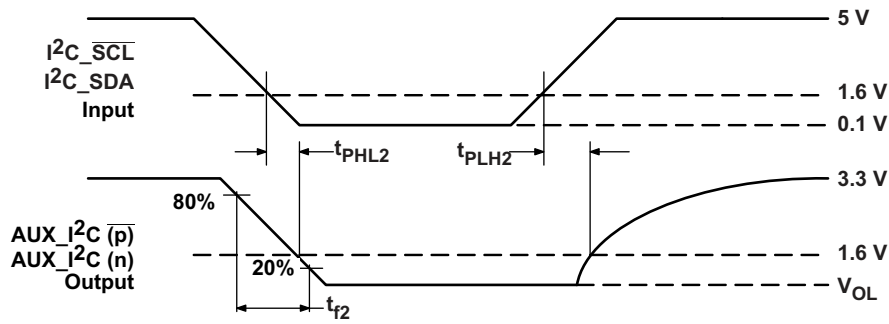

Figure 10. Source Side Output AC Measurements

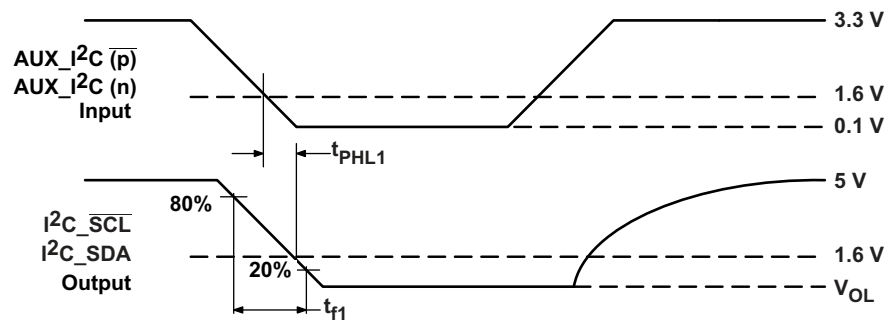

Figure 11. Sink Side Output AC Measurements

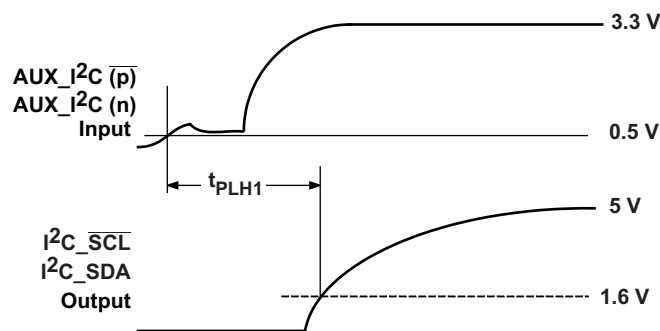

Figure 12. Sink Side Output AC Measurements (continued)

TMDS and Main Link Pins

The main link inputs are designed to be compliant with the DisplayPort 1.1 specification. The TMDS outputs of the SN75DP129 are designed to be compliant with the Digital Visual Interface 1.0 (DVI) and High Definition Multimedia Interface 1.3 (HDMI) specifications. The differential output voltage swing can be fine-tuned with the VSadj (TMDS-compliant Voltage Swing Control) resistor.

ELECTRICAL CHARACTERISTICS

over recommended operating conditions (unless otherwise noted)

PARAMETER		TEST CONDITIONS	MIN	TYP	MAX	UNIT
V _{OH}	Single-ended HIGH level output voltage	AVCC = 3.3 V, R _T = 50 Ω	AVCC–10		AVCC+10	mV
V _{OL}	Single-ended LOW level output voltage		AVCC–600		AVCC–400	mV
V _{SWING}	Single-ended output voltage swing		400		600	mV
V _{OC(SS)}	Change in steady-state common-mode output voltage between logic states		–5		5	mV
V _{OD(PP)}	Peak-to-peak output differential voltage		800		1200	mV
V _{(O)SBY}	Single-ended standby output voltage	AVCC = 3.3 V, R _T = 50 Ω, LP = 0	AVCC–10		AVCC+10	mV
I _{(O)OFF}	Single-ended power down output current	0 V ≤ V _{CC} ≤ 1.5 V, AVCC = 3.3 V, R _T = 50 Ω	–10		10	μA
I _{OS}	Short circuit output current	V _{ID} = 500 mV	–15		15	mA
R _{INT}	Input termination impedance		45	50	55	Ω
V _{term}	Input termination voltage		1		2	V

SWITCHING CHARACTERISTICS

over recommended operating conditions (unless otherwise noted)

PARAMETER		TEST CONDITIONS	MIN	TYP	MAX	UNIT
t _{PLH}	Propagation delay time	AVCC = 3.3 V, R _T = 50 Ω, f = 1 MHz	250	350	600	ps
t _{PHL}	Propagation delay time		250	350	600	ps
t _R	Rise time		60	90	140	ps
t _F	Fall time		60	90	140	ps
t _{SK(P)}	Pulse skew			8	15	ps
t _{SK(D)}	Intra-pair skew			20	40	ps
t _{SK(O)}	Inter-pair skew			20	65	ps
t _{JITD(PP)}	Peak-to-peak output residual data jitter	AVCC = 3.3 V, R _T = 50 Ω, dR = 2.5 Gbps		14	50	ps
t _{JITC(PP)}	Peak-to-peak output residual clock jitter	AVCC = 3.3 V, R _T = 50 Ω, f = 250 MHz		8	30	ps

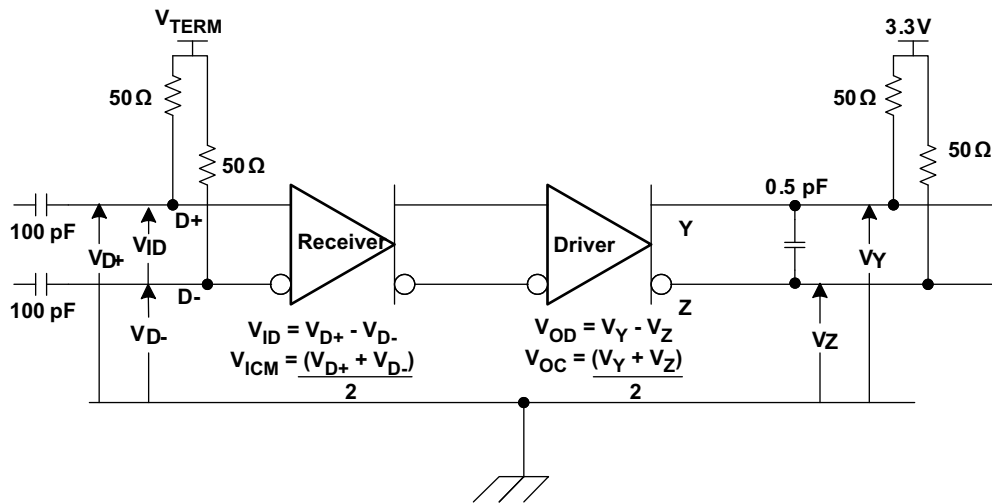

Figure 13. TMS Main Link Test Circuit

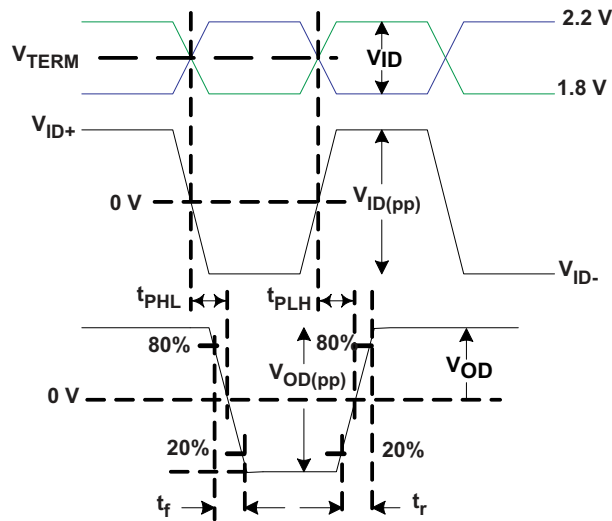

Figure 14. TMS Main Link Timing Measurements

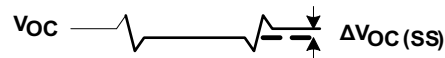
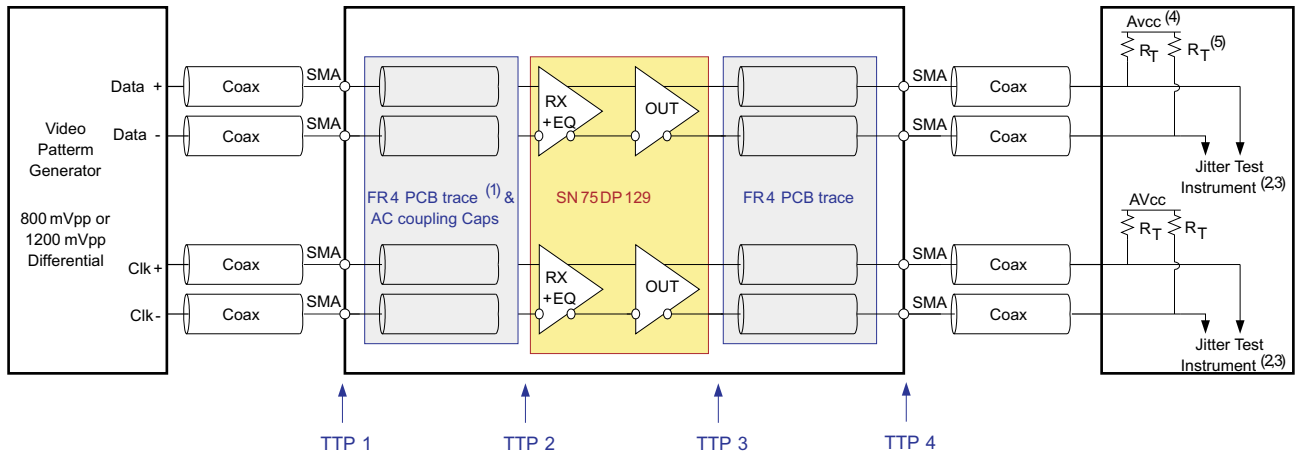

Figure 15. TMS Main Link Common Mode Measurements



- (1) The FR4 trace between TTP1 and TTP2 is designed to emulate 8 inches of FR4, a connector, and another 8 inches of FR4.
- (2) All jitter is measured at a BER of 10^{-12}
- (3) Residual jitter reflects the total jitter measured at TTP4 minus the jitter measured at TTP1.
- (4) AVCC = 3.3 V
- (5) $R_T = 50 \Omega$

Figure 16. TMD5 Jitter Measurements

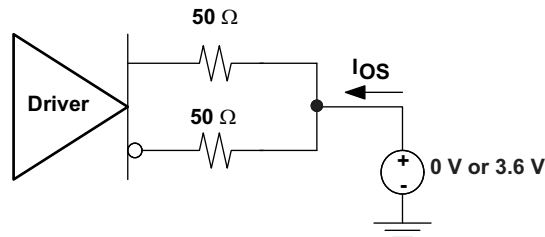

Figure 17. TMD5 Main Link Short Circuit Output Circuit

TYPICAL CHARACTERISTICS

Power dissipation is the sum of the power consumption from the VCC and VDD pins, plus the 132 mW of power from the AVCC (Receiver Termination Supply).

**POWER DISSIPATION
vs
DATA RATE**

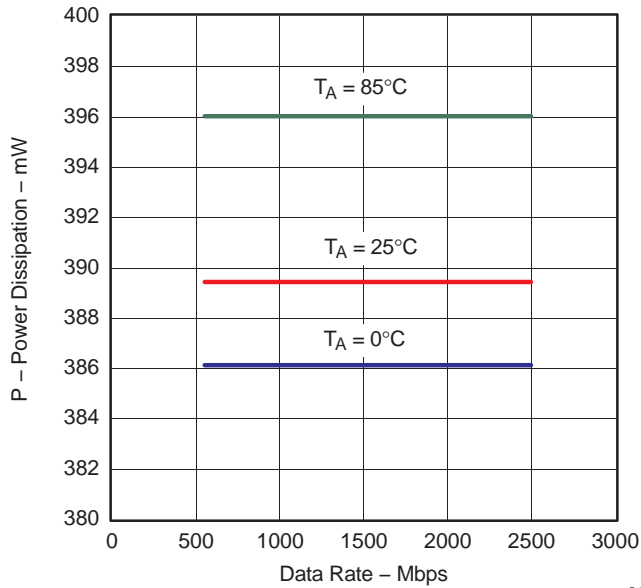

Figure 18.

**PEAK-TO-PEAK RESIDUAL DATA JITTER (at 2.5 Gbps)
vs
SUPPLY VOLTAGE**

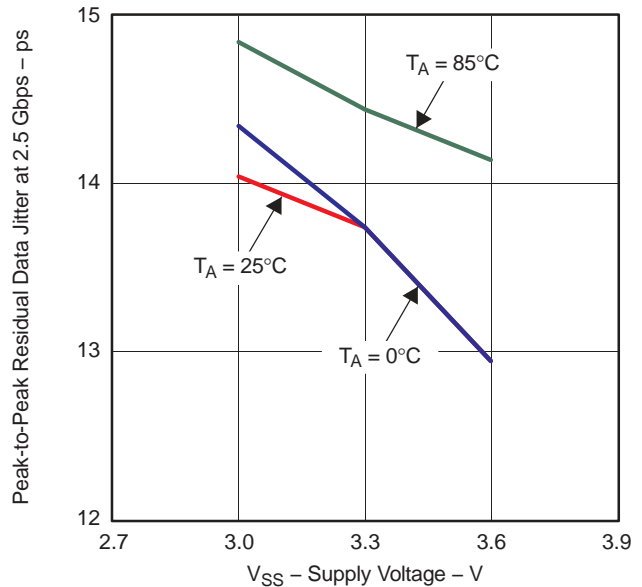

Figure 19.

**PEAK-TO-PEAK RESIDUAL DATA JITTER
vs
DATA RATE**

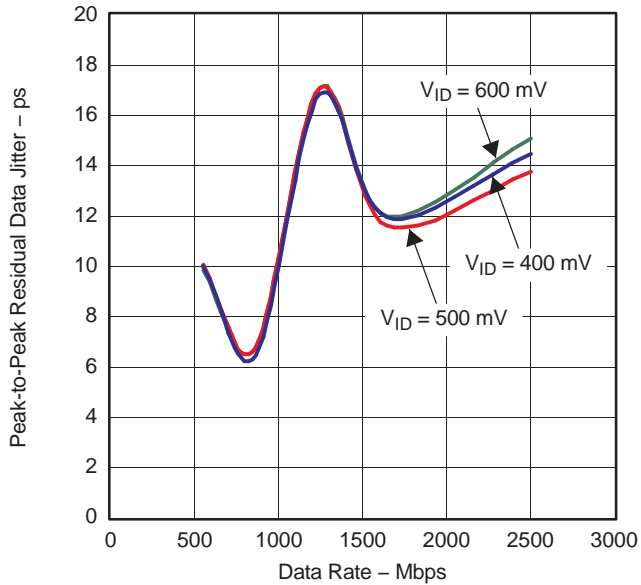

Figure 20.

**GAIN
vs
FREQUENCY**

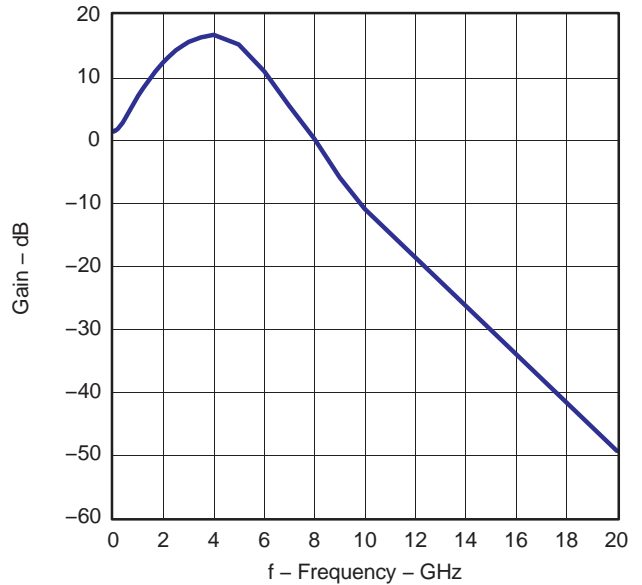

Figure 21.

TYPICAL CHARACTERISTICS (continued)

Power dissipation is the sum of the power consumption from the VCC and VDD pins, plus the 132 mW of power from the AVCC (Receiver Termination Supply).

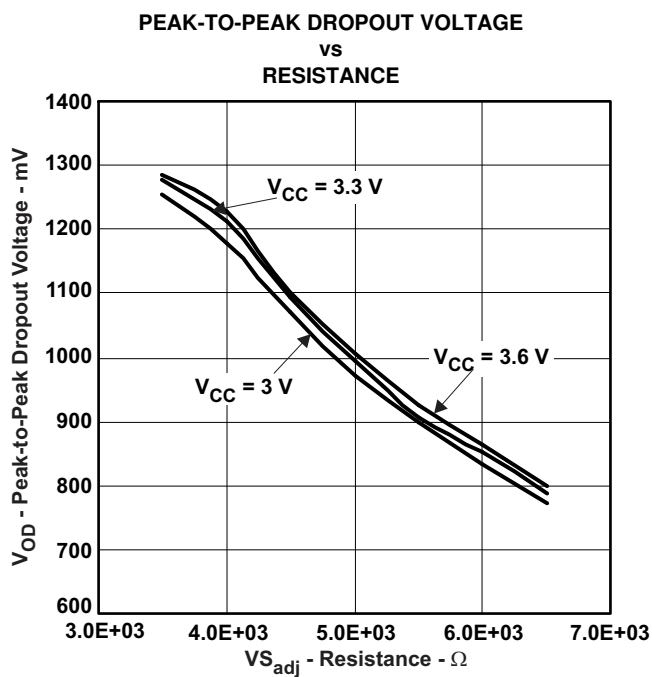

Figure 22.

APPLICATION INFORMATION

I²C INTERFACE NOTES

The I²C interface can access the internal memory of the SN75DP129. I²C is a two-wire serial interface developed by Philips Semiconductor (see [I²C-Bus Specification, Version 2.1, January 2000](#)). The bus consists of a data line (SDA) and a clock line (SCL) with pull-up structures. When the bus is *idle*, both SDA and SCL lines are pulled high. All the I²C compatible devices connect to the I²C bus through open drain I/O pins, SDA and SCL. A *master* device, usually a microcontroller or a digital signal processor, controls the bus. The master is responsible for generating the SCL signal and device addresses. The master also generates specific conditions that indicate the START and STOP of data transfer. A *slave* device receives and/or transmits data on the bus under control of the master device. The SN75DP129 works as a slave and supports the standard mode transfer (100 kbps) as defined in the I²C-Bus Specification.

The basic I²C start and stop access cycles are shown in [Figure 23](#).

The basic access cycle consists of the following:

- A start condition
- A slave address cycle
- Any number of data cycles
- A stop condition

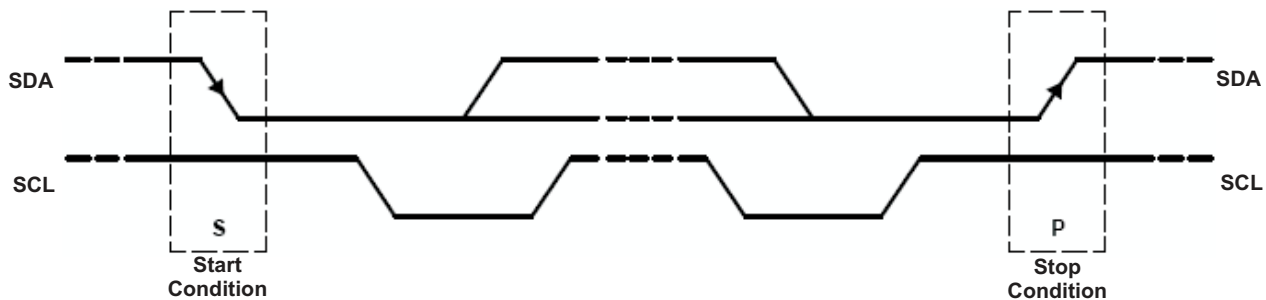

Figure 23. I²C Start and Stop Conditions

GENERAL I²C PROTOCOL

- The master initiates data transfer by generating a *start condition*. The *start condition* is when a high-to-low transition occurs on the SDA line the SCL line is high, as shown in [Figure 25](#). All I²C-compliant devices should recognize a *start condition*.
- The master generates the SCL pulses and transmits the 7-bit address and the *read/write direction bit* R/W on the SDA line. During all transmissions, the master ensures that data is *valid*. A *valid data condition* requires the SDA line to be stable during the entire high period of the clock pulse (see [Figure 24](#)). All devices recognize the address sent by the master and compare it to their internal fixed addresses. Only the slave device with a matching address generates an *acknowledge* (see [Figure 25](#)) by pulling the SDA line low during the entire high period of the ninth SCL cycle. On detecting this acknowledge, the master knows that a communication link with a slave has been established.
- The master generates further SCL cycles to transmit data to the slave (R/W bit 0) or *receive* data from the slave (R/W bit 1). In either case, the *receiver* needs to acknowledge the data sent by the *transmitter*. So an acknowledge signal can either be generated by the master or by the slave, depending on which one is the receiver. The 9-bit valid data sequences consisting of 8-bit data and 1-bit acknowledge can continue as long as necessary (see [Figure 26](#)).
- To signal the end of the data transfer, the master generates a *stop condition* by pulling the SDA line from low to high while the SCL line is high (see [Figure 26](#)). This releases the bus and stops the communication link with the addressed slave. All I²C compatible devices must recognize the stop condition. Upon the receipt of a *stop condition*, all devices know that the bus is released, and they wait for a *start condition*, followed by a matching address.

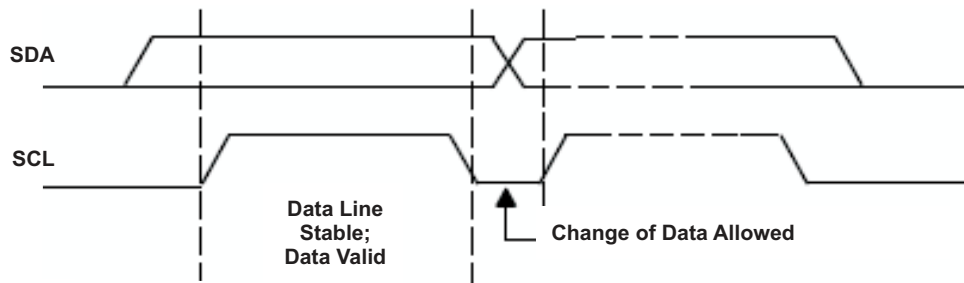

Figure 24. I²C Bit Transfer

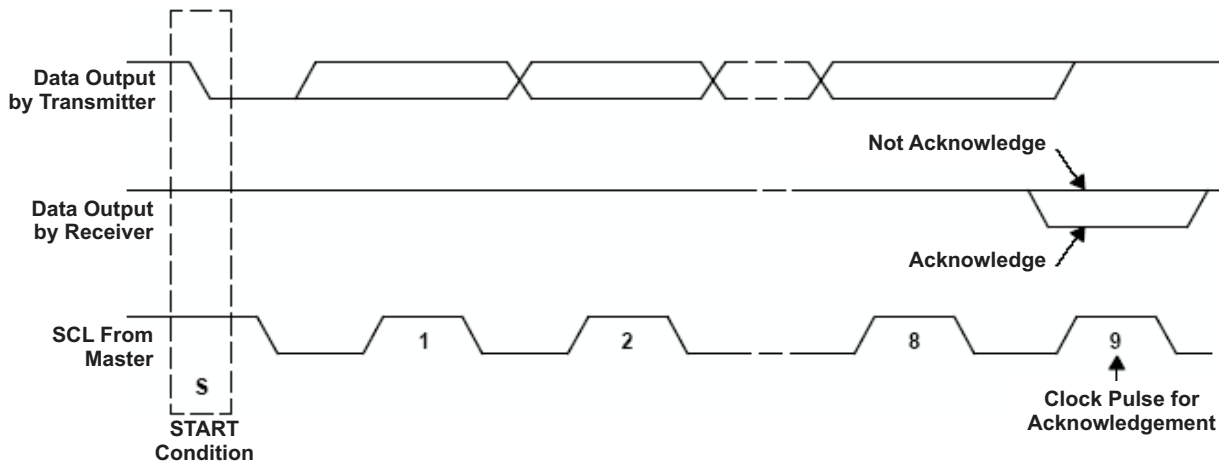

Figure 25. I²C Acknowledge

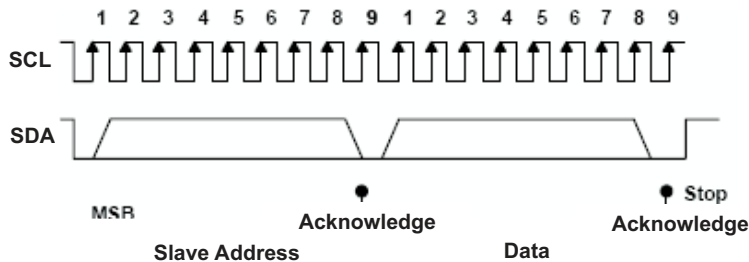

Figure 26. I²C Address and Data Cycles

During a read cycle, the slave receiver acknowledges the initial address byte if it decodes the address as its address. Following this initial acknowledge by the slave, the master device becomes a receiver and acknowledges data bytes sent by the slave. When the master has received all of the requested data bytes from the slave, the not acknowledge (A) condition is initiated by the master by keeping the SDA signal high just before it asserts the stop (P) condition. This sequence terminates a read cycle as shown in Figure 27 and Figure 28. See the [Reading from the SN75DP129, an example](#) section for more information.

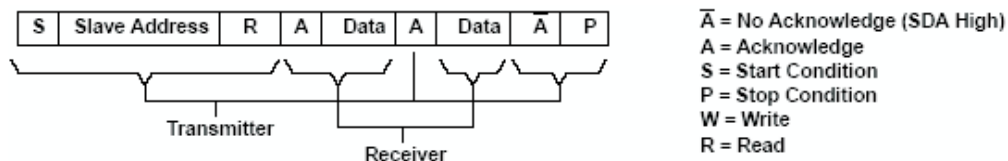

Figure 27. I²C Read Cycle

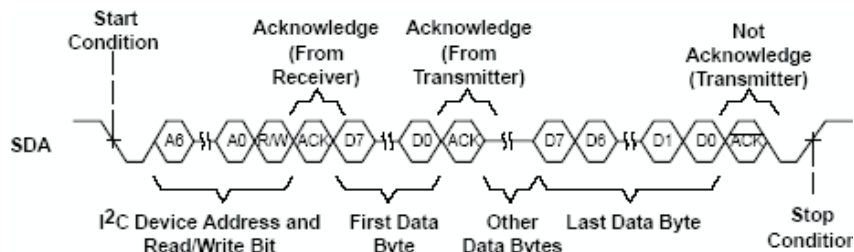

Figure 28. Multiple Byte Read Transfer

Slave Address

Both SDA and SCL must be connected to a positive supply voltage via a pull-up resistor. These resistors should comply with the I²C specification that ranges from 2 kΩ to 19 kΩ. When the bus is free, both lines are high. The address byte is the first byte received following the START condition from the master device. The 7 bit address is factory preset to 1000000. Table 2 lists the calls that the SN75DP129 will respond to.

Table 2. SN75DP129 Slave Address

FIXED ADDRESS							READ/WRITE BIT
BIT 7 (MSB)	BIT 6	BIT 5	BIT 4	BIT 3	BIT 2	BIT 1	BIT 0 (R/W)
1	0	0	0	0	0	0	1

Sink Port Selection Register and Source Plug-In Status Register Description (Sub-Address)

The SN75DP129 operates using a multiple byte transfer protocol similar to Figure 28. The internal memory of the SN75DP129 contains the phrase *DP-HDMI ADAPTOR<EOT>* converted to ASCII characters. The internal memory address registers and the corresponding values can be found in Table 3.

During a read cycle, the SN75DP129 sends the data (within its selected sub-address) in a single transfer to the master device requesting the information. See the [Reading from the SN75DP129, an Example](#) section of this data sheet for the proper procedure.

Table 3. SN75DP129 Sink Port and Source Plug-In Status Registers Selection

ADDRESS	0x00	0x01	0x02	0x03	0x04	0x05	0x06	0x07	0x08	0x09	0x0A	0x0B	0x0C	0x0D	0x0E	0x0F	0x10
Data	44	50	2D	48	44	4D	49	20	41	44	41	50	54	4F	52	04	FF

READING FROM THE SN75DP129, AN EXAMPLE

The read operation consists of several steps. The I²C master begins the communication with the transmission of the start sequence, followed by the slave address of the SN75DP129 and logic address of **00h**. The SN75DP129 acknowledges its presence to the master and begins to transmit the memory registers contents. After each byte is transferred, the SN75DP129 waits for an acknowledge (ACK) or a not-acknowledge (NACK) from the master. If an ACK is received, the next byte of data is transmitted. If a NACK is received, the data transmission sequence is expected to end and the master should send the stop command.

The SN75DP129 continues to send data until the master fails to acknowledge each byte transmission. If an ACK is received after the transmission of byte **0x0F**, the SN75DP129 transmits byte **0x10** and continues to transmit byte **0x10** for all further ACK's until a NACK is received.

SN75DP129 Read Phase

Step 1⁽¹⁾	0
I ² C Start (Master)	S

(1) The SN75DP129 also supports an accelerated read mode in which steps 1 through 6 can be skipped.

Step 2	7	6	5	4	3	2	1	0
I ² C General Address Write (Master)	1	0	0	0	0	0	0	0

Step 3	9
I ² C Acknowledge (Slave)	A

Step 4	7	6	5	4	3	2	1	0
I ² C Logic Address (Master)	1	0	0	0	0	0	0	0

Step 5	9
I ² C Acknowledge (Slave)	A

Step 6	0
I ² C Stop (Master)	P

Step 7	0
I ² C Start (Master)	S

Step 8	7	6	5	4	3	2	1	0
I ² C General Address Read (Master)	1	0	0	0	0	0	0	1

Step 9	9
I ² C Acknowledge (Slave)	A

Step 10	7	6	5	4	3	2	1	0
I ² C Read Data (Slave)	Data	Data	Data	Data	Data	Data	Data	Data

Where Data is determined by the Logic values Contained in the Sink Port Register

Step 11	9
I ² C Not-Acknowledge (Master)	X

Where X is an A (Acknowledge) or \bar{A} (Not-Acknowledge)

An A causes the pointer to increment and step 10 is repeated.

An \bar{A} causes the slave to stop transmitting and proceeds to step 12.

Step 12	0
I ² C Stop (Master)	P

Revision History

Changes from Original (January 2008) to Revision A	Page
• Changed device power dissipation from 250 mW typ to 380 mW typ.....	8
• Changed device power dissipation from 400 mW max to 490 mW max.....	8
• Changed propagation delay time, high to low, sink to source from 140 ns max to 200 ns max.....	10
• Changed t_{PHL1} to t_{PLH1} in Figure 12	11
• Changed t_{PHL} propagation delay time from 800 ps max to 600 ps max.....	12
• Changed $t_{JITD(PP)}$ peak-to-peak output residual data jitter from 20 ps typ to 14 ps typ.....	12
• Changed $t_{JITC(PP)}$ peak-to-peak output residual clock jitter from 10 ps typ to 8 ps typ.....	12
• Added peak-to-peak dropout voltage vs resistance curves.....	16

PACKAGING INFORMATION

Orderable Device	Status (1)	Package Type	Package Drawing	Pins	Package Qty	Eco Plan (2)	Lead finish/ Ball material (6)	MSL Peak Temp (3)	Op Temp (°C)	Device Marking (4/5)	Samples
SN75DP129RHHR	ACTIVE	VQFN	RHH	36	2500	RoHS & Green	NIPDAU	Level-3-260C-168 HR	0 to 85	DP129	Samples
SN75DP129RHHT	ACTIVE	VQFN	RHH	36	250	RoHS & Green	NIPDAU	Level-3-260C-168 HR	0 to 85	DP129	Samples

(1) The marketing status values are defined as follows:

ACTIVE: Product device recommended for new designs.

LIFEBUY: TI has announced that the device will be discontinued, and a lifetime-buy period is in effect.

NRND: Not recommended for new designs. Device is in production to support existing customers, but TI does not recommend using this part in a new design.

PREVIEW: Device has been announced but is not in production. Samples may or may not be available.

OBSOLETE: TI has discontinued the production of the device.

(2) **RoHS:** TI defines "RoHS" to mean semiconductor products that are compliant with the current EU RoHS requirements for all 10 RoHS substances, including the requirement that RoHS substance do not exceed 0.1% by weight in homogeneous materials. Where designed to be soldered at high temperatures, "RoHS" products are suitable for use in specified lead-free processes. TI may reference these types of products as "Pb-Free".

RoHS Exempt: TI defines "RoHS Exempt" to mean products that contain lead but are compliant with EU RoHS pursuant to a specific EU RoHS exemption.

Green: TI defines "Green" to mean the content of Chlorine (Cl) and Bromine (Br) based flame retardants meet JS709B low halogen requirements of <=1000ppm threshold. Antimony trioxide based flame retardants must also meet the <=1000ppm threshold requirement.

(3) MSL, Peak Temp. - The Moisture Sensitivity Level rating according to the JEDEC industry standard classifications, and peak solder temperature.

(4) There may be additional marking, which relates to the logo, the lot trace code information, or the environmental category on the device.

(5) Multiple Device Markings will be inside parentheses. Only one Device Marking contained in parentheses and separated by a "~" will appear on a device. If a line is indented then it is a continuation of the previous line and the two combined represent the entire Device Marking for that device.

(6) Lead finish/Ball material - Orderable Devices may have multiple material finish options. Finish options are separated by a vertical ruled line. Lead finish/Ball material values may wrap to two lines if the finish value exceeds the maximum column width.

Important Information and Disclaimer:The information provided on this page represents TI's knowledge and belief as of the date that it is provided. TI bases its knowledge and belief on information provided by third parties, and makes no representation or warranty as to the accuracy of such information. Efforts are underway to better integrate information from third parties. TI has taken and continues to take reasonable steps to provide representative and accurate information but may not have conducted destructive testing or chemical analysis on incoming materials and chemicals. TI and TI suppliers consider certain information to be proprietary, and thus CAS numbers and other limited information may not be available for release.

In no event shall TI's liability arising out of such information exceed the total purchase price of the TI part(s) at issue in this document sold by TI to Customer on an annual basis.

TAPE AND REEL INFORMATION

QUADRANT ASSIGNMENTS FOR PIN 1 ORIENTATION IN TAPE

*All dimensions are nominal

Device	Package Type	Package Drawing	Pins	SPQ	Reel Diameter (mm)	Reel Width W1 (mm)	A0 (mm)	B0 (mm)	K0 (mm)	P1 (mm)	W (mm)	Pin1 Quadrant
SN75DP129RHHR	VQFN	RHH	36	2500	330.0	16.4	6.3	6.3	1.1	12.0	16.0	Q2
SN75DP129RHHT	VQFN	RHH	36	250	180.0	16.4	6.3	6.3	1.1	12.0	16.0	Q2

TAPE AND REEL BOX DIMENSIONS

*All dimensions are nominal

Device	Package Type	Package Drawing	Pins	SPQ	Length (mm)	Width (mm)	Height (mm)
SN75DP129RHHR	VQFN	RHH	36	2500	367.0	367.0	38.0
SN75DP129RHHT	VQFN	RHH	36	250	210.0	185.0	35.0

GENERIC PACKAGE VIEW

RHH 36

VQFN - 1 mm max height

6 x 6, 0.5 mm pitch

PLASTIC QUAD FLATPACK - NO LEAD

This image is a representation of the package family, actual package may vary.
Refer to the product data sheet for package details.

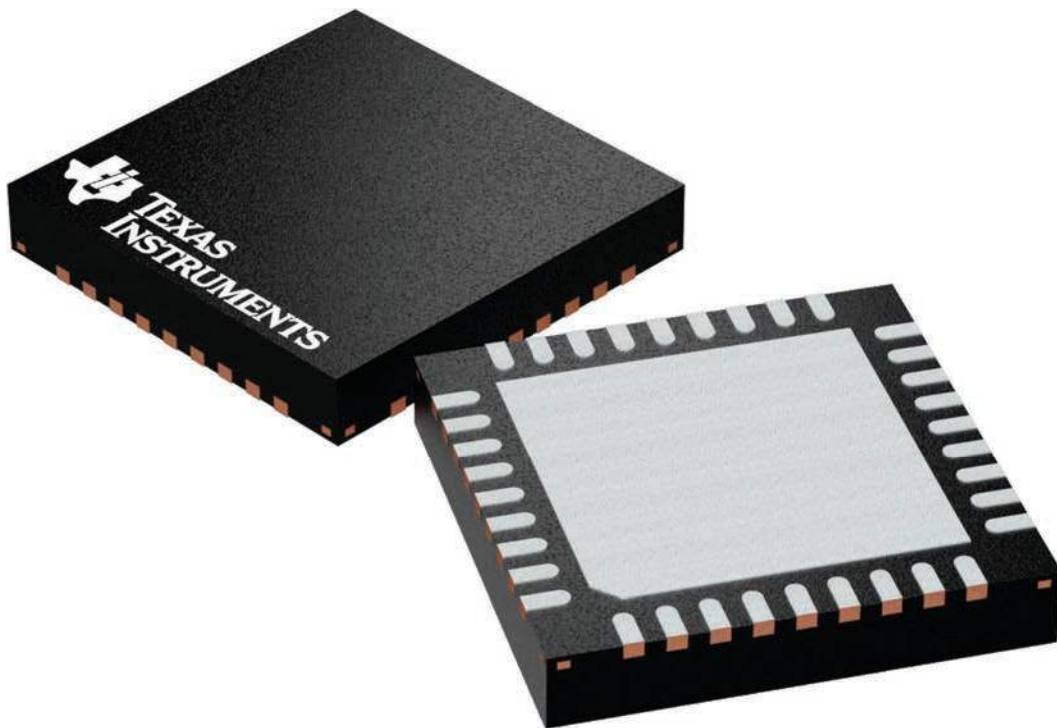

4225440/A

RHH0036B

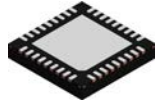

PACKAGE OUTLINE

VQFN - 1 mm max height

PLASTIC QUAD FLATPACK - NO LEAD

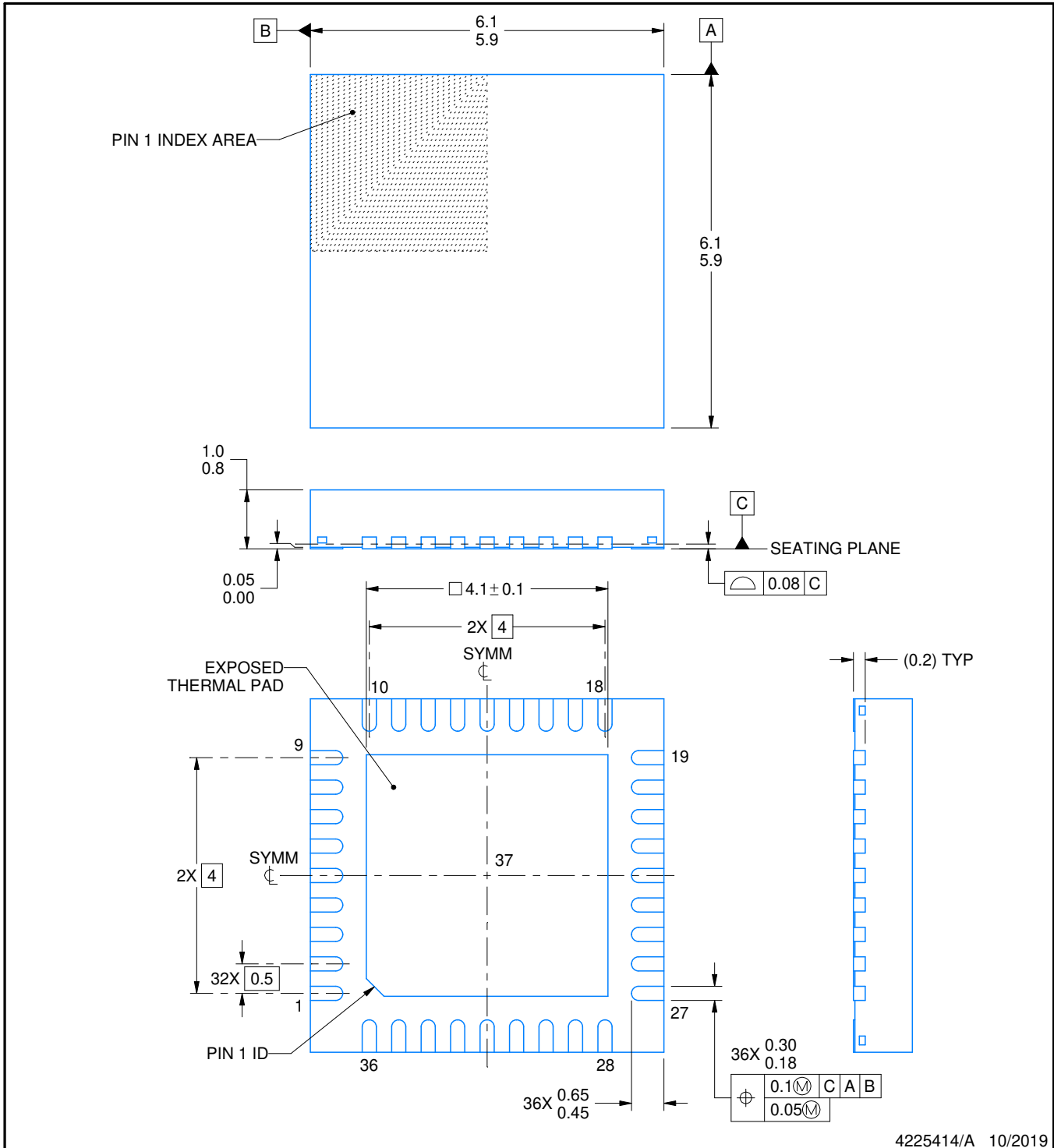

4225414/A 10/2019

NOTES:

1. All linear dimensions are in millimeters. Any dimensions in parenthesis are for reference only. Dimensioning and tolerancing per ASME Y14.5M.
2. This drawing is subject to change without notice.
3. The package thermal pad must be soldered to the printed circuit board for thermal and mechanical performance.

EXAMPLE BOARD LAYOUT

RHH0036B

VQFN - 1 mm max height

PLASTIC QUAD FLATPACK - NO LEAD

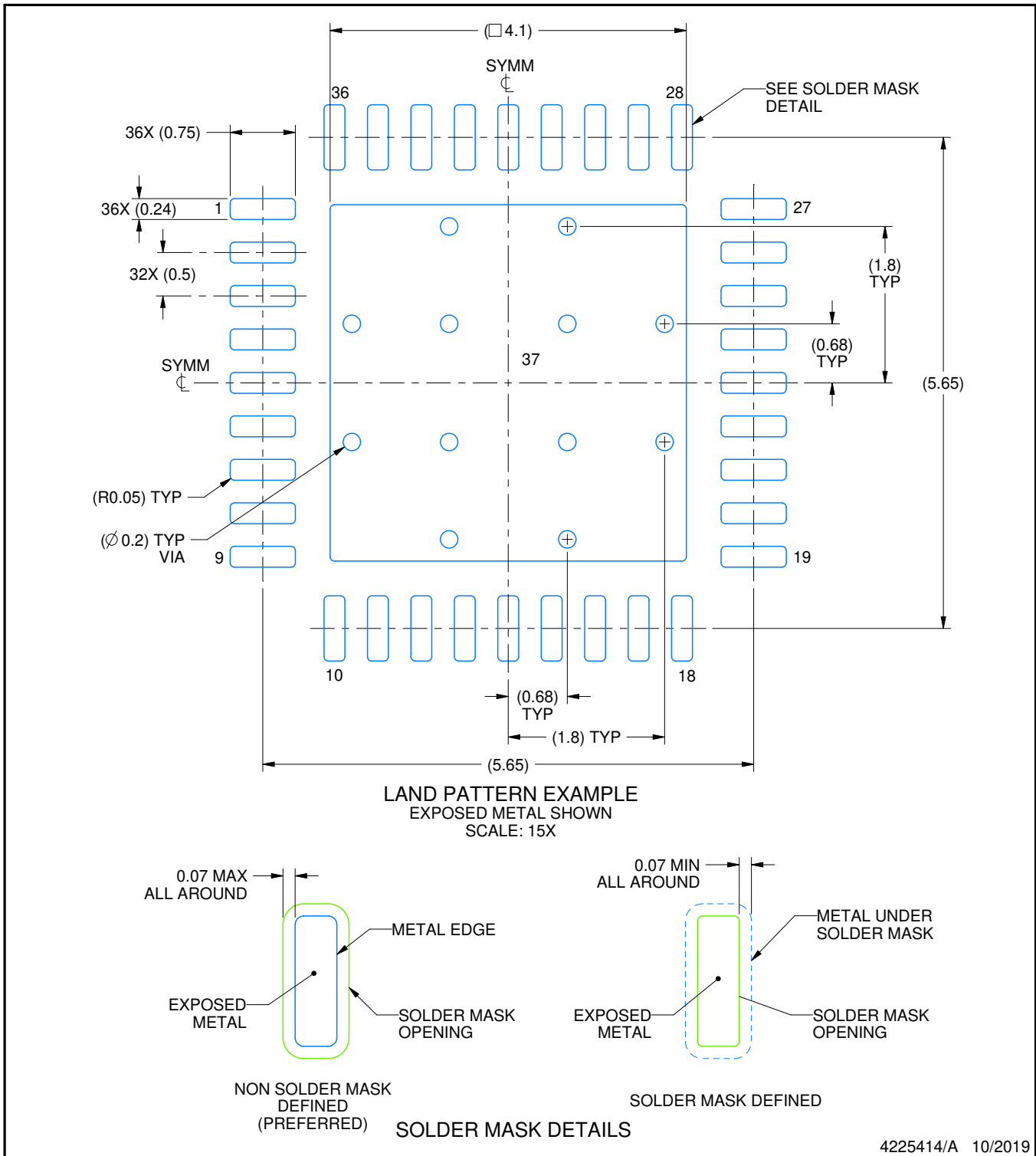

NOTES: (continued)

4. This package is designed to be soldered to a thermal pad on the board. For more information, see Texas Instruments literature number SLUA271 (www.ti.com/lit/sluea271).
5. Vias are optional depending on application, refer to device data sheet. If any vias are implemented, refer to their locations shown on this view. It is recommended that vias under paste be filled, plugged or tented.

EXAMPLE STENCIL DESIGN

RHH0036B

VQFN - 1 mm max height

PLASTIC QUAD FLATPACK - NO LEAD

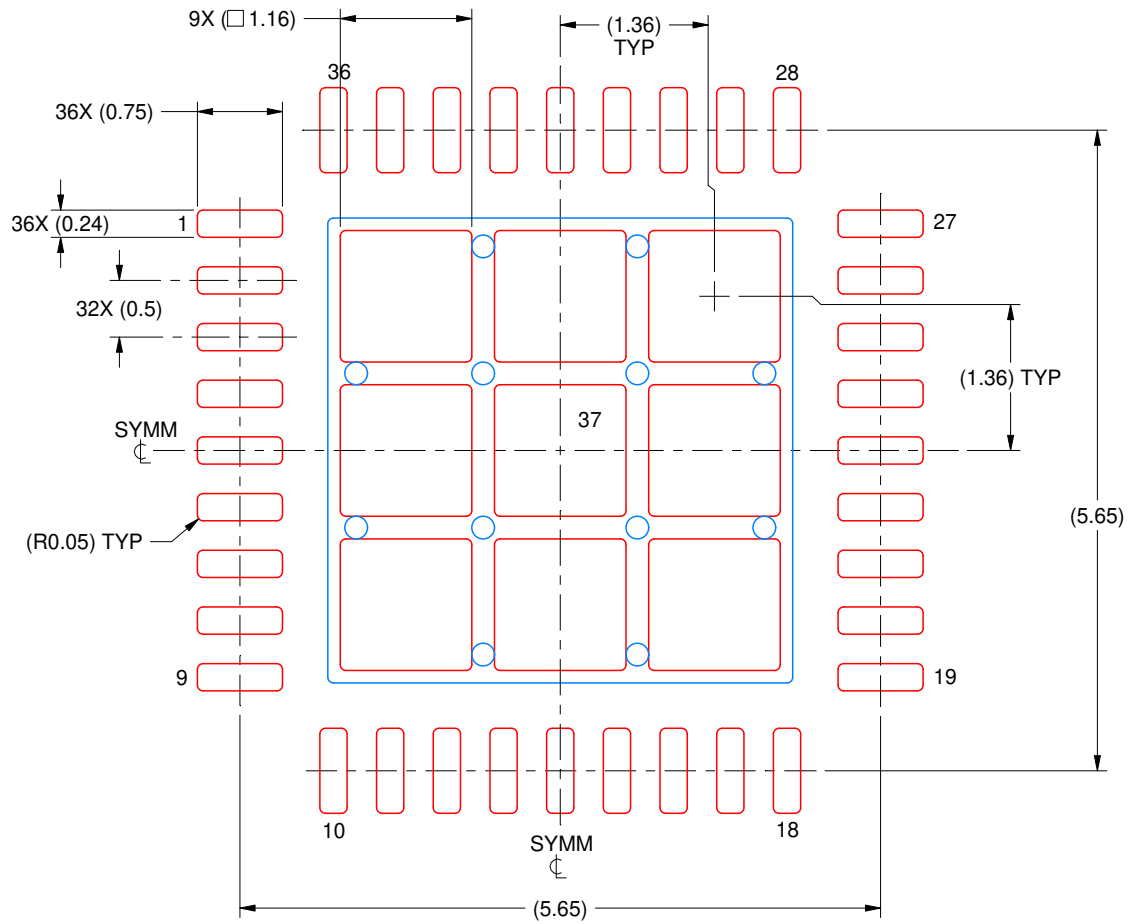

SOLDER PASTE EXAMPLE
BASED ON 0.125 MM THICK STENCIL
SCALE: 15X

EXPOSED PAD 37
72% PRINTED SOLDER COVERAGE BY AREA UNDER PACKAGE

4225414/A 10/2019

NOTES: (continued)

6. Laser cutting apertures with trapezoidal walls and rounded corners may offer better paste release. IPC-7525 may have alternate design recommendations.

IMPORTANT NOTICE AND DISCLAIMER

TI PROVIDES TECHNICAL AND RELIABILITY DATA (INCLUDING DATASHEETS), DESIGN RESOURCES (INCLUDING REFERENCE DESIGNS), APPLICATION OR OTHER DESIGN ADVICE, WEB TOOLS, SAFETY INFORMATION, AND OTHER RESOURCES "AS IS" AND WITH ALL FAULTS, AND DISCLAIMS ALL WARRANTIES, EXPRESS AND IMPLIED, INCLUDING WITHOUT LIMITATION ANY IMPLIED WARRANTIES OF MERCHANTABILITY, FITNESS FOR A PARTICULAR PURPOSE OR NON-INFRINGEMENT OF THIRD PARTY INTELLECTUAL PROPERTY RIGHTS.

These resources are intended for skilled developers designing with TI products. You are solely responsible for (1) selecting the appropriate TI products for your application, (2) designing, validating and testing your application, and (3) ensuring your application meets applicable standards, and any other safety, security, or other requirements. These resources are subject to change without notice. TI grants you permission to use these resources only for development of an application that uses the TI products described in the resource. Other reproduction and display of these resources is prohibited. No license is granted to any other TI intellectual property right or to any third party intellectual property right. TI disclaims responsibility for, and you will fully indemnify TI and its representatives against, any claims, damages, costs, losses, and liabilities arising out of your use of these resources.

TI's products are provided subject to TI's Terms of Sale (www.ti.com/legal/termsofsale.html) or other applicable terms available either on ti.com or provided in conjunction with such TI products. TI's provision of these resources does not expand or otherwise alter TI's applicable warranties or warranty disclaimers for TI products.

Mailing Address: Texas Instruments, Post Office Box 655303, Dallas, Texas 75265
Copyright © 2020, Texas Instruments Incorporated